

The reproduction, distribution and utilization of this document as well as the communication of its contents to others without express authorization is prohibited. Offenders will be held liable for the payment of damages. All rights reserved in the event of the grant of a patent, utility model or design. Copyright reserved.

1	2	3	4
REVISIONS			
REV.	DESCRIPTION	DATE	BY
-	See 205.19.00.TS	-	-

FINAL DRAWING

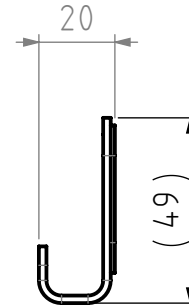
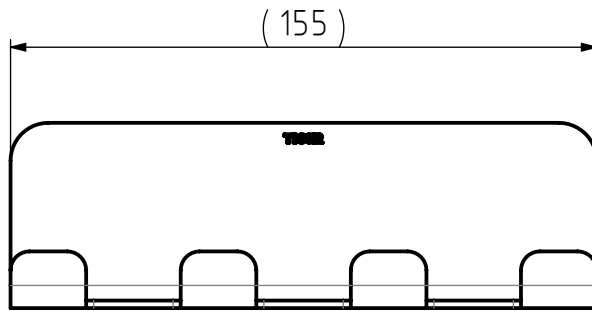
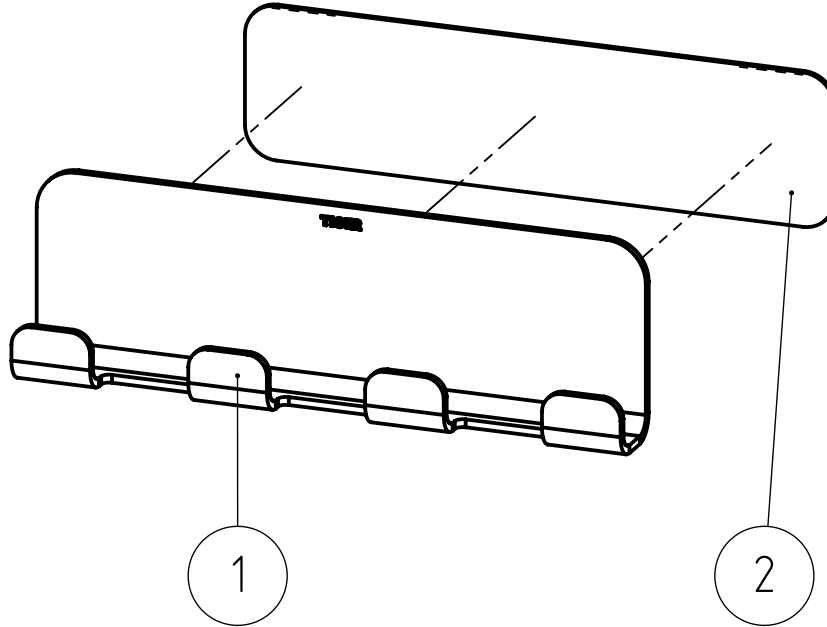

2	Tape Multi hook	1	205.19.02	3M Tape VHB GPH110 1.10mm	
1	Multi hook	1	205.19.01	Stainless steel AISI 430	Powder coated, texture VDI 3400 ref.30 - RAL 9005 (Jet black)
NR.	DESCRIPTION	QTY.	DRAW.NR.	MATERIAL	TREATMENT

GENERAL DIMENSION UNLESS OTHERWISE STATED ACCORDING TO DIN 7168								DESCRIPTION:	
CLASS	NOMINAL MEASUREMENTS (mm)							Multihook	
	0.5 UNTIL 3	3 UNTIL 6	6 UNTIL 30	30 UNTIL 120	120 UNTIL 400	400 UNTIL 1000	1000 UNTIL 2000		
M (MIDDLE)	±0.1	±0.1	±0.2	±0.3	±0.5	±0.8	±1.2	±2	

PROJECTION: 	GENERAL ANGLE: ±0,5°	VERSION NAME: black	ARTICLE NR. (packed product): 1314730746 (for packaging information see GDS)
-----------------	-------------------------	------------------------	--

DRAWN BY: MS	GENERAL ROUGHNESS: 0,8	PROJECT: 205-Colar	TIGER Tiger Products b.v. Winde 3, PO box 11 5660 AA Geldrop The Netherlands
CHECKED BY:		DRAWING NR: 205.19.00.TB	
DATE: 6-4-2016	UNITS: mm		
STATUS: Production	SCALE: 1:2		
PRINT DATE: 14-4-2026	FORMAT: A4		
INT.REV.NR.: 02	SHEET: 3/3		