

FINAL DRAWING

REVISIONS				
REV.	DESCRIPTION	DATE	BY	APPROVED
-	See 205.26.00.TS	-	-	-

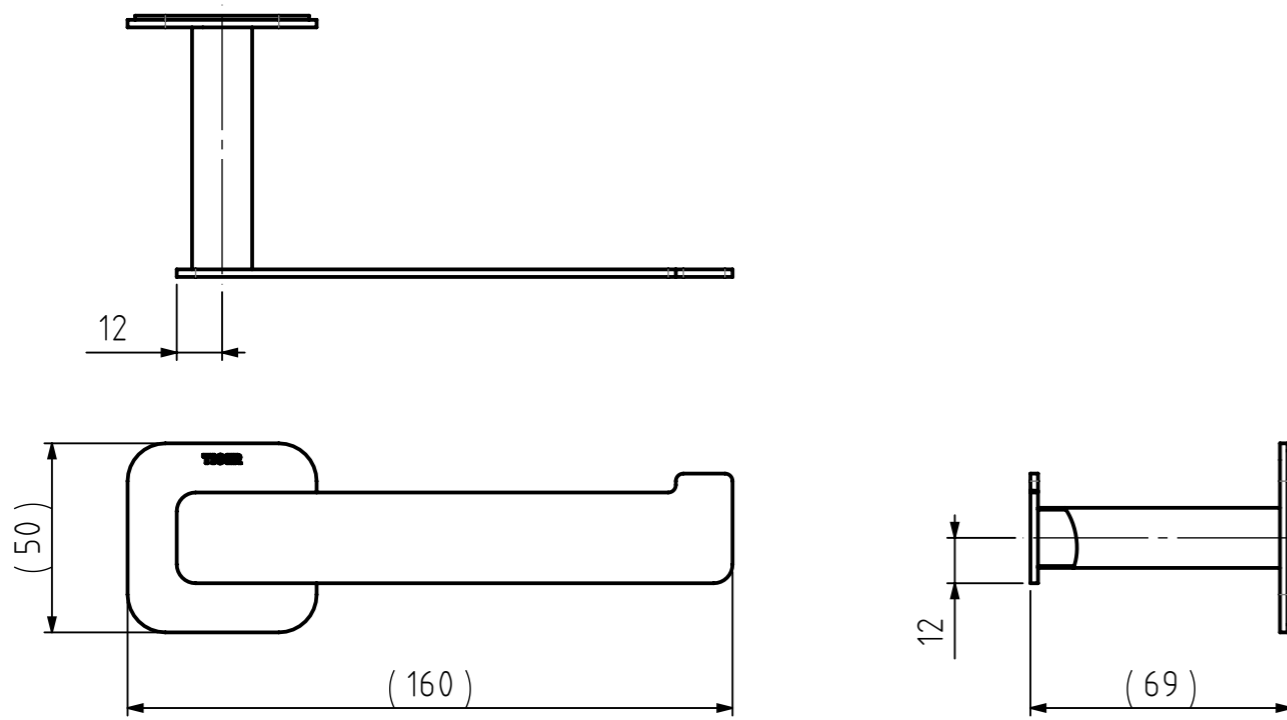
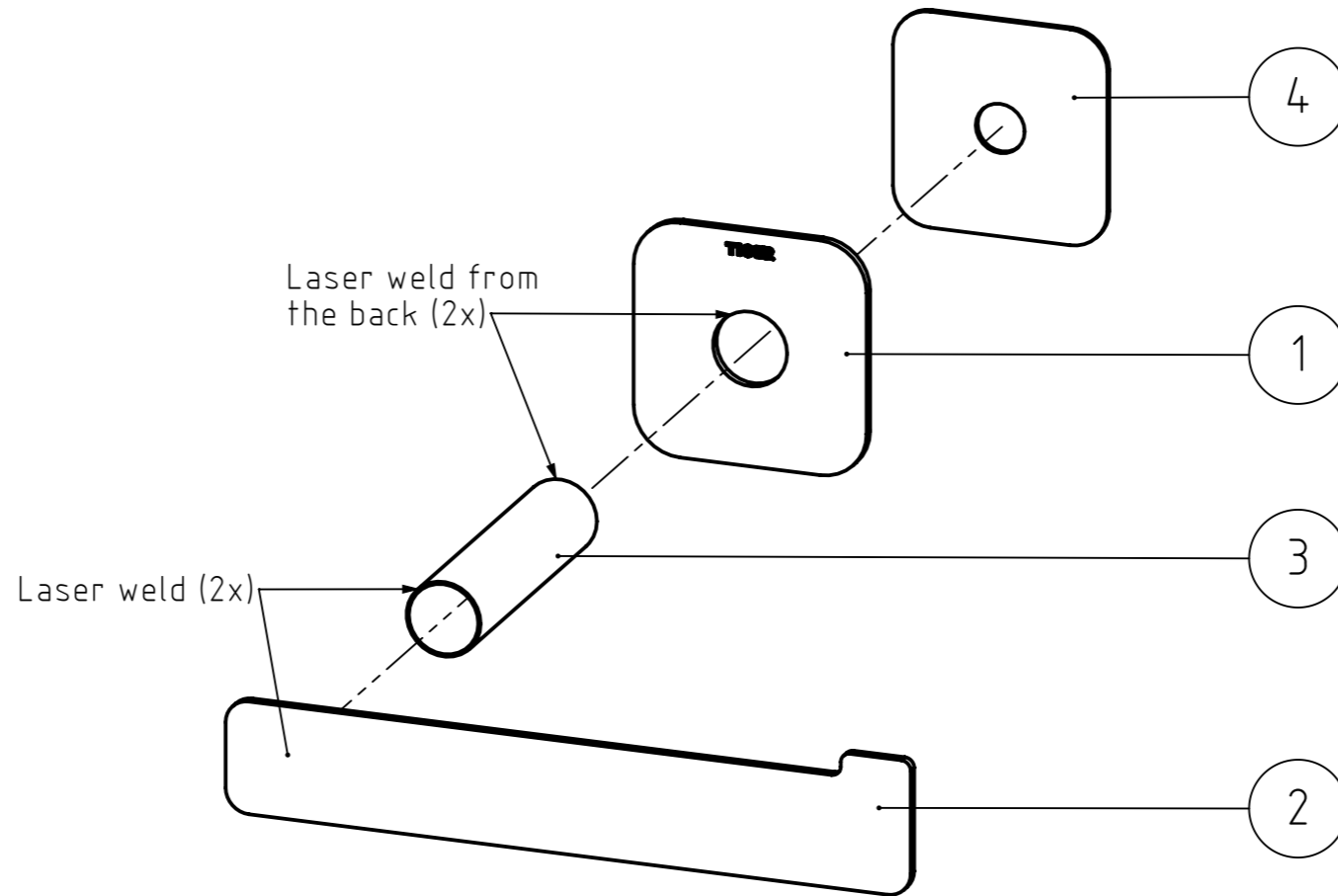

Remarks:
- Welds may not be visible from the front

NR.	DESCRIPTION	QTY.	DRAW.NR.	MATERIAL	TREATMENT
4	Tape pad big	1	205.04.08	3M Tape VHB GPH110 1.10mm	-
3	Tube	1	205.26.03	Stainless steel AISI 430	Powder coated, texture VDI 3400 ref.30 - RAL 9005 (Jet black)
2	Toilet roll holder rigid	1	205.26.01	Stainless steel AISI 430	Powder coated, texture VDI 3400 ref.30 - RAL 9005 (Jet black)
1	Wall plate 2 (top logo)	1	205.09.04	Stainless steel AISI 430	Powder coated, texture VDI 3400 ref.30 - RAL 9005 (Jet black)

GENERAL DIMENSION UNLESS OTHERWISE STATED ACCORDING TO DIN 7168							DESCRIPTION:	
CLASS	NOMINAL MEASUREMENTS (mm)						Toilet roll holder rigid	
	0.5 UNTIL 3	3 UNTIL 6	6 UNTIL 30	30 UNTIL 120	120 UNTIL 400	400 UNTIL 1000		
M (MIDDLE)	±0.1	±0.1	±0.2	±0.3	±0.5	±0.8	±1.2	±2
PROJECTION:	GENERAL ANGLE: ±0,5°		VERSION NAME: black		ARTICLE NR. (packed product): 1313930746			(for packaging information see GDS)
DRAWN BY:	MS		GENERAL ROUGHNESS: 0,8		PROJECT: 205-Colar			Tiger Products b.v. Winde 3, PO box 11 5660 AA Geldrop The Netherlands
CHECKED BY:					DRAWING NR: 205.26.00.TB			
DATE:	23-5-2016		UNITS: mm					
STATUS:	Production		SCALE: 1:2					
PRINT DATE:	14-4-2026		FORMAT: A3					
INT.REV.NR.:	01		SHEET: 3/3					

The reproduction, distribution and utilization of this document as well as the communication of its contents to others without express authorization is prohibited. Offenders will be held liable for the payment of damages. All rights reserved in the event of the grant of a patent, utility model or design. Copyright reserved.