

FINAL DRAWING

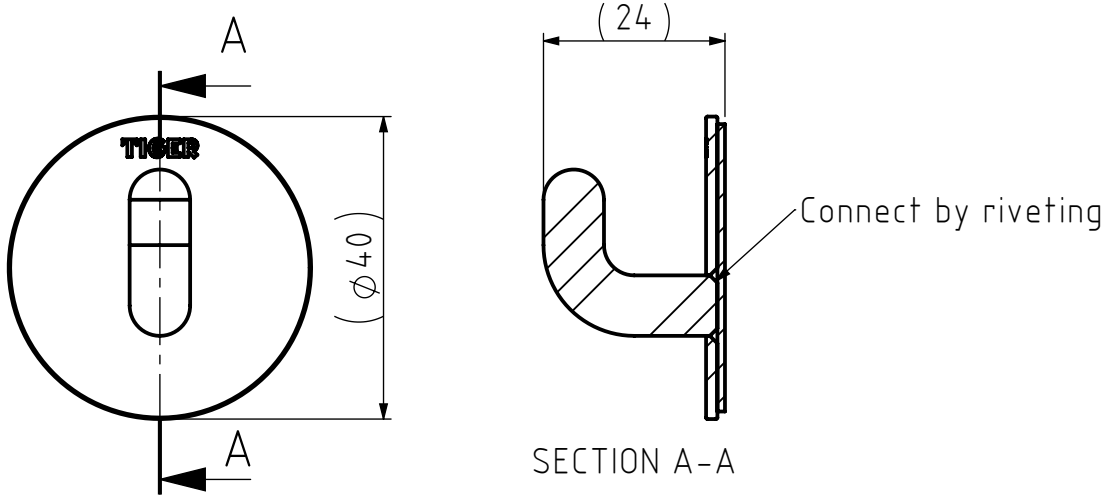
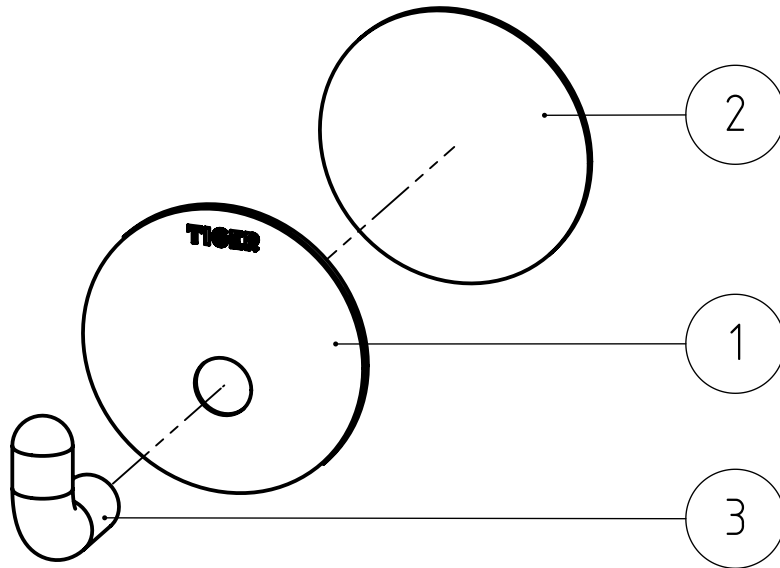

Remarks:
- Make the back of the riveting as flat as possible.

NR.	DESCRIPTION	QTY.	DRAW.NR.	MATERIAL	TREATMENT
3	Hook Pinky	1	178.06.02	Stainless steel 430	Powder coated - RAL 9003 (Signal white), Matt
2	ADHESIVE FOAM	1	142.01.04	3M / NO.1600 / FOAM TAPE 1.0 MM	-
1	Wall plate	1	225.01.01	Stainless steel 430	Powder coated - RAL 9003 (Signal white), Matt

GENERAL DIMENSION UNLESS OTHERWISE STATED ACCORDING TO DIN 7168								DESCRIPTION:		
CLASS	NOMINAL MEASUREMENTS (mm)								Pinky round	
	0.5 UNTIL 3	3 UNTIL 6	6 UNTIL 30	30 UNTIL 120	120 UNTIL 400	400 UNTIL 1000	1000 UNTIL 2000	2000 UNTIL 4000		
M (MIDDLE)	±0.1	±0.1	±0.2	±0.3	±0.5	±0.8	±1.2	±2	DESCRIPTION:	
PROJECTION:	GENERAL ANGLE:		EAN:			VERSION NAME:		ARTICLE NR.:		
	±0,5°		4008911117042			white matt		11175.3.01.42		
DRAWN BY:	MS		GENERAL ROUGHNESS:			PROJECT:		 Tiger Products b.v. Winde 3, PO box 11 5660 AA Geldrop The Netherlands		
CHECKED BY:	FVP		0,8			225-hooks 2016				
DATE:	16-9-2016		UNITS:			DRAWING NR.:				
STATUS:	Production		mm			225.01.00.TWM				
PRINT DATE:	8-4-2026		SCALE:							
INT.REV.NR.:	00		FORMAT:							
			SHEET:							
			2/2							

The reproduction, distribution and utilization of this document as well as the communication of its contents to others without express authorization is prohibited. Offenders will be held liable for the payment of damages. All rights reserved in the event of the grant of a patent, utility model or design. Copyright reserved.