

FINAL DRAWING

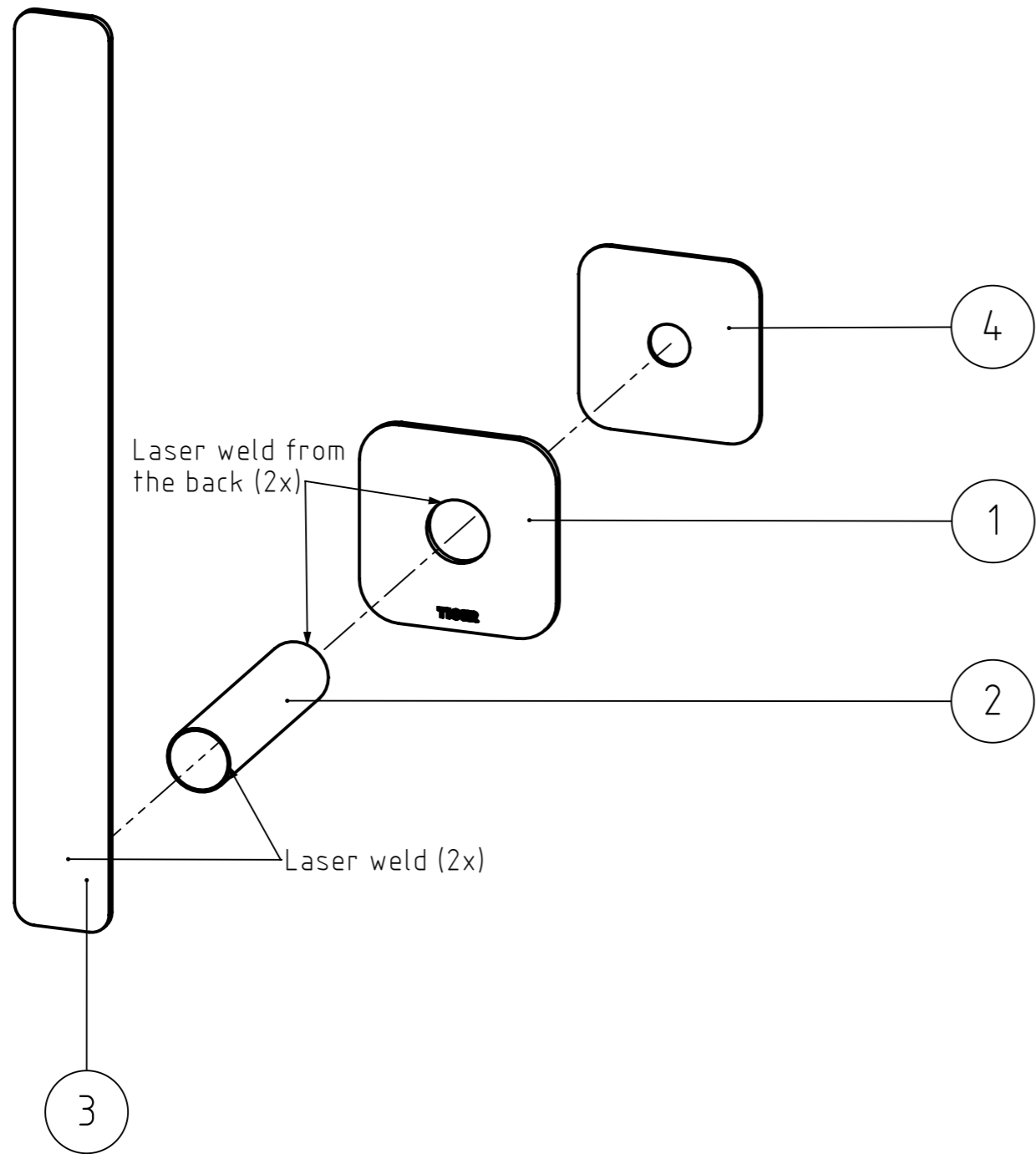

REVISIONS				
REV.	DESCRIPTION	DATE	BY	APPROVED
-	See 205.28.00.TS	-	-	-

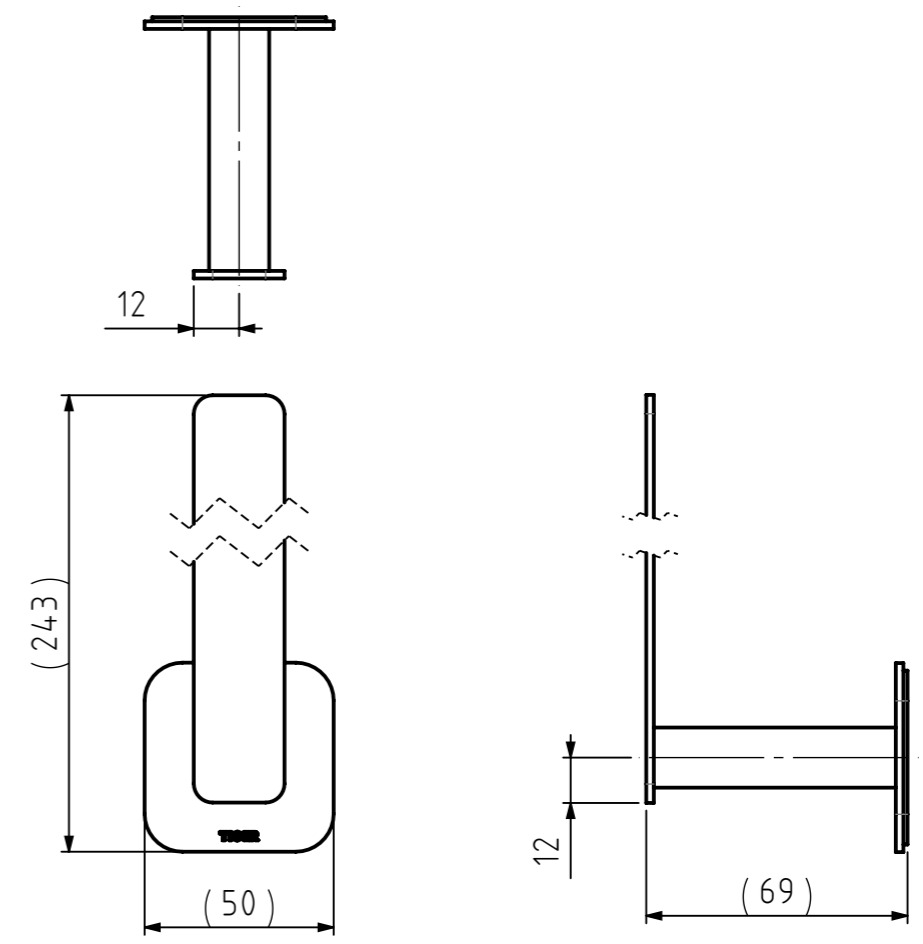

Remarks:
- Welds may not be visible from the front

NR.	DESCRIPTION	QTY.	DRAW.NR.	MATERIAL	TREATMENT
4	Tape pad big	1	205.04.08	3M Tape VHB GPH110 1.10mm	-
3	Spare roll holder	1	205.28.01	Stainless steel 304	Polished - High gloss
2	Tube	1	205.26.03	Stainless steel 304	Polished - High gloss
1	Wall plate 2 (bottom logo)	1	205.09.04	Stainless steel 304	Polished - High gloss

GENERAL DIMENSION UNLESS OTHERWISE STATED ACCORDING TO DIN 7168		DESCRIPTION:						
CLASS	NOMINAL MEASUREMENTS (mm)						Spare toilet roll holder	
	0.5 UNTIL 3	3 UNTIL 6	6 UNTIL 30	30 UNTIL 120	120 UNTIL 400	400 UNTIL 2000		
M (MIDDLE)	±0.1	±0.1	±0.2	±0.3	±0.5	±0.8	±1.2	±2
PROJECTION:	GENERAL ANGLE: ±0,5°		VERSION NAME: chrome		ARTICLE NR. (packed product): 1312930346 (for packaging information see GDS)			
DRAWN BY:	MS		GENERAL ROUGHNESS: 0,8		PROJECT: 205-Colar			
CHECKED BY:					DRAWING NR: 205.28.00.TC			
DATE:	23-5-2016		UNITS: mm		Tiger Products b.v. Winde 3, PO box 11 5660 AA Geldrop The Netherlands			
STATUS:	Production		SCALE: 1:2					
PRINT DATE:	14-4-2026		FORMAT: A3					
INT.REV.NR.:	01		SHEET: 2/3					

The reproduction, distribution and utilization of this document as well as the communication of its contents to others without express authorization is prohibited. Offenders will be held liable for the payment of damages. All rights reserved in the event of the grant of a patent, utility model or design. Copyright reserved.