

# FINAL DRAWING

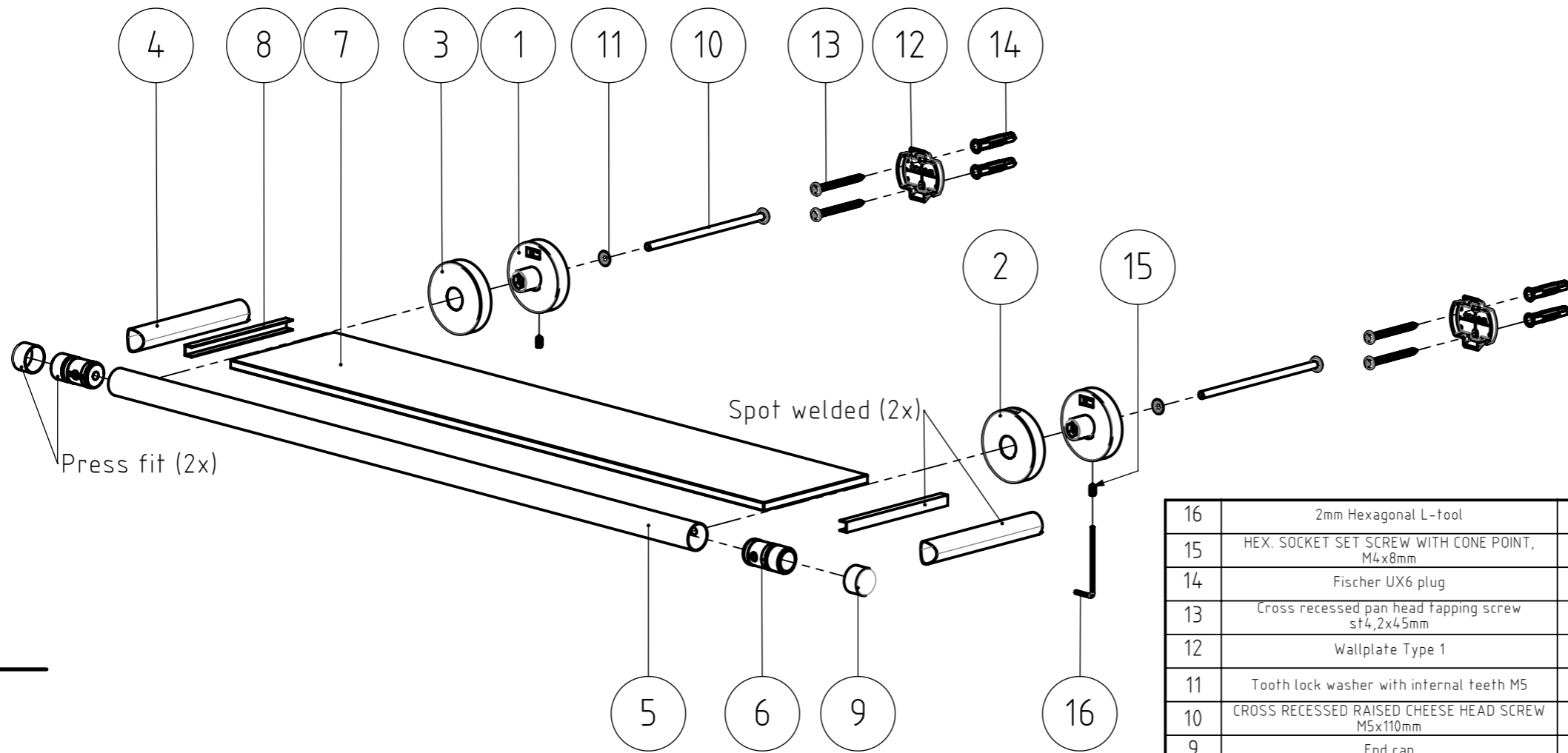

NR.	DESCRIPTION	QTY.	DRAW.NR.	MATERIAL	TREATMENT
16	2mm Hexagonal L-tool	1	DIN.911	Tool steel	-
15	HEX. SOCKET SET SCREW WITH CONE POINT, M4x8mm	2	DIN.0914	Stainless steel A2	-
14	Fischer UX6 plug	4	FIX.0028	-	-
13	Cross recessed pan head tapping screw st4,2x4,5mm	4	DIN.7981 CZ	Stainless steel A2	-
12	Wallplate Type 1	2	226.03.02	Stainless steel AISI 304	Sand blasted
11	Tooth lock washer with internal teeth M5	2	DIN.6797	Stainless steel A2	-
10	CROSS RECESSED RAISED CHEESE HEAD SCREW M5x110mm	2	ISO.7045	Stainless steel A2	-
9	End cap	2	040.03.07	Stainless steel AISI 304	Brushed
8	U-profile	2	040.03.06	Stainless steel AISI 304	Brushed
7	Shelf	1	040.03.04	Tempered glass	Frosted
6	Tube connector A	2	040.03.03	Zamac3	Chromium Plated
5	Front bar	1	040.03.02	Stainless steel AISI 304	Brushed
4	Shelf support tube	2	040.03.01	Stainless steel AISI 304	Brushed
3	Cover (no logo)	1	040.01.03	Stainless steel AISI 304	Brushed
2	Cover	1	040.01.03	Stainless steel AISI 304	Brushed
1	Wall support	2	040.01.01	Zamac3	Chromium Plated

GENERAL DIMENSION UNLESS OTHERWISE STATED ACCORDING TO DIN 7168		DESCRIPTION:	
NOMINAL MEASUREMENTS (mm)		Shelf	
CLASS	0.5 UNTIL 3 3 UNTIL 6 6 UNTIL 30 30 UNTIL 120 120 UNTIL 400 400 UNTIL 1000 1000 UNTIL 2000 2000 UNTIL 4000		
M (MIDDLE)	±0.1 ±0.1 ±0.2 ±0.3 ±0.5 ±0.8 ±1.2 ±2	VERSION NAME: stainless steel	
PROJECTION:	GENERAL ANGLE: ±0,5°	EAN: 4008913084403	ARTICLE NR.: 3084.3.09.46
DRAWN BY: FVP	GENERAL ROUGHNESS: 0,8	PROJECT: 040-Boston	
CHECKED BY:		DRAWING NR: 040.03.00.TS	
DATE: 24-7-2006	UNITS: mm	<b>TIGER</b> Tiger Nederland b.v. Winde 3, PO box 11 5660 AA Geldrop The Netherlands	
STATUS: Production	SCALE: 1:4		
PRINT DATE: 3-10-2024	FORMAT: A3		
INT.REV.NR.: 01	SHEET: 2/2		

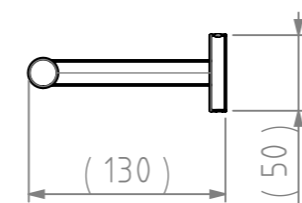
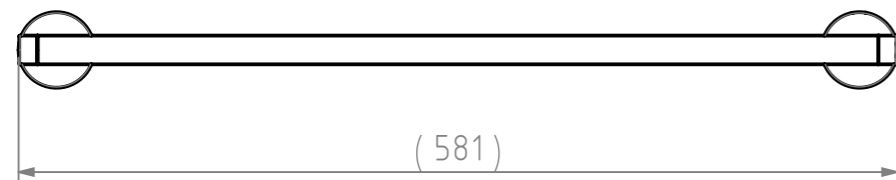

The reproduction, distribution and utilization of this document as well as the communication of its contents to others without express authorization is prohibited. Offenders will be held liable for the payment of damages. All rights reserved in the event of the grant of a patent, utility model or design. Copyright reserved.