

FINAL DRAWING

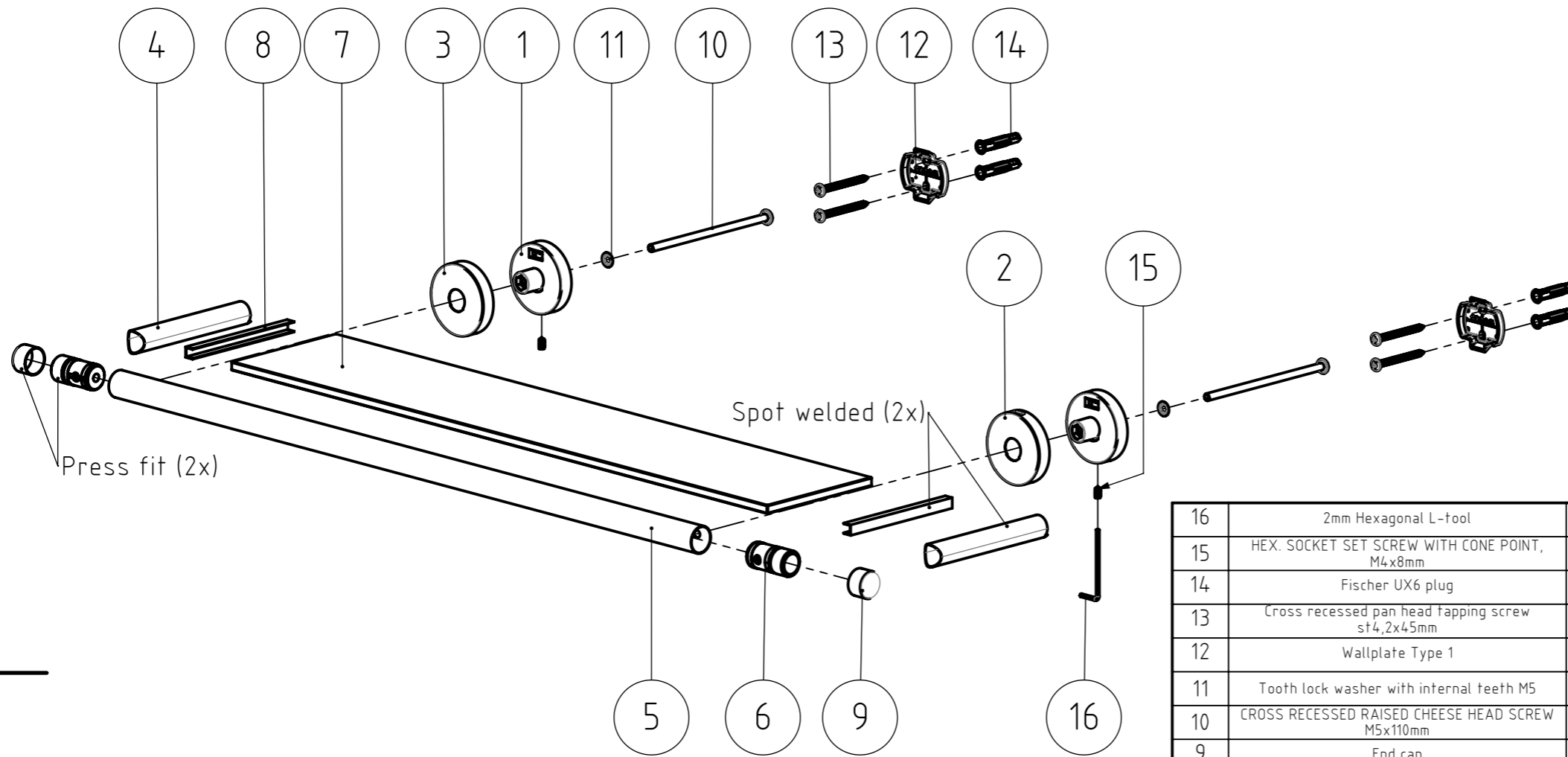

NR.	DESCRIPTION	QTY.	DRAW.NR.	MATERIAL	TREATMENT
16	2mm Hexagonal L-tool	1	DIN.911	Tool steel	-
15	HEX. SOCKET SET SCREW WITH CONE POINT, M4x8mm	2	DIN.0914	Stainless steel A2	-
14	Fischer UX6 plug	4	FIX.0028	-	-
13	Cross recessed pan head tapping screw st4,2x4,5mm	4	DIN.7981 CZ	Stainless steel A2	-
12	Wallplate Type 1	2	226.03.02	Stainless steel AISI 304	Sand blasted
11	Tooth lock washer with internal teeth M5	2	DIN.6797	Stainless steel A2	-
10	CROSS RECESSED RAISED CHEESE HEAD SCREW M5x110mm	2	ISO.7045	Stainless steel A2	-
9	End cap	2	040.03.07	Stainless steel AISI 304	Polished - High gloss
8	U-profile	2	040.03.06	Stainless steel AISI 304	Polished - High gloss
7	Shelf	1	040.03.04	Tempered glass	Frosted
6	Tube connector A	2	040.03.03	Zamac3	Chromium Plated
5	Front bar	1	040.03.02	Stainless steel AISI 304	Polished - High gloss
4	Shelf support tube	2	040.03.01	Stainless steel AISI 304	Polished - High gloss
3	Cover (no logo)	1	040.01.03	Stainless steel AISI 304	Polished - High gloss
2	Cover	1	040.01.03	Stainless steel AISI 304	Polished - High gloss
1	Wall support	2	040.01.01	Zamac3	Chromium Plated

GENERAL DIMENSION UNLESS OTHERWISE STATED ACCORDING TO DIN 7168							DESCRIPTION:		
CLASS	NOMINAL MEASUREMENTS (mm)						Shelf		
	0.5 UNTIL 3	3 UNTIL 6	6 UNTIL 30	30 UNTIL 120	120 UNTIL 400	400 UNTIL 1000			1000 UNTIL 2000
M (MIDDLE)	±0.1	±0.1	±0.2	±0.3	±0.5	±0.8	±1.2	±2	
PROJECTION:	GENERAL ANGLE: ±0,5°			EAN: 4008913084410				VERSION NAME: chrome	ARTICLE NR.: 3084.3.03.46
DRAWN BY:	FVP			GENERAL ROUGHNESS: 0,8		PROJECT: 040-Boston		TIGER Tiger Nederland b.v. Winde 3, PO box 11 5660 AA Geldrop The Netherlands	
CHECKED BY:						DRAWING NR: 040.03.00.TC			
DATE:	24-7-2006			UNITS: mm					
STATUS:	Production			SCALE: 1:4					
PRINT DATE:	3-10-2024			FORMAT: A3					
INT.REV.NR.:	01			SHEET: 1/2					

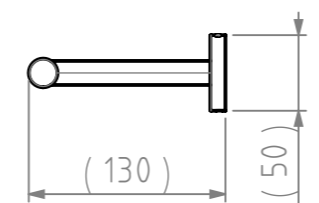
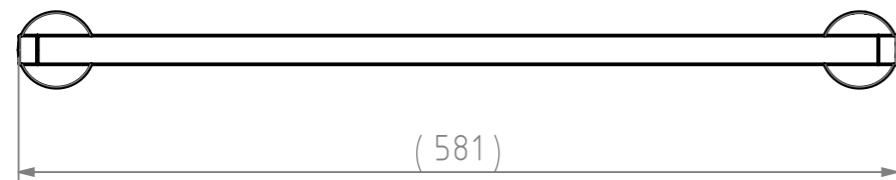

The reproduction, distribution and utilization of this document as well as the communication of its contents to others without express authorization is prohibited. Offenders will be held liable for the payment of damages. All rights reserved in the event of the grant of a patent, utility model or design. Copyright reserved.