

FINAL DRAWING

REVISIONS				
REV.	DESCRIPTION	DATE	BY	APPROVED
1	- 040.01.02 Wall bracket 2 replaced by 226.01.01 Wallplate Type 1. - Screws, plugs and L-tool added to assembly drawing. - Black version created.	10-10-2017	MS	WW

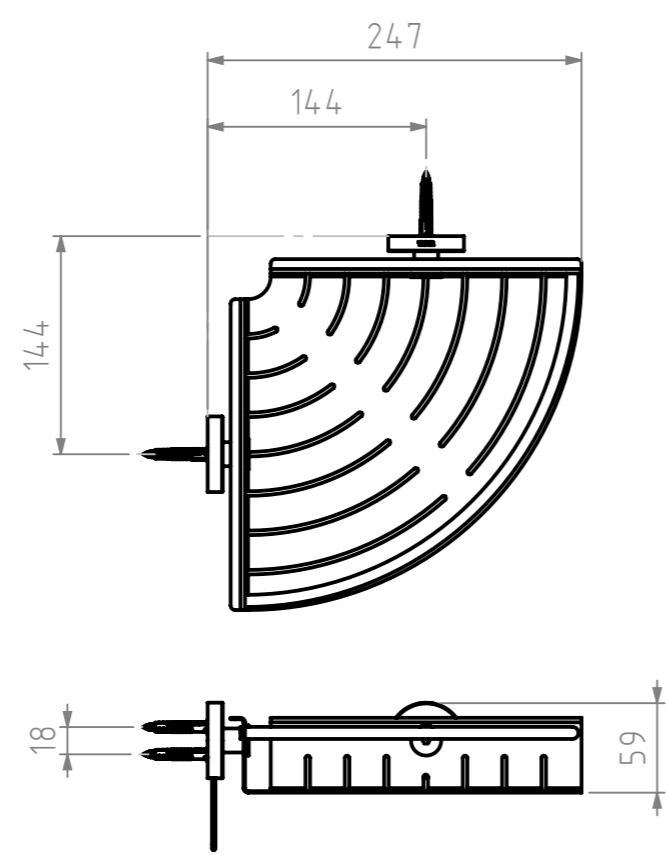
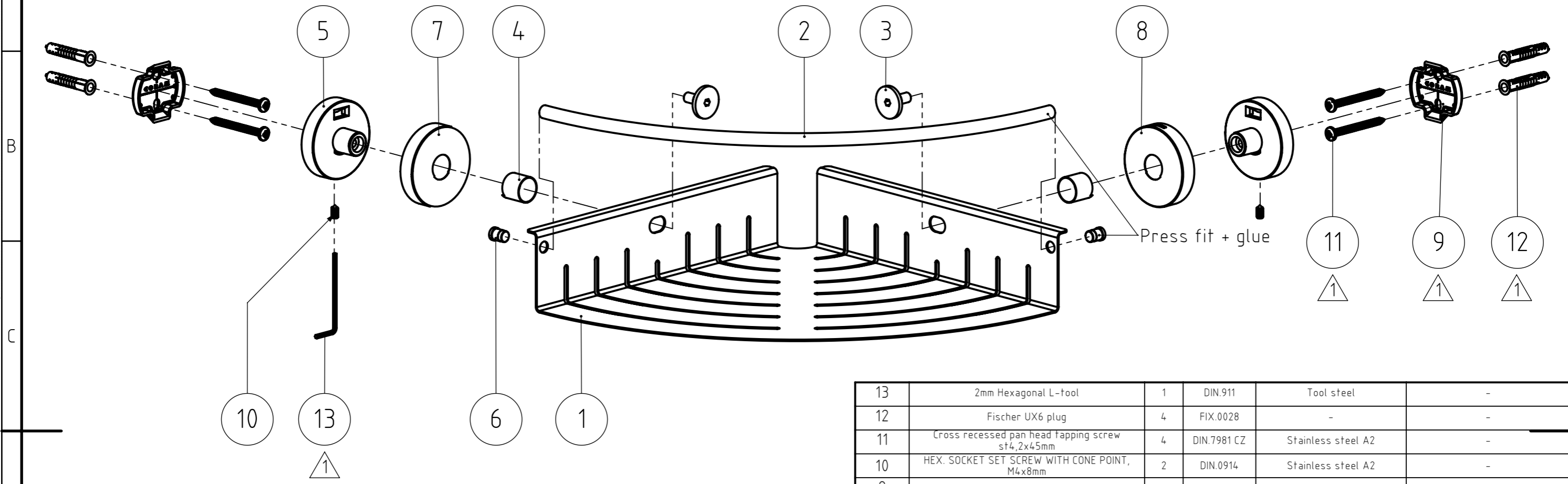

NR.	DESCRIPTION	Q.TY.	DRAW.NR.	MATERIAL	TREATMENT
13	2mm Hexagonal L-tool	1	DIN.911	Tool steel	-
12	Fischer UX6 plug	4	FIX.0028	-	-
11	Cross recessed pan head tapping screw s14,2x45mm	4	DIN.7981 CZ	Stainless steel A2	-
10	HEX. SOCKET SET SCREW WITH CONE POINT, M4x8mm	2	DIN.0914	Stainless steel A2	-
9	Wallplate Type 1	2	226.03.02	Stainless steel AISI 304	Sand blasted
8	Cover	1	040.01.03	Stainless steel AISI 304	Brushed
7	Cover (no logo)	1	040.01.03	Stainless steel AISI 304	Brushed
6	Plug	2	169.02.03	Stainless steel AISI 304	-
5	Wall support	2	169.01.05	Zamac3	Chromium Plated
4	Small cover	2	169.01.04	Stainless steel AISI 304	Brushed
3	Stop	2	169.01.03	Stainless steel AISI 304	Brushed
2	Round bar	1	169.01.02	Stainless steel AISI 304	Brushed
1	Sheet metal	1	169.01.01	Stainless steel AISI 304	Brushed

GENERAL DIMENSION UNLESS OTHERWISE STATED ACCORDING TO DIN 7168		DESCRIPTION:	
NOMINAL MEASUREMENTS (mm)		Corner basket	
CLASS	0.5 UNTIL 3 ±0.1	3 UNTIL 6 ±0.2	6 UNTIL 30 ±0.3
	30 UNTIL 120 ±0.5	120 UNTIL 400 ±0.8	400 UNTIL 1000 ±1.2
	1000 UNTIL 2000 ±2	2000 UNTIL 4000 ±2	
M (MIDDLE)	±0.1 ±0.2 ±0.3 ±0.5 ±0.8 ±1.2 ±2		
PROJECTION:	GENERAL ANGLE: ±0,5°	EAN: 4008913047415	VERSION NAME: stainless steel
DRAWN BY: MS	GENERAL ROUGHNESS: 0,8	PROJECT: 169-Boston corner basket	ARTICLE NR.: 3047.3.09.46
CHECKED BY:	DATE: 6-6-2011	UNITS: mm	TIGER Tiger Products b.v. Winde 3, PO box 11 5660 AA Geldrop The Netherlands
STATUS: Production	SCALE: 1:5	DRAWING NR.: 169.01.00.TS	
PRINT DATE: 9-7-2025	FORMAT: A3		
INT.REV.NR.: 03	SHEET: 1/3		

The reproduction, distribution and utilization of this document as well as the communication of its contents to others without express authorization is prohibited. Offenders will be held liable for the payment of damages. All rights reserved in the event of the grant of a patent, utility model or design. Copyright reserved.