

FINAL DRAWING

REVISIONS				
REV.	DESCRIPTION	DATE	BY	APPROVED
1	- Material of 205.04.02 Connector changed to Zamac3. - Measurements changed.	21-6-2016	MS	WW
2	Construction changed, 205.24.03 Hinge tube, 205.24.04 Hinge end piece and DIN.928 Square weld nut are new parts.	12-7-2016	MS	WW
3	Shape of 205.25.02 Bush has changed	15-9-2016	MS	WW
4	Width of 205.24.02 Arm changed.	4-10-2016	MS	WW
5	Production method and material of 205.01.02 Connector have been changed at the makers request, from Aluminium CNC milling to Zamac3 casting.	26-6-2018	MS	FvP
6	Black version added.	28-7-2021	MS	FvP
7	Changed construction	23-10-2024		

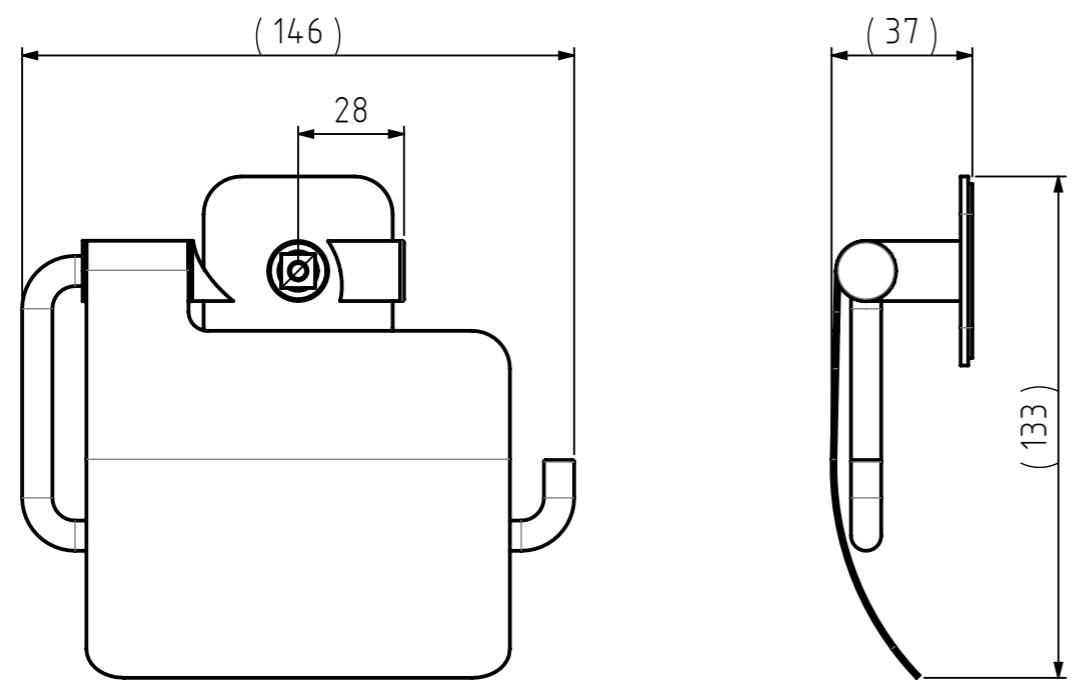
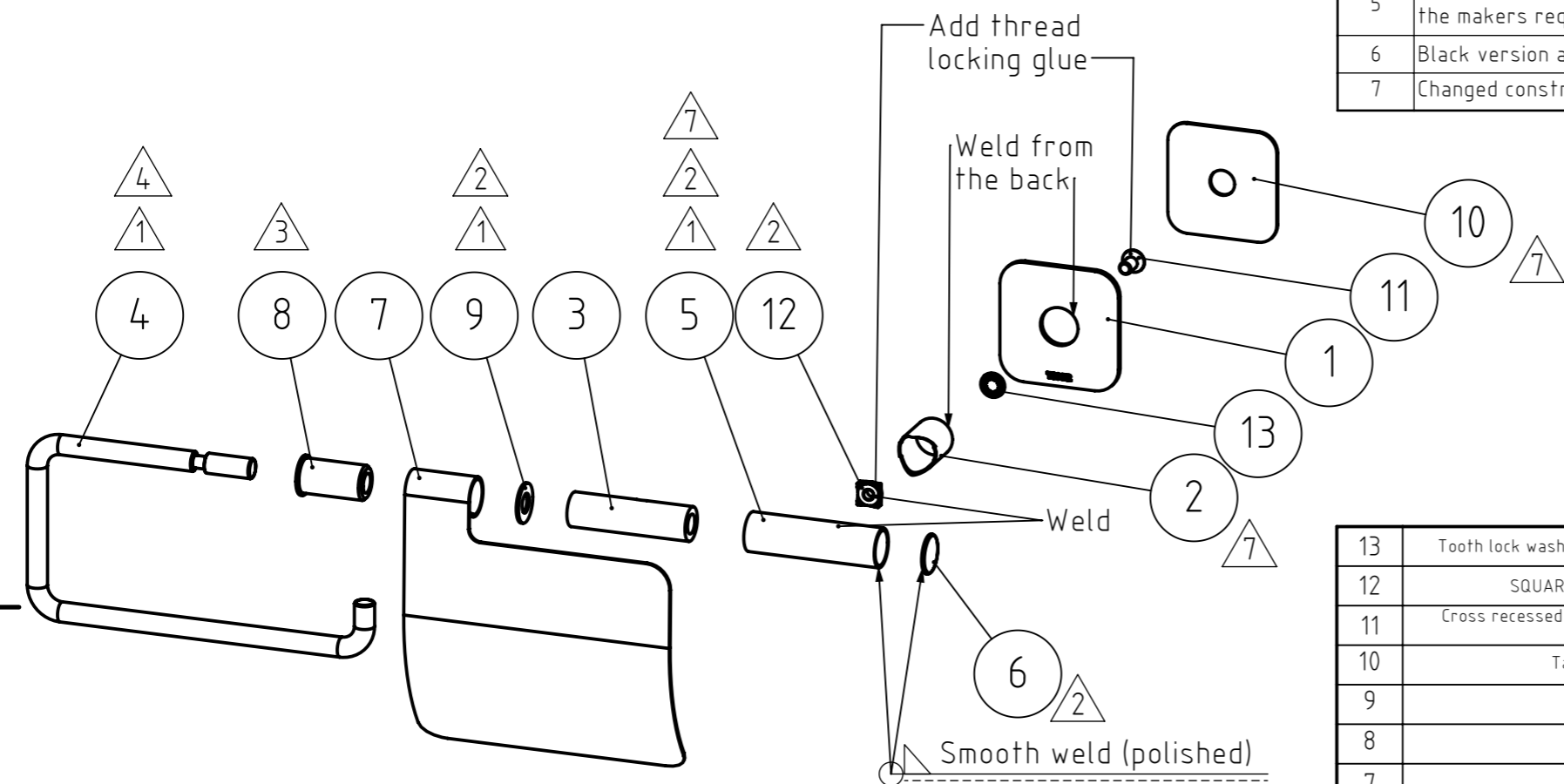

NR.	DESCRIPTION	QTY.	DRAW.NR.	MATERIAL	TREATMENT
13	Tooth lock washer with internal teeth M5	1	DIN.6797	Stainelss steel A2	-
12	SQUARE WELD NUT, M5	1	DIN.928	STAINLESS STEEL	-
11	Cross recessed countersunk head screw M5x10mm	1	ISO 7046	STAINLESS STEEL A2	-
10	Tape pad big	1	205.04.08	3M Tape VHB GPH110 1.10mm	-
9	Ring	1	205.25.03	PA 6 - Black RAL 9005, semi gloss	Technical Smooth
8	Bush	1	205.25.02	PA 6 - Black RAL 9005, semi gloss	Technical Smooth
7	Lid	1	205.25.01	Stainless steel 304	Brushed
6	Hinge end piece	1	205.24.04	Stainless steel 304	Brushed
5	Hinge tube	1	205.24.03	Stainless steel 304	Brushed
4	Arm	1	205.24.02	Stainless steel 304	Brushed
3	Bush	1	205.24.01	PA 6 - Black RAL 9005, semi gloss	Technical Smooth
2	Cover tube	1	205.04.07	Stainless steel 304	Brushed
1	Wall plate 2 (bottom logo)	1	205.09.04	Stainless steel 304	Brushed

GENERAL DIMENSION UNLESS OTHERWISE STATED ACCORDING TO DIN 7168

CLASS	NOMINAL MEASUREMENTS (mm)							
	0.5 UNTIL 3	3 UNTIL 6	6 UNTIL 30	30 UNTIL 120	120 UNTIL 400	400 UNTIL 1000	1000 UNTIL 2000	2000 UNTIL 4000
M (MIDDLE)	±0.1	±0.1	±0.2	±0.3	±0.5	±0.8	±1.2	±2

DESCRIPTION: Toilet roll holder with lid

ARTICLE NR. (packed product): 1314.1.3.09.46
(for packaging information see GDS)

DRAWN BY:	MS	GENERAL ROUGHNESS:	0,8	PROJECT:	205-Colar
CHECKED BY:	FVP	UNITS:	mm	DRAWING NR.:	205.25.00.TS
DATE:	23-5-2016	SCALE:	1:2	 Tiger Products b.v. Winde 3, PO box 11 5660 AA Geldrop The Netherlands	
STATUS:	Production	FORMAT:	A3		
PRINT DATE:	29-10-2024	SHEET:	1/3		
INT.REV.NR.:	04				

The reproduction, distribution and utilization of this document as well as the communication of its contents to others without express authorization is prohibited. Offenders will be held liable for the payment of damages. All rights reserved in the event of the grant of a patent, utility model or design. Copyright reserved.