

# FINAL DRAWING

## REVISIONS

REV.	DESCRIPTION	DATE	BY	APPROVED
1	- Material of 205.04.02 Connector changed to Zamac3. - Measurements changed.	21-6-2016	MS	WW
2	Construction changed, 205.24.03 Hinge tube, 205.24.04 Hinge end piece and DIN.928 Square weld nut are new parts.	12-7-2016	MS	WW
3	Width of 205.24.02 Arm changed.	4-10-2016	MS	WW
4	Production method and material of 205.01.02 Connector have been changed at the makers request, from Aluminium CNC milling to Zamac3 casting.	26-6-2018	MS	WW
5	Black version added.	28-7-2021	MS	FvP
6	Changed construction	23-10-2024		

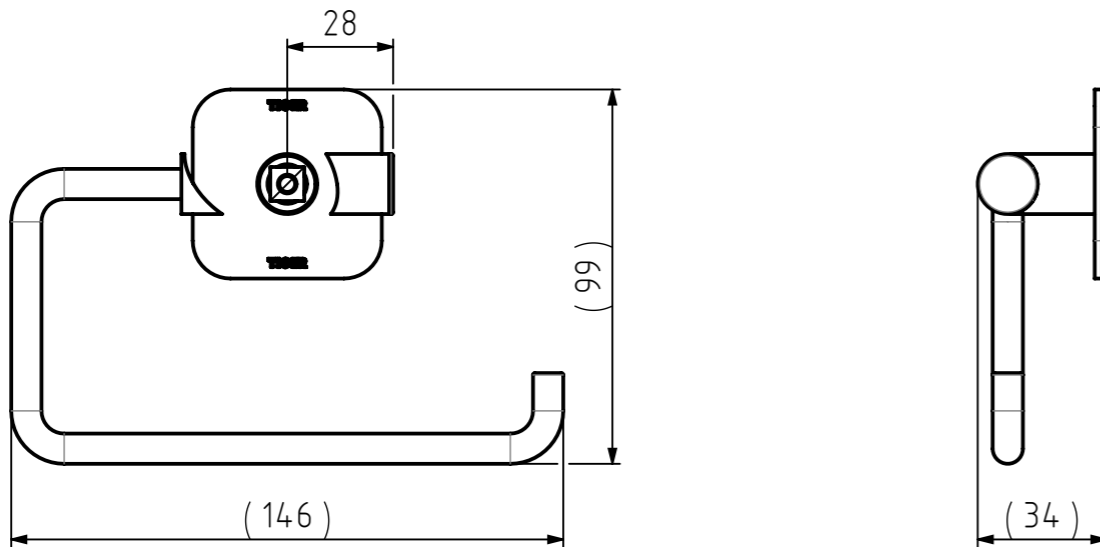
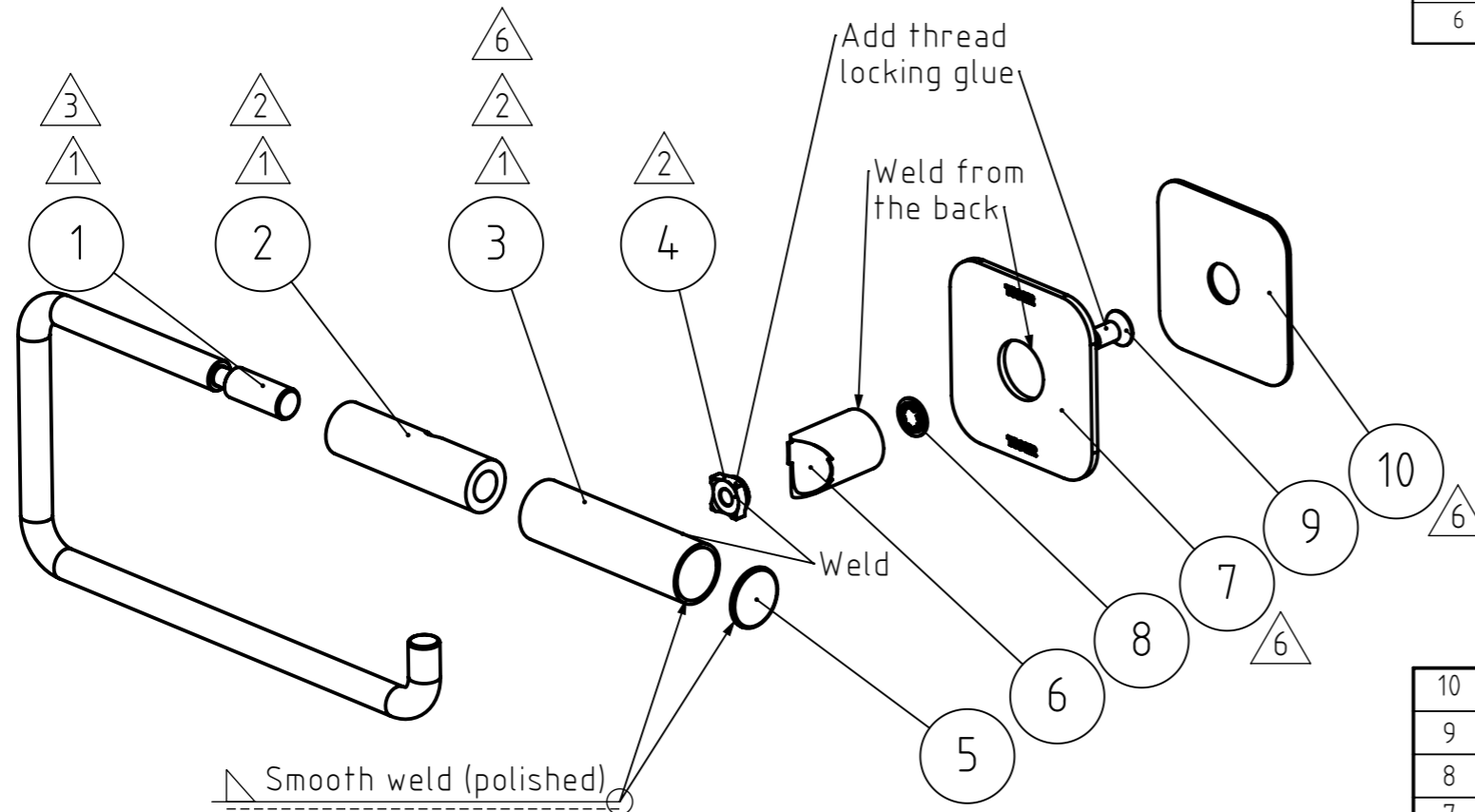

NR.	DESCRIPTION	QTY.	DRAW.NR.	MATERIAL	TREATMENT
10	Tape pad big	1	205.04.08	3M Tape VHB GPH110 1.10mm	-
9	Cross recessed countersunk head screw M5x10mm	1	ISO 7046	STAINLESS STEEL A2	-
8	Tooth lock washer with internal teeth M5	1	DIN.6797	Stainless steel A2	-
7	Wall plate 2	1	205.09.04	Stainless steel 304	Polished - High gloss
6	Cover tube	1	205.04.07	Stainless steel 304	Brushed
5	Hinge end piece	1	205.24.04	Stainless steel 304	Brushed
4	SQUARE WELD NUT, M5	1	DIN.928	STAINLESS STEEL	-
3	Hinge tube	1	205.24.03	Stainless steel 304	Brushed
2	Bush	1	205.24.01	PA 6 - Black RAL 9005, semi gloss	Technical Smooth
1	Arm	1	205.24.02	Stainless steel 304	Brushed

GENERAL DIMENSION UNLESS OTHERWISE STATED ACCORDING TO DIN 7168		DESCRIPTION:	
NOMINAL MEASUREMENTS (mm)		Toilet roll holder	
CLASS	0.5 UNTIL 3 3 UNTIL 6 6 UNTIL 30 30 UNTIL 120 120 UNTIL 400 400 UNTIL 1000 1000 UNTIL 2000 2000 UNTIL 4000	VERSION NAME: stainless steel	
M (MIDDLE)	±0.1 ±0.1 ±0.2 ±0.3 ±0.5 ±0.8 ±1.2 ±2	ARTICLE NR.: 1314030946	
PROJECTION:	GENERAL ANGLE: ±0,5°	EAN: 4008911314007	
DRAWN BY:	MS	PROJECT: 205-Colar	
CHECKED BY:		DRAWING NR.: 205.24.00.TS	
DATE:	20-5-2016	Tiger Nederland b.v. Winde 3, PO box 11 5660 AA Geldrop The Netherlands	
STATUS:	Production	SCALE: 1:2	
PRINT DATE:	14-4-2026	FORMAT: A3	
INT.REV.NR.:	04	SHEET: 1/3	

The reproduction, distribution and utilization of this document as well as the communication of its contents to others without express authorization is prohibited. Offenders will be held liable for the payment of damages. All rights reserved in the event of the grant of a patent, utility model or design. Copyright reserved.