

FINAL DRAWING

REVISIONS				
REV.	DESCRIPTION	DATE	BY	APPROVED
-	See 169.01.00.TS	-	-	-

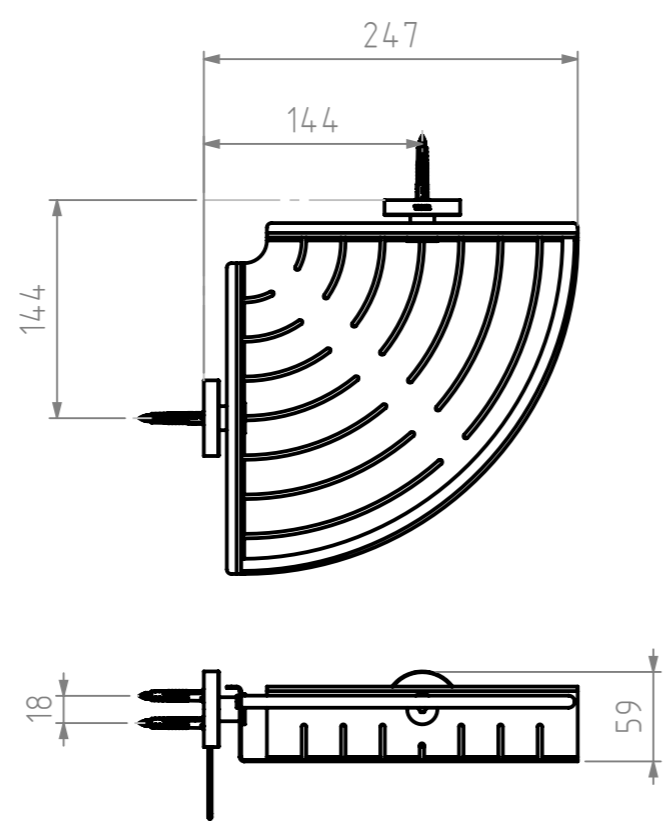
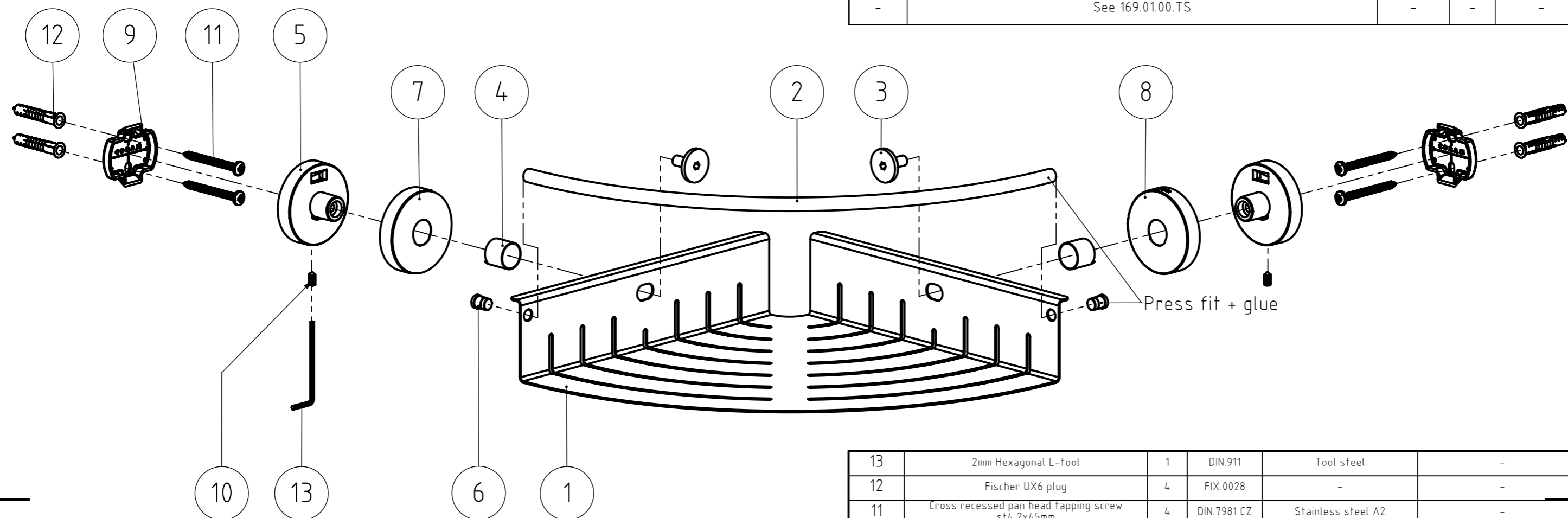

NR.	DESCRIPTION	Q.TY.	DRAW.NR.	MATERIAL	TREATMENT
13	2mm Hexagonal L-tool	1	DIN.911	Tool steel	-
12	Fischer UX6 plug	4	FIX.0028	-	-
11	Cross recessed pan head Tapping screw st4,2x45mm	4	DIN.7981 CZ	Stainless steel A2	-
10	HEX. SOCKET SET SCREW WITH CONE POINT, M4x8mm	2	DIN.0914	Stainless steel A2	-
9	Wallplate Type 1	2	226.03.02	Stainless steel AISI 304	Sand blasted
8	Cover	1	040.01.03	Stainless steel AISI 430	Powder coated, texture VDI 3400 ref.30 - RAL 9005 (Jet black)
7	Cover (no logo)	1	040.01.03	Stainless steel AISI 430	Powder coated, texture VDI 3400 ref.30 - RAL 9005 (Jet black)
6	Plug	2	169.02.03	Stainless steel AISI 430	Powder coated, texture VDI 3400 ref.30 - RAL 9005 (Jet black)
5	Wall support	2	169.01.05	Zamac3	Chromium Plated
4	Small cover	2	169.01.04	Stainless steel AISI 430	Powder coated, texture VDI 3400 ref.30 - RAL 9005 (Jet black)
3	Stop	2	169.01.03	Stainless steel AISI 430	Powder coated, texture VDI 3400 ref.30 - RAL 9005 (Jet black)
2	Round bar	1	169.01.02	Stainless steel AISI 430	Powder coated, texture VDI 3400 ref.30 - RAL 9005 (Jet black)
1	Sheet metal	1	169.01.01	Stainless steel AISI 430	Powder coated, texture VDI 3400 ref.30 - RAL 9005 (Jet black)

GENERAL DIMENSION UNLESS OTHERWISE STATED ACCORDING TO DIN 7168		DESCRIPTION:	
NOMINAL MEASUREMENTS (mm)		Corner basket	
CLASS	0.5 UNTIL 3 3 UNTIL 6 6 UNTIL 30 30 UNTIL 120 120 UNTIL 400 400 UNTIL 1000 1000 UNTIL 2000 2000 UNTIL 4000		
M (MIDDLE)	±0.1 ±0.1 ±0.2 ±0.3 ±0.5 ±0.8 ±1.2 ±2		
PROJECTION:	GENERAL ANGLE: ±0,5°	EAN: 4008913047422	VERSION NAME: black
ARTICLE NR.: 3047.3.07.46	DRAWN BY: MS		PROJECT: 169-Boston corner basket
DRAWING NR.: 169.01.00.TB		GENERAL ROUGHNESS: 0,8	TIGER Tiger Products b.v. Winde 3, PO box 11 5660 AA Geldrop The Netherlands
DATE: 6-6-2011	UNITS: mm	STATUS: Production	
PRINT DATE: 9-7-2025	SCALE: 1:5	FORMAT: A3	
INT.REV.NR.: 03	SHEET: 3/3		

The reproduction, distribution and utilization of this document as well as the communication of its contents to others without express authorization is prohibited. Offenders will be held liable for the payment of damages. All rights reserved in the event of the grant of a patent, utility model or design. Copyright reserved.