

# FINAL DRAWING

## REVISIONS

REV.	DESCRIPTION	DATE	BY	APPROVED
1	Changes made after sample check: 1. Screw ISO.4762 M5x40mm changed to ISO.7045 M5x45mm. 2. DIN.6797 M5 washer added. 3. Dimensions changed for 040.03.03 and 040.08.12.	16-4-2014	MS	WW
2	- 040.01.02 Wall bracket 2 replaced by 226.01.01 Wallplate Type 1. - Screws, plugs and L-tool added to assembly drawing. - Black version created.	11-10-2017	MS	WW

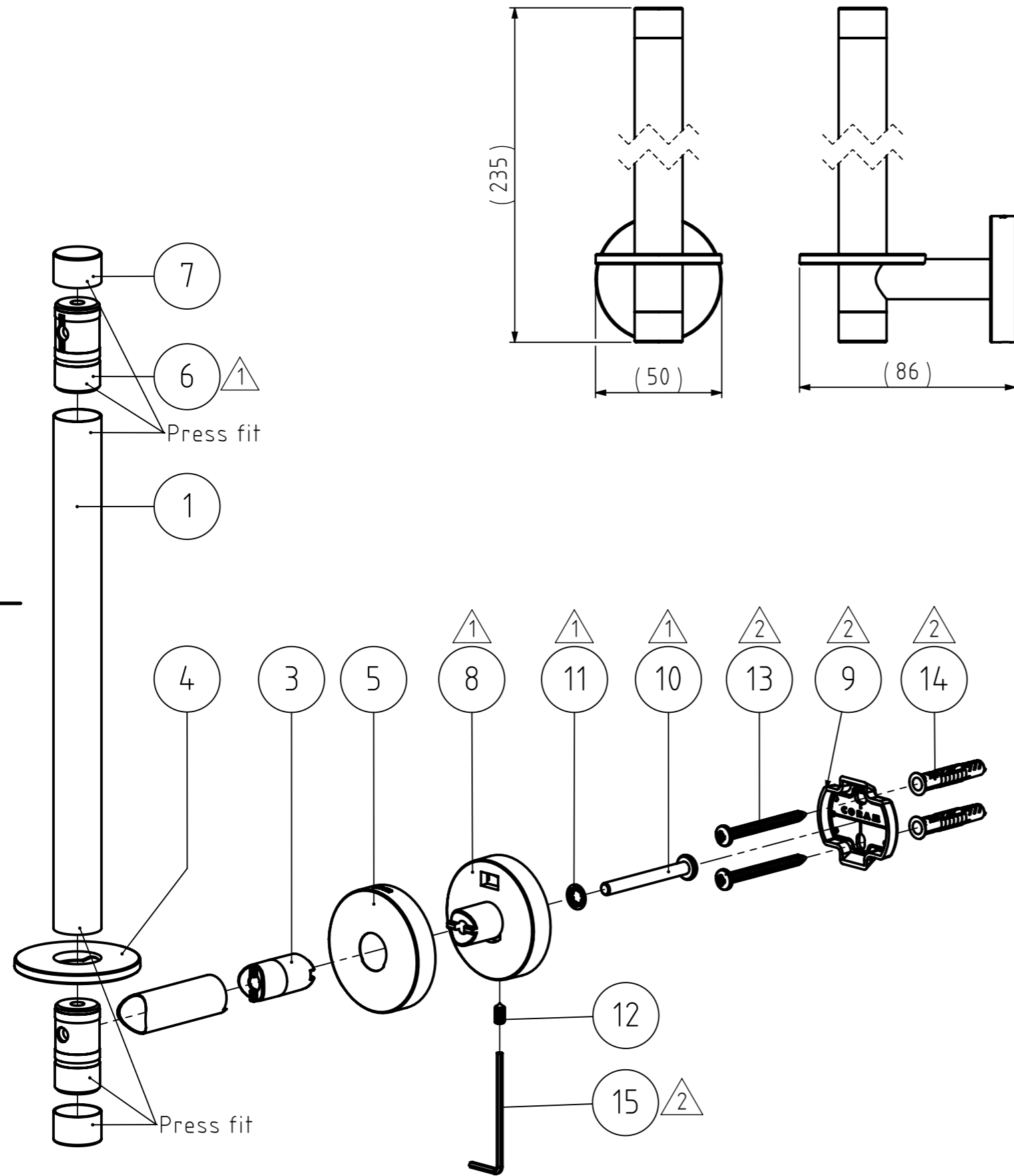

NR.	DESCRIPTION	QTY.	DRAW.NR.	MATERIAL	TREATMENT
15	2mm Hexagonal L-tool	1	DIN.911	Tool steel	-
14	Fischer UX6 plug	2	FIX.0028	-	-
13	Cross recessed pan head tapping screw st4,2x45mm	2	DIN.7981 CZ	Stainless steel A2	-
12	HEX. SOCKET SET SCREW WITH CONE POINT, M4x8mm	1	DIN.0914	Stainless steel A2	-
11	Tooth lock washer with internal teeth M5	1	DIN.6797	Stainless steel A2	-
10	CROSS RECESSED RAISED CHEESE HEAD SCREW M5x45mm	1	ISO.7045	Stainless steel A2	-
9	Wallplate Type 1	1	226.03.02	Stainless steel AISI 304	Sand blasted
8	Wall support	1	040.08.12	Zamac3	Chromium Plated
7	End cap	2	040.03.07	Stainless steel AISI 304	Polished - High gloss
6	Tube connector A	2	040.03.03	Zamac3	Chromium Plated
5	Cover	1	040.01.03	Stainless steel AISI 304	Polished - High gloss
4	Ring carrier	1	179.02.04	PP - Transparant white	Texture VDI 3400 ref.27 (light)
3	Extension bush	1	179.02.03	Zamac3	Chromium Plated
2	Support tube	1	179.02.02	Stainless steel AISI 304	Polished - High gloss
1	Centerpiece cover	1	179.02.01	Stainless steel AISI 304	Polished - High gloss

GENERAL DIMENSION UNLESS OTHERWISE STATED ACCORDING TO DIN 7168		DESCRIPTION:	
NOMINAL MEASUREMENTS (mm)		Spare toilet roll holder	
CLASS	0.5 UNTIL 3 3 UNTIL 6 6 UNTIL 30 30 UNTIL 120 120 UNTIL 400 400 UNTIL 1000 1000 UNTIL 2000 2000 UNTIL 4000		
M (MIDDLE)	±0.1 ±0.1 ±0.2 ±0.3 ±0.5 ±0.8 ±1.2 ±2		
PROJECTION:	GENERAL ANGLE: ±0,5°	EAN: 4008913054406	VERSION NAME: chrome
ARTICLE NR.: 3054.3.03.46			
DRAWN BY: MS	GENERAL ROUGHNESS: 0,8 ✓	PROJECT: 179-Boston Spare roll holder	<b>TIGER</b> Tiger Products b.v. Winde 3, PO box 11 5660 AA Geldrop The Netherlands
CHECKED BY: MS		DRAWING NR.: 179.02.00.TC	
DATE: 30-1-2014	UNITS: mm		
STATUS: Production	SCALE: 1:2		
PRINT DATE: 4-10-2024	FORMAT: A3		
INT.REV.NR.: 02	SHEET: 1/3		

The reproduction, distribution and utilization of this document as well as the communication of its contents to others without express authorization is prohibited. Offenders will be held liable for the payment of damages. All rights reserved in the event of the grant of a patent, utility model or design. Copyright reserved.