

# FINAL DRAWING

REVISIONS				
REV.	DESCRIPTION	DATE	BY	APPROVED
1	Connection between parts changed for 'stainless steel' version.	24-10-2017	MS	MS

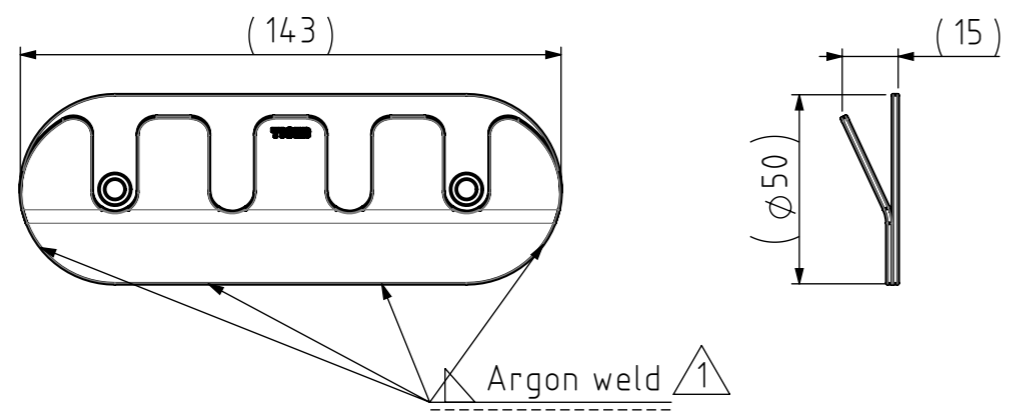
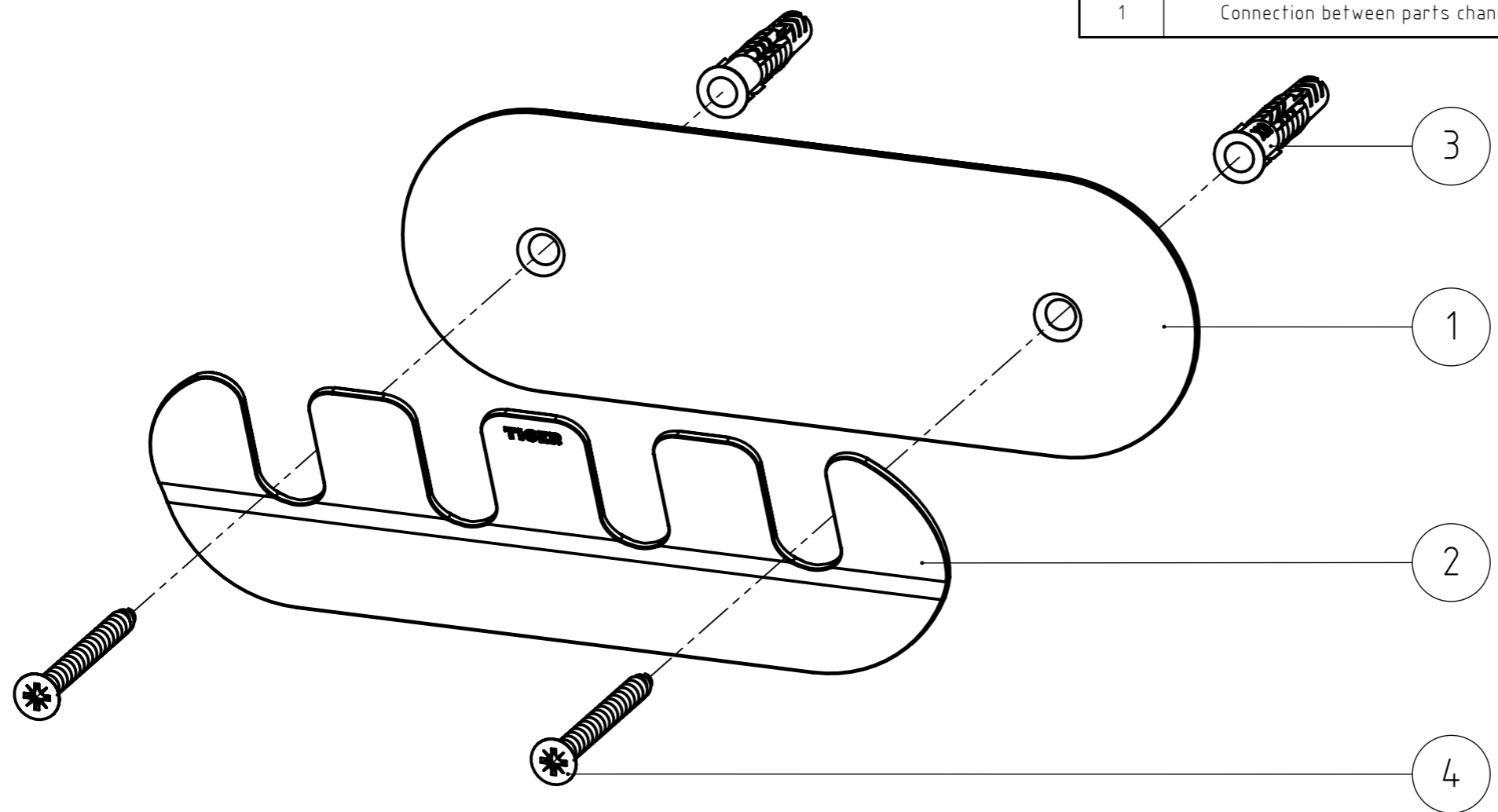

Remarks:  
- Position the argon welds towards the back to hide the dent.

NR.	DESCRIPTION	QTY.	DRAW.NR.	MATERIAL	TREATMENT
4	Cross recessed countersunk head tapping screw	2	DIN.7982 C	Stainless steel A2	-
3	Fischer UX6 plug	2	FIX.0028	-	-
2	Front part	1	225.21.02	Stainless steel 304	Brushed
1	Back part	1	225.21.01	Stainless steel 304	Brushed

GENERAL DIMENSION UNLESS OTHERWISE STATED ACCORDING TO DIN 7168							DESCRIPTION:					
CLASS	NOMINAL MEASUREMENTS (mm)							Round rack				
	0.5 UNTIL 3	3 UNTIL 6	6 UNTIL 30	30 UNTIL 120	120 UNTIL 400	400 UNTIL 1000	1000 UNTIL 2000			2000 UNTIL 4000		
M (MIDDLE)	±0.1	±0.1	±0.2	±0.3	±0.5	±0.8	±1.2	±2	VERSION NAME: stainless steel	ARTICLE NR.: 11171.3.09.42		
PROJECTION:	GENERAL ANGLE: ±0,5°			EAN: 4008911117011		PROJECT: 225-hooks 2016						
DRAWN BY:	MS		GENERAL ROUGHNESS:		0,8		DRAWING NR.: 225.21.00.TS		 Tiger Products b.v. Winde 3, PO box 11 5660 AA Geldrop The Netherlands			
CHECKED BY:	FVP		UNITS:		mm		SCALE:				1:2	
DATE:	6-10-2016		FORMAT:		A3		SHEET:				1/2	
STATUS:	Production		PRINT DATE:		7-4-2026		INT.REV.NR.:				01	

The reproduction, distribution and utilization of this document as well as the communication of its contents to others without express authorization is prohibited. Offenders will be held liable for the payment of damages. All rights reserved in the event of the grant of a patent, utility model or design. Copyright reserved.