

QUICKCHANGE

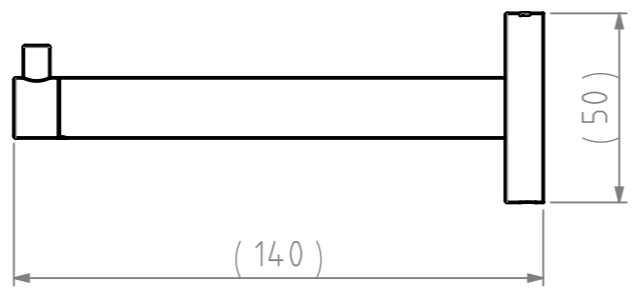
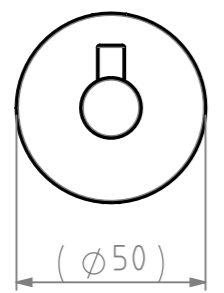
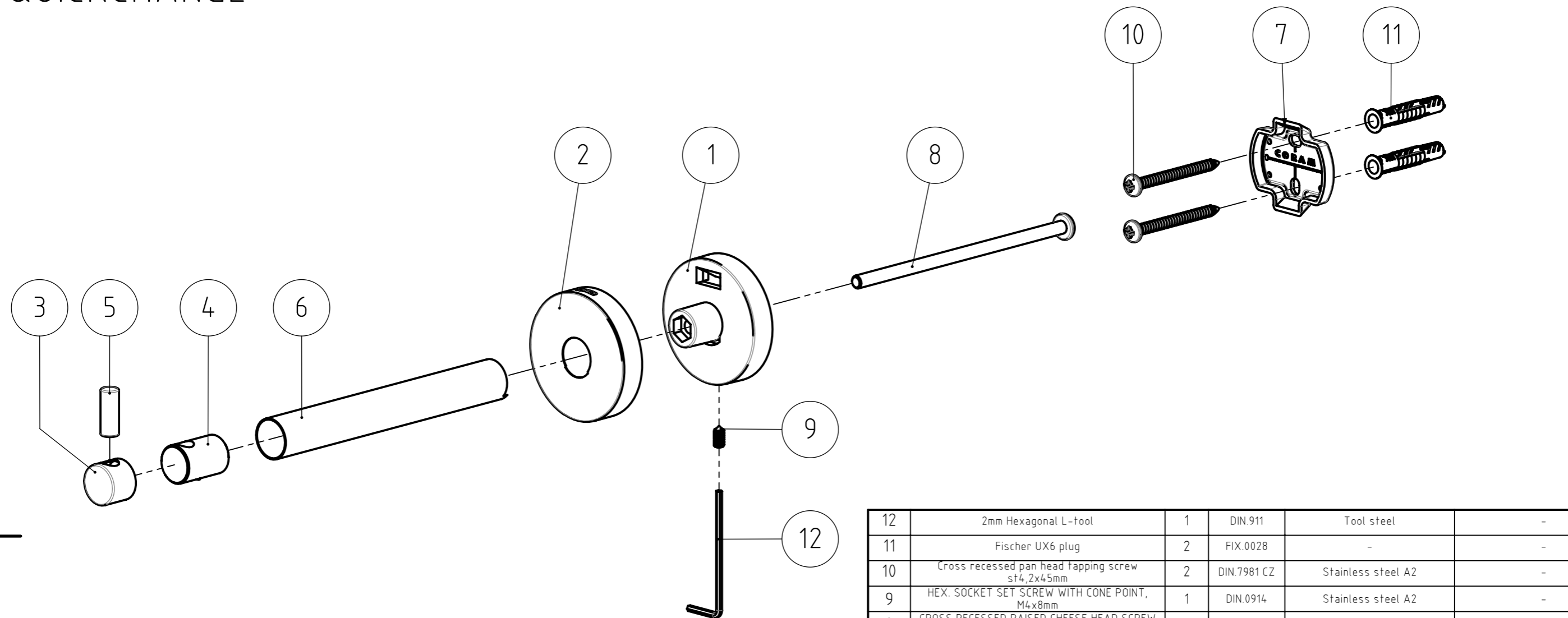

NR.	DESCRIPTION	QTY.	DRAW.NR.	MATERIAL	TREATMENT
12	2mm Hexagonal L-tool	1	DIN.911	Tool steel	-
11	Fischer UX6 plug	2	FIX.0028	-	-
10	Cross recessed pan head tapping screw st4,2x4,5mm	2	DIN.7981 CZ	Stainless steel A2	-
9	HEX. SOCKET SET SCREW WITH CONE POINT, M4x8mm	1	DIN.0914	Stainless steel A2	-
8	CROSS RECESSED RAISED CHEESE HEAD SCREW M5x110mm	1	ISO.7045	Stainless steel A2	-
7	Wallplate Type 1	1	226.03.02	Stainless steel AISI 304	Sand blasted
6	Support tube F	1	040.11.01	Stainless steel AISI 304	Brushed
5	Hook	1	040.10.04	Stainless steel AISI 304	Brushed
4	Arm holder	1	040.10.03	Zamac3	Chromium Plated
3	Hook cap	1	040.10.02	Stainless steel AISI 304	Brushed
2	Cover	1	040.01.03	Stainless steel AISI 304	Brushed
1	Wall support	1	040.01.01	Zamac3	Chromium Plated

GENERAL DIMENSION UNLESS OTHERWISE STATED ACCORDING TO DIN 7168		DESCRIPTION:																										
<table border="1"> <thead> <tr> <th rowspan="2">CLASS</th> <th colspan="7">NOMINAL MEASUREMENTS (mm)</th> </tr> <tr> <th>0.5 UNTIL 3</th> <th>3 UNTIL 6</th> <th>6 UNTIL 30</th> <th>30 UNTIL 120</th> <th>120 UNTIL 400</th> <th>400 UNTIL 1000</th> <th>1000 UNTIL 2000</th> <th>2000 UNTIL 4000</th> </tr> </thead> <tbody> <tr> <td>M (MIDDLE)</td> <td>± 0.1</td> <td>± 0.1</td> <td>± 0.2</td> <td>± 0.3</td> <td>± 0.5</td> <td>± 0.8</td> <td>± 1.2</td> <td>± 2</td> </tr> </tbody> </table>		CLASS	NOMINAL MEASUREMENTS (mm)							0.5 UNTIL 3	3 UNTIL 6	6 UNTIL 30	30 UNTIL 120	120 UNTIL 400	400 UNTIL 1000	1000 UNTIL 2000	2000 UNTIL 4000	M (MIDDLE)	± 0.1	± 0.1	± 0.2	± 0.3	± 0.5	± 0.8	± 1.2	± 2	<p>DESCRIPTION: Spare toilet roll holder</p>	
CLASS	NOMINAL MEASUREMENTS (mm)																											
	0.5 UNTIL 3	3 UNTIL 6	6 UNTIL 30	30 UNTIL 120	120 UNTIL 400	400 UNTIL 1000	1000 UNTIL 2000	2000 UNTIL 4000																				
M (MIDDLE)	± 0.1	± 0.1	± 0.2	± 0.3	± 0.5	± 0.8	± 1.2	± 2																				
<p>PROJECTION: </p> <p>GENERAL ANGLE: $\pm 0,5^\circ$</p> <p>EAN: 4008913079409</p>		<p>VERSION NAME: stainless steel</p> <p>ARTICLE NR.: 3079.3.09.46</p>																										
<p>DRAWN BY: EV</p> <p>CHECKED BY: -</p> <p>DATE: 25-8-2006</p> <p>STATUS: Production</p> <p>PRINT DATE: 3-10-2024</p> <p>INT.REV.NR.: 01</p>		<p>PROJECT: 040-Boston</p> <p>DRAWING NR.: 040.11.00.TS</p> <p>GENERAL ROUGHNESS: $0,8 \sqrt{\text{ }}$</p> <p>UNITS: mm</p> <p>SCALE: 1:2</p> <p>FORMAT: A3</p> <p>SHEET: 2/2</p>																										
		<p>TIGER</p> <p>Tiger Nederland b.v. Winde 3, PO box 11 5660 AA Geldrop The Netherlands</p>																										

The reproduction, distribution and utilization of this document as well as the communication of its contents to others without express authorization is prohibited. Offenders will be held liable for the payment of damages. All rights reserved in the event of the grant of a patent, utility model or design. Copyright reserved.