

# FINAL DRAWING

REVISIONS				
REV.	DESCRIPTION	DATE	BY	APPROVED
-	See 205.24.00.TS	-	-	-

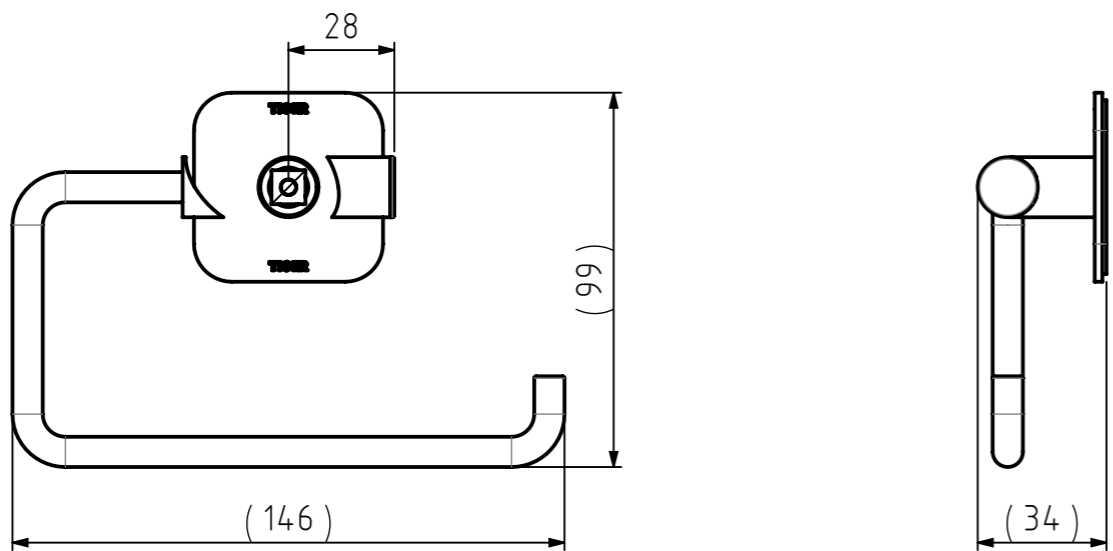
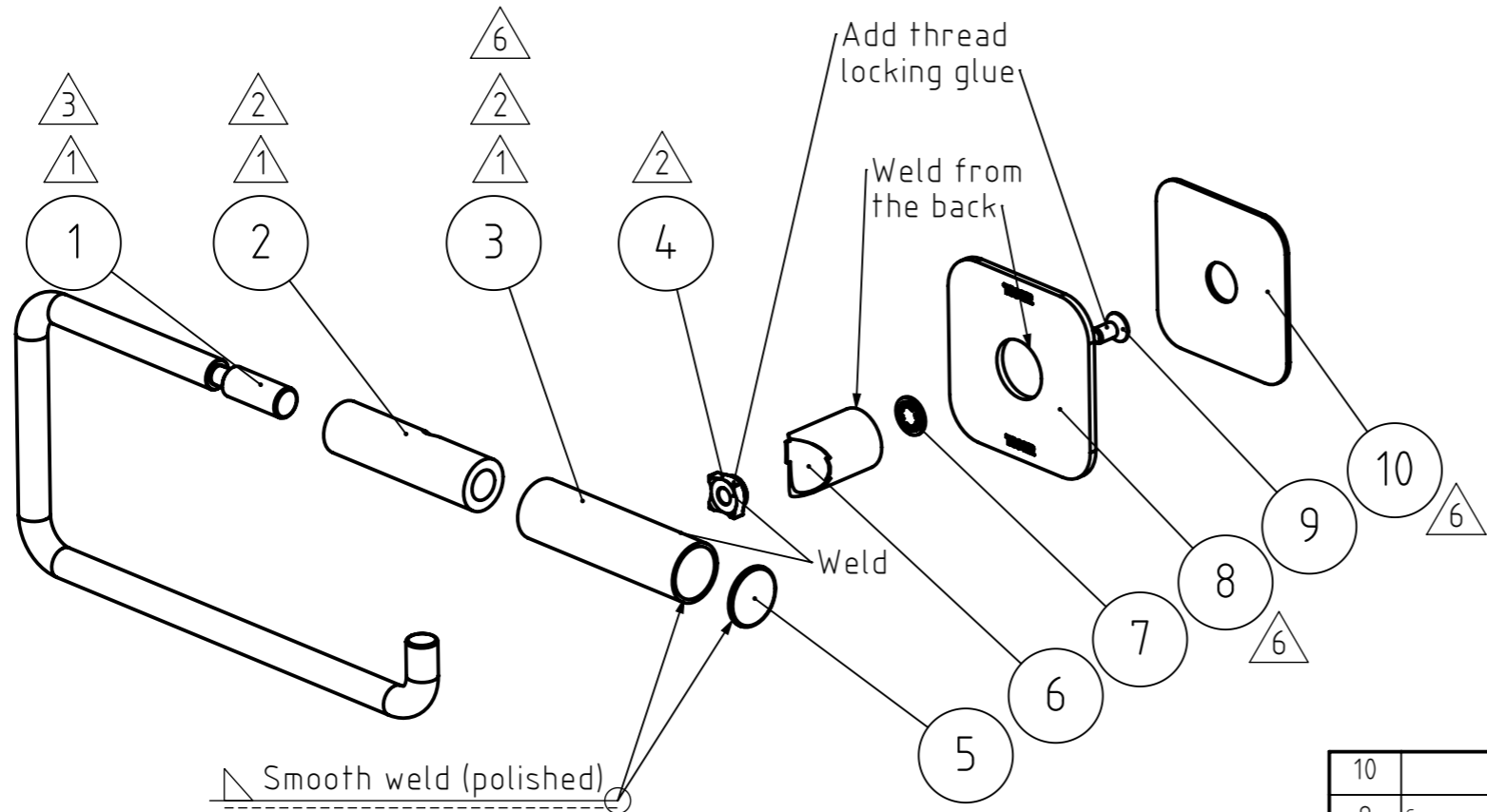

NR.	DESCRIPTION	QTY.	DRAW.NR.	MATERIAL	TREATMENT
10	Tape pad big	1	205.04.08	3M Tape VHB GPH110 1.10mm	-
9	Cross recessed countersunk head screw M4x8mm	1	ISO 7046	STAINLESS STEEL A2	-
8	Wall plate 2	1	205.09.04	Stainless steel 304	Polished - High gloss
7	Tooth lock washer with internal teeth M5	1	DIN.6797	Stainelss steel A2	-
6	Cover tube	1	205.04.07	Stainless steel 304	Polished - High gloss
5	Hinge end piece	1	205.24.04	Stainless steel 304	Polished - High gloss
4	SQUARE WELD NUT, M5	1	DIN.928	STAINLESS STEEL	-
3	Hinge tube	1	205.24.03	Stainless steel 304	Polished - High gloss
2	Bush	1	205.24.01	PA 6 - Black RAL 9005, semi gloss	Technical Smooth
1	Arm	1	205.24.02	Stainless steel 304	Polished - High gloss

GENERAL DIMENSION UNLESS OTHERWISE STATED ACCORDING TO DIN 7168		DESCRIPTION:																										
<table border="1"> <thead> <tr> <th rowspan="2">CLASS</th> <th colspan="7">NOMINAL MEASUREMENTS (mm)</th> </tr> <tr> <th>0.5 UNTIL 3</th> <th>3 UNTIL 6</th> <th>6 UNTIL 30</th> <th>30 UNTIL 120</th> <th>120 UNTIL 400</th> <th>400 UNTIL 1000</th> <th>1000 UNTIL 2000</th> <th>2000 UNTIL 4000</th> </tr> </thead> <tbody> <tr> <td>M (MIDDLE)</td> <td>±0.1</td> <td>±0.1</td> <td>±0.2</td> <td>±0.3</td> <td>±0.5</td> <td>±0.8</td> <td>±1.2</td> <td>±2</td> </tr> </tbody> </table>		CLASS	NOMINAL MEASUREMENTS (mm)							0.5 UNTIL 3	3 UNTIL 6	6 UNTIL 30	30 UNTIL 120	120 UNTIL 400	400 UNTIL 1000	1000 UNTIL 2000	2000 UNTIL 4000	M (MIDDLE)	±0.1	±0.1	±0.2	±0.3	±0.5	±0.8	±1.2	±2	Toilet roll holder	
CLASS	NOMINAL MEASUREMENTS (mm)																											
	0.5 UNTIL 3	3 UNTIL 6	6 UNTIL 30	30 UNTIL 120	120 UNTIL 400	400 UNTIL 1000	1000 UNTIL 2000	2000 UNTIL 4000																				
M (MIDDLE)	±0.1	±0.1	±0.2	±0.3	±0.5	±0.8	±1.2	±2																				
PROJECTION:		VERSION NAME: chrome																										
GENERAL ANGLE: ±0,5°		ARTICLE NR.: 1314030346																										
EAN: 4008911314052		PROJECT: 205-Colar																										
DRAWN BY: MS		DRAWING NR.: 205.24.00.TC																										
CHECKED BY:		TIGER																										
DATE: 20-5-2016		Tiger Nederland b.v.																										
STATUS: Production		Winde 3, PO box 11																										
PRINT DATE: 14-4-2026		5660 AA Geldrop																										
INT.REV.NR.: 04		The Netherlands																										
GENERAL ROUGHNESS: 0,8/√																												
UNITS: mm																												
SCALE: 1:2																												
FORMAT: A3																												
SHEET: 2/3																												

The reproduction, distribution and utilization of this document as well as the communication of its contents to others without express authorization is prohibited. Offenders will be held liable for the payment of damages. All rights reserved in the event of the grant of a patent, utility model or design. Copyright reserved.