

FINAL DRAWING

REVISIONS				
REV.	DESCRIPTION	DATE	BY	APPROVED
-	See 205.25.00.TS	-	-	-

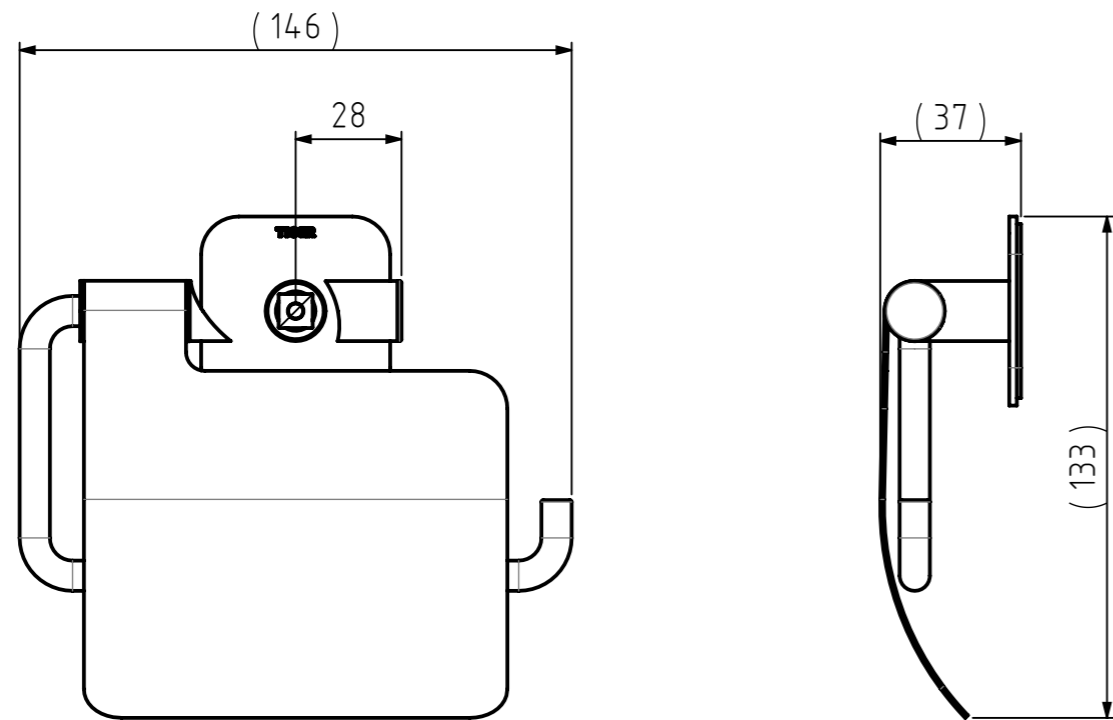
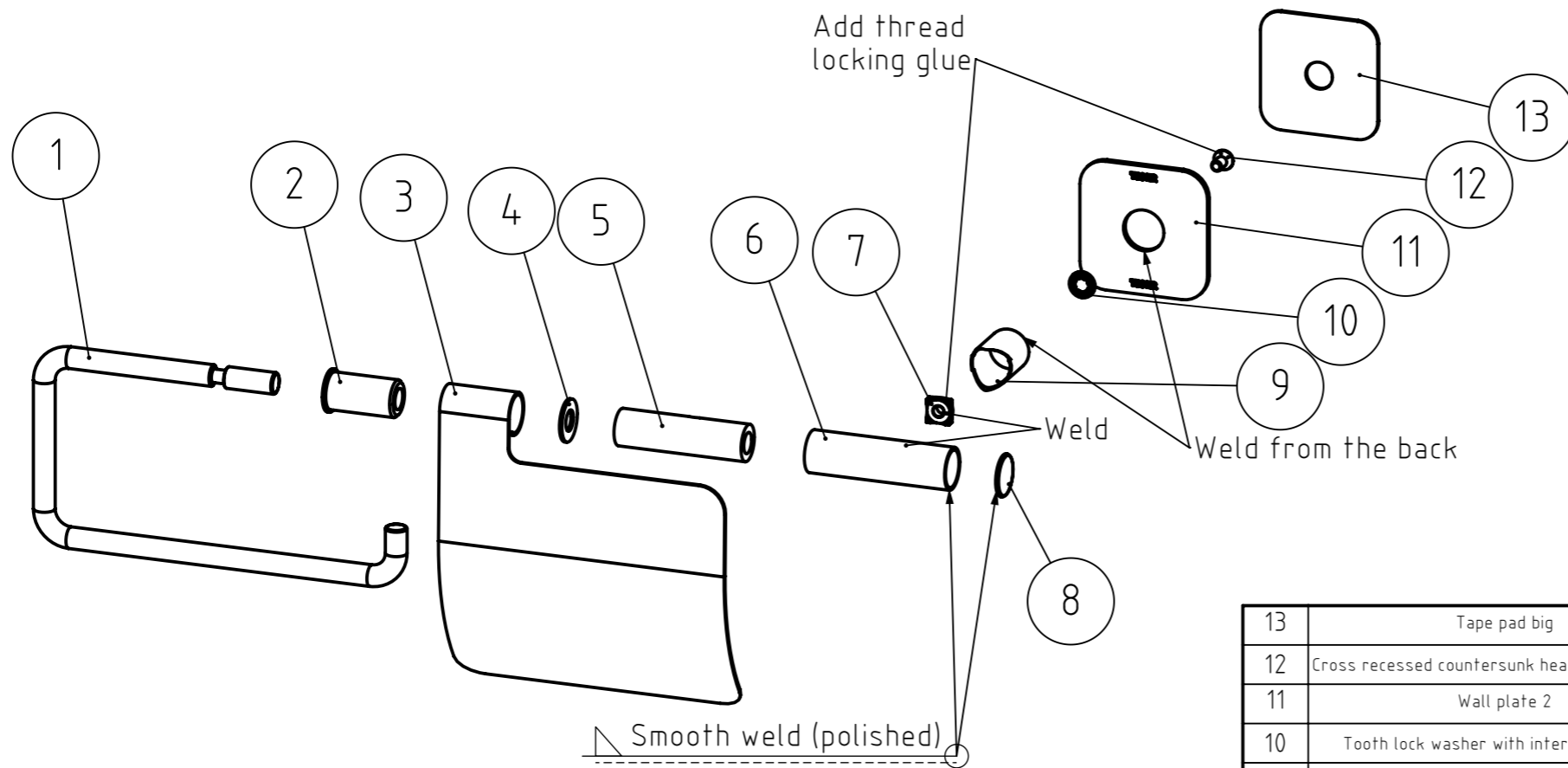

NR.	DESCRIPTION	QTY.	DRAW.NR.	MATERIAL	TREATMENT
13	Tape pad big	1	205.04.08	3M Tape VHB GPH110 1.10mm	-
12	Cross recessed countersunk head screw M4x8mm	1	ISO 7046	STAINLESS STEEL A2	-
11	Wall plate 2	1	205.09.04	Stainless steel 304	Polished - High gloss
10	Tooth lock washer with internal teeth M5	1	DIN.6797	Stainless steel A2	-
9	Cover tube	1	205.04.07	Stainless steel 304	Polished - High gloss
8	Hinge end piece	1	205.24.04	Stainless steel 304	Polished - High gloss
7	SQUARE WELD NUT, M5	1	DIN.928	STAINLESS STEEL	-
6	Hinge tube	1	205.24.03	Stainless steel 304	Polished - High gloss
5	Bush	1	205.24.01	PA 6 - Black RAL 9005, semi gloss	Technical Smooth
4	Ring	1	205.25.03	PA 6 - Black RAL 9005, semi gloss	Technical Smooth
3	Lid	1	205.25.01	Stainless steel 304	Polished - High gloss
2	Bush	1	205.25.02	PA 6 - Black RAL 9005, semi gloss	Technical Smooth
1	Arm	1	205.24.02	Stainless steel 304	Polished - High gloss

GENERAL DIMENSION UNLESS OTHERWISE STATED ACCORDING TO DIN 7168

CLASS	NOMINAL MEASUREMENTS (mm)							
	0.5 UNTIL 3	3 UNTIL 6	6 UNTIL 30	30 UNTIL 120	120 UNTIL 400	400 UNTIL 1000	1000 UNTIL 2000	2000 UNTIL 4000
M (MIDDLE)	±0.1	±0.1	±0.2	±0.3	±0.5	±0.8	±1.2	±2

DESCRIPTION: Toilet roll holder with lid

ARTICLE NR. (packed product): 1314.1.3.03.46
(for packaging information see GDS)

VERSION NAME: chrome

GENERAL ANGLE: ±0,5°

DRAWN BY:	MS	GENERAL ROUGHNESS:	0,8	PROJECT:	205-Colar
CHECKED BY:	FVP	UNITS:	mm	DRAWING NR.:	205.25.00.TC
DATE:	23-5-2016	SCALE:	1:2	TIGER Tiger Products b.v. Winde 3, PO box 11 5660 AA Geldrop The Netherlands	
STATUS:	Production	FORMAT:	A3		
PRINT DATE:	29-10-2024	SHEET:	2/3		
INT.REV.NR.:	04				

The reproduction, distribution and utilization of this document as well as the communication of its contents to others without express authorization is prohibited. Offenders will be held liable for the payment of damages. All rights reserved in the event of the grant of a patent, utility model or design. Copyright reserved.