

FINAL DRAWING

REVISIONS				
REV.	DESCRIPTION	DATE	BY	APPROVED
-	See 207.03.00.TS	-	-	-

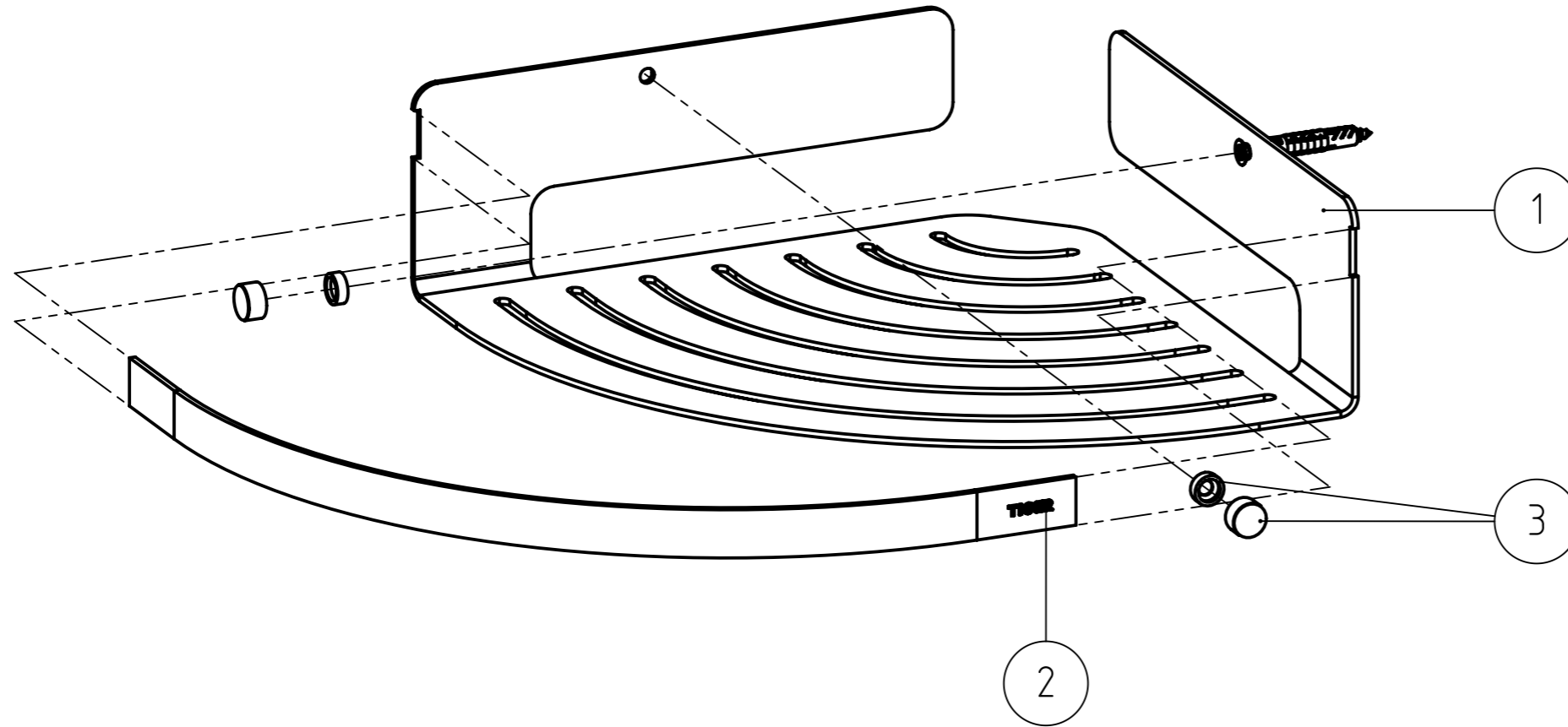

Smooth welds (grinded)

Remarks:

- Only weld on the back side.
- Add '9953.1.80.50 - Fixationset Info 4,5 x 45 mm RVS A2 (Vigo-style)'

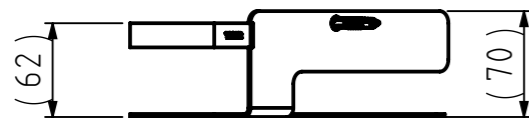
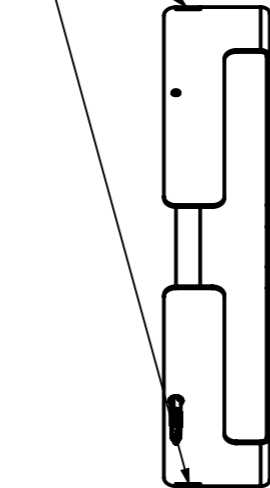
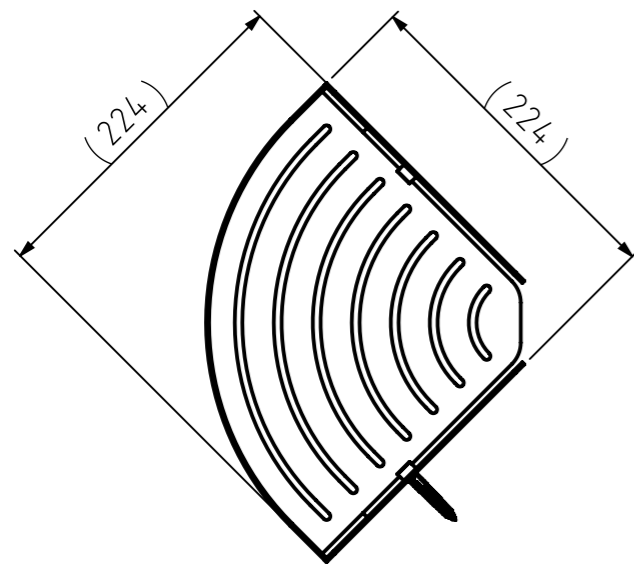

NR.	DESCRIPTION	QTY.	DRAW.NR.	MATERIAL	TREATMENT
5	Fischer UX6 plug	1	FIX.0028	-	-
4	Cross recessed countersunk head tapping screw	1	DIN.7982 CZ	Stainless steel A2	-
3	Screw cap assembly (11,5x6,2mm)	2	BUY.15.00	-	Chromium Plated
2	Corner strip large	1	207.03.02	Stainless steel AISI 430	Chromium Plated
1	Corner basket large	1	207.03.01	Stainless steel AISI 430	Chromium Plated

GENERAL DIMENSION UNLESS OTHERWISE STATED ACCORDING TO DIN 7168								DESCRIPTION:	
CLASS	NOMINAL MEASUREMENTS (mm)							Corner basket large	
	0.5 UNTIL 3	3 UNTIL 6	6 UNTIL 30	30 UNTIL 120	120 UNTIL 400	400 UNTIL 1000	1000 UNTIL 2000		
M (MIDDLE)	±0.1	±0.1	±0.2	±0.3	±0.5	±0.8	±1.2	±2	
PROJECTION:	GENERAL ANGLE:		EAN:		VERSION NAME:			ARTICLE NR.:	
	±0,5°		4008911400052		chrome			14006.3.03.46	
DRAWN BY:	MS		GENERAL ROUGHNESS:		PROJECT:			TIGER Tiger Nederland b.v. Winde 3, PO box 11 5660 AA Geldrop The Netherlands	
CHECKED BY:	FVP		0,8/√		207-Caddy				
DATE:	30-10-2013		UNITS:		DRAWING NR.:				
STATUS:	Production		mm		207.03.00.TC				
PRINT DATE:	1-4-2026		SCALE:		FORMAT:				
INT.REV.NR.:	05		SHEET:		2/3				

The reproduction, distribution and utilization of this document as well as the communication of its contents to others without express authorization is prohibited. Offenders will be held liable for the payment of damages. All rights reserved in the event of the grant of a patent, utility model or design. Copyright reserved.