

FINAL DRAWING

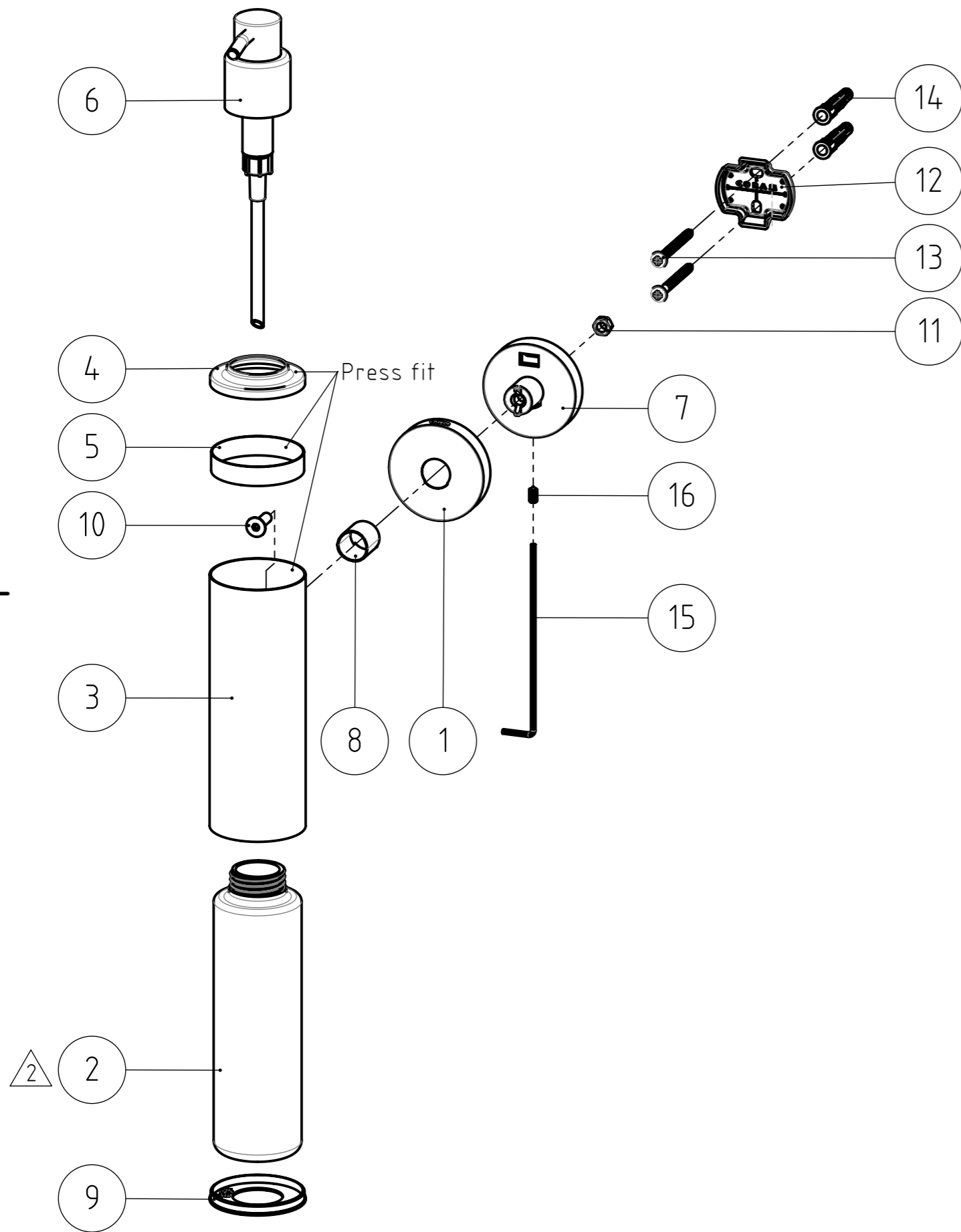

REVISIONS				
REV.	DESCRIPTION	DATE	BY	APPROVED
1	WALLBRACKET CONSTRUCTION MODIFIED + BOTTOM COVER ADDED	9-11-2009	FH	-
2	Wall thickness of Bottle changed.	4-10-2022	MS	-

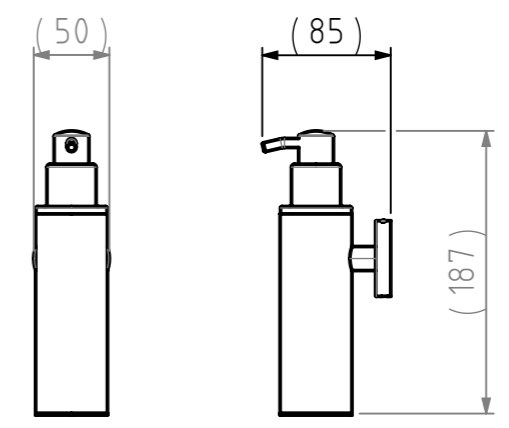

NR.	DESCRIPTION	QTY.	DRAW.NR.	MATERIAL	TREATMENT
16	HEX. SOCKET SET SCREW WITH CONE POINT, M4x8mm	1	DIN.0914	Stainless steel A2	-
15	2mm Hexagonal L-fool long, L=100mm	1	DIN.911	Tool steel	-
14	Fischer UX6 plug	2	FIX.0028	-	-
13	Cross recessed pan head tapping screw st4,2x4,5mm	2	DIN.7981 CZ	Stainless steel A2	-
12	Wallplate Type 1	1	226.03.02	Stainless steel AISI 304	Sand blasted
11	SELF PREVAILING NUT, M5	1	DIN.0985	Stainless steel A2	-
10	HEX. SOCKET COUNTERSUNK (SMALL) HEAD SCREW, M5x16mm	1	DIN 7991	Stainless steel A2	-
9	Bottom cover	1	130.01.08	PP - Black RAL 9005, semi gloss	Texture VDI 3400 ref.30 (standard)
8	Support tube	1	130.01.02	Stainless steel AISI 304	Polished - High gloss
7	Wall support	1	130.01.01	Zamac3	Chromium Plated
6	PUMP UNIT (BOSTON TYPE)	1	BUY.0001	stainless steel 304	Chromium Plated
5	Pipe	1	040.04.05	Stainless steel AISI 304	-
4	Bottle top cup	1	040.04.04	Stainless steel AISI 304	Polished - High gloss
3	Bottle housing	1	040.04.03	Stainless steel AISI 304	Polished - High gloss
2	Bottle	1	040.04.02	PET	-
1	Cover	1	040.01.03	Stainless steel AISI 304	Polished - High gloss

GENERAL DIMENSION UNLESS OTHERWISE STATED ACCORDING TO DIN 7168		DESCRIPTION:	
NOMINAL MEASUREMENTS (mm)		Soap dispenser	
CLASS	0.5 UNTIL 3 3 UNTIL 6 6 UNTIL 30 30 UNTIL 120 120 UNTIL 400 400 UNTIL 1000 1000 UNTIL 2000 2000 UNTIL 4000		
M (MIDDLE)	±0.1 ±0.1 ±0.2 ±0.3 ±0.5 ±0.8 ±1.2 ±2	VERSION NAME: chrome	
PROJECTION:	GENERAL ANGLE: ±0,5°	ARTICLE NR.: 3085.3.03.46	
	EAN: 4008913085417	PROJECT: 040-Boston	
DRAWN BY: EV	GENERAL ROUGHNESS: 0,8 ✓	DRAWING NR.: 040.04.00.TC	
CHECKED BY: -	DATE: 25-7-2006	TIGER Tiger Nederland b.v. Winde 3, PO box 11 5660 AA Geldrop The Netherlands	
STATUS: Production	UNITS: mm		
PRINT DATE: 3-10-2024	SCALE: 1:5		
INT.REV.NR.: 0000	FORMAT: A3		
	SHEET: 1/2		

The reproduction, distribution and utilization of this document as well as the communication of its contents to others without express authorization is prohibited. Offenders will be held liable for the payment of damages. All rights reserved in the event of the grant of a patent, utility model or design. Copyright reserved.