

# FINAL DRAWING

| REVISIONS |                                                                                                                                                         |            |    |          |
|-----------|---------------------------------------------------------------------------------------------------------------------------------------------------------|------------|----|----------|
| REV.      | DESCRIPTION                                                                                                                                             | DATE       | BY | APPROVED |
| 1         | - 040.01.02 Wall bracket 2 replaced by 226.01.01 Wallplate Type 1.<br>- Screws, plugs and L-tool added to assembly drawing.<br>- Black version created. | 11-10-2017 | MS | WW       |

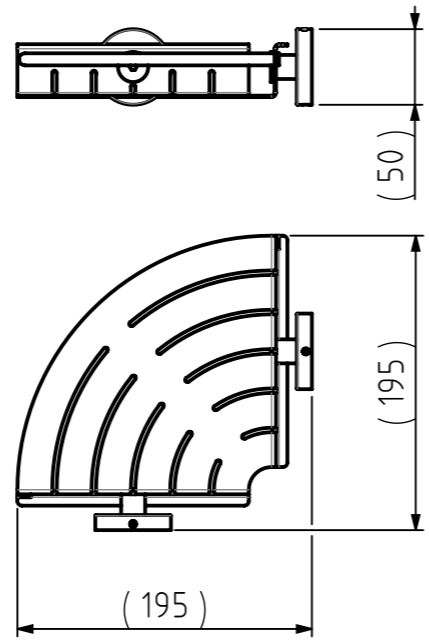
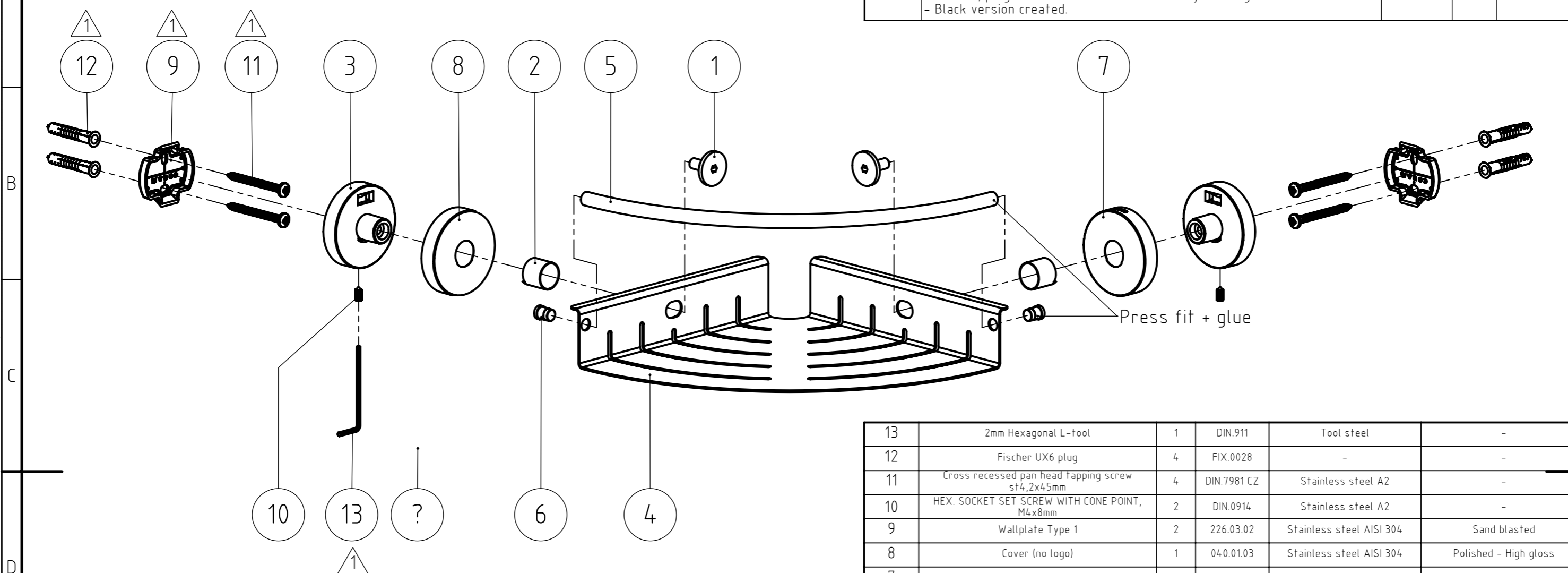

| ART.NR. | DESCRIPTION                                      | QTY. | DRAW.NR.    | MATERIAL                 | TREATMENT             |
|---------|--------------------------------------------------|------|-------------|--------------------------|-----------------------|
| 13      | 2mm Hexagonal L-tool                             | 1    | DIN.911     | Tool steel               | -                     |
| 12      | Fischer UX6 plug                                 | 4    | FIX.0028    | -                        | -                     |
| 11      | Cross recessed pan head tapping screw s14,2x45mm | 4    | DIN.7981 CZ | Stainless steel A2       | -                     |
| 10      | HEX. SOCKET SET SCREW WITH CONE POINT, M4x8mm    | 2    | DIN.0914    | Stainless steel A2       | -                     |
| 9       | Wallplate Type 1                                 | 2    | 226.03.02   | Stainless steel AISI 304 | Sand blasted          |
| 8       | Cover (no logo)                                  | 1    | 040.01.03   | Stainless steel AISI 304 | Polished - High gloss |
| 7       | Cover                                            | 1    | 040.01.03   | Stainless steel AISI 304 | Polished - High gloss |
| 6       | Plug                                             | 2    | 169.02.03   | Stainless steel AISI 304 | -                     |
| 5       | Round bar 1680                                   | 1    | 169.02.02   | Stainless steel AISI 304 | Polished - High gloss |
| 4       | Sheet metal                                      | 1    | 169.02.01   | Stainless steel AISI 304 | Polished - High gloss |
| 3       | Wall support                                     | 2    | 169.01.05   | Zamac3                   | Chromium Plated       |
| 2       | Small cover                                      | 2    | 169.01.04   | Stainless steel AISI 304 | Polished - High gloss |
| 1       | Stop                                             | 2    | 169.01.03   | Stainless steel AISI 304 | Polished - High gloss |

|                                                                 |                                                                                                                                 |                          |                                   |
|-----------------------------------------------------------------|---------------------------------------------------------------------------------------------------------------------------------|--------------------------|-----------------------------------|
| GENERAL DIMENSION UNLESS OTHERWISE STATED ACCORDING TO DIN 7168 |                                                                                                                                 | DESCRIPTION:             |                                   |
| NOMINAL MEASUREMENTS (mm)                                       |                                                                                                                                 | Corner basket            |                                   |
| CLASS                                                           | 0.5 UNTIL 3<br>3 UNTIL 6<br>6 UNTIL 30<br>30 UNTIL 120<br>120 UNTIL 400<br>400 UNTIL 1000<br>1000 UNTIL 2000<br>2000 UNTIL 4000 |                          |                                   |
| M (MIDDLE)                                                      | ±0.1<br>±0.1<br>±0.2<br>±0.3<br>±0.5<br>±0.8<br>±1.2<br>±2                                                                      |                          |                                   |
| PROJECTION:                                                     | GENERAL ANGLE: ±0,5°                                                                                                            | EAN: 4008913048405       | VERSION NAME: chrome              |
| DRAWN BY: MS                                                    | CHECKED BY:                                                                                                                     | GENERAL ROUGHNESS: 0,8 ✓ | ARTICLE NR.: 3048.3.03.46         |
| DATE: 26-10-2011                                                | STATUS: Production                                                                                                              | UNITS: mm                | PROJECT: 169-Boston corner basket |
| PRINT DATE: 9-7-2025                                            | INT.REV.NR.: 02                                                                                                                 | SCALE: 1:5               | DRAWING NR.: 169.02.00.TC         |
|                                                                 |                                                                                                                                 | FORMAT: A3               |                                   |
|                                                                 |                                                                                                                                 | SHEET: 1/3               |                                   |

The reproduction, distribution and utilization of this document as well as the communication of its contents to others without express authorization is prohibited. Offenders will be held liable for the payment of damages. All rights reserved in the event of the grant of a patent, utility model or design. Copyright reserved.