

FINAL DRAWING

REVISIONS				
REV.	DESCRIPTION	DATE	BY	APPROVED
-	See 130.02.00.TC	-	-	-

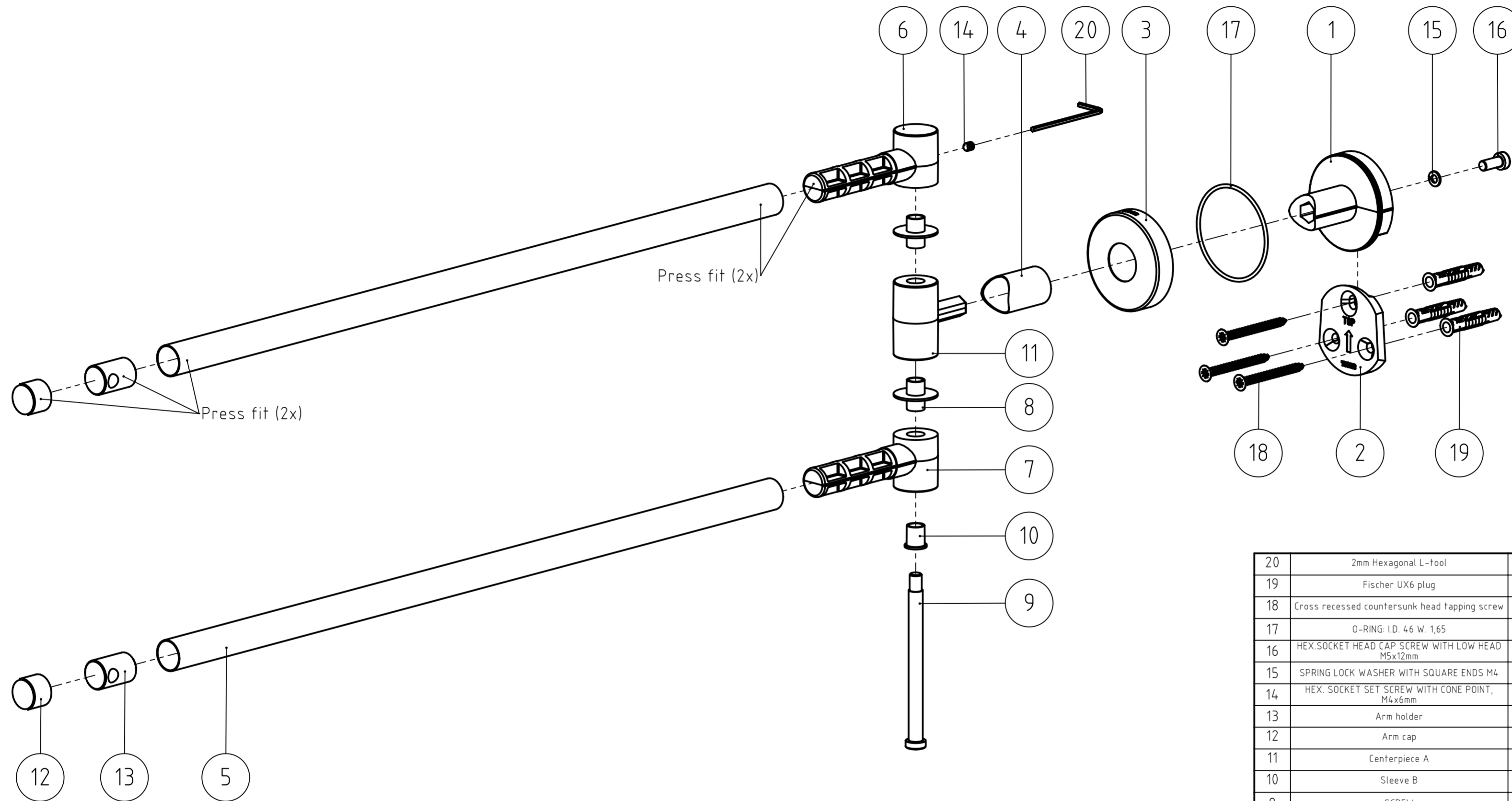

NR.	DESCRIPTION	QTY.	DRAW.NR.	MATERIAL	TREATMENT
20	2mm Hexagonal L-tool	1	DIN.911	Tool steel	-
19	Fischer UX6 plug	3	FIX.0028	-	-
18	Cross recessed countersunk head tapping screw	3	DIN.7982 CZ	Stainless steel A2	-
17	O-RING: I.D. 4.6 W. 1,65	1	BUY-IN	RUBBER, BLACK	Technical Smooth
16	HEX.SOCKET HEAD CAP SCREW WITH LOW HEAD M5x12mm	1	DIN.6912	Stainless steel A2	-
15	SPRING LOCK WASHER WITH SQUARE ENDS M4	1	DIN.127 B	STAINLESS STEEL A2	-
14	HEX. SOCKET SET SCREW WITH CONE POINT, M4x6mm	1	DIN.0914	Stainless steel A2	-
13	Arm holder	2	04.0.10.03	Zamac3	Chromium Plated
12	Arm cap	2	04.0.06.07	Stainless steel AISI 430	Powder coated, texture VDI 3400 ref.30 - RAL 9005 (Jet black)
11	Centerpiece A	1	04.0.06.05	Zamac3	Powder coated, texture VDI 3400 ref.30 - RAL 9005 (Jet black)
10	Sleeve B	1	130.02.11	PA 6 - transparent white RAL 9002	Technical Smooth
9	SCREW	1	130.02.10	STAINLESS STEEL A2	-
8	Sleeve A	2	130.02.09	PA 6 - Black RAL 9005, semi gloss	Technical Smooth
7	Lower arm holder	1	130.02.07	Zamac3	Powder coated, texture VDI 3400 ref.30 - RAL 9005 (Jet black)
6	Upper arm holder	1	130.02.06	Zamac3	Powder coated, texture VDI 3400 ref.30 - RAL 9005 (Jet black)
5	Arm	2	130.02.05	Stainless steel AISI 430	Powder coated, texture VDI 3400 ref.30 - RAL 9005 (Jet black)
4	Tube	1	130.02.04	Stainless steel AISI 430	Powder coated, texture VDI 3400 ref.30 - RAL 9005 (Jet black)
3	Cover	1	130.02.03	Stainless steel AISI 430	Powder coated, texture VDI 3400 ref.30 - RAL 9005 (Jet black)
2	Wall plate	1	130.02.02	Zamac3	Chromium Plated
1	Wall bracket	1	130.02.01	Zamac3	Chromium Plated

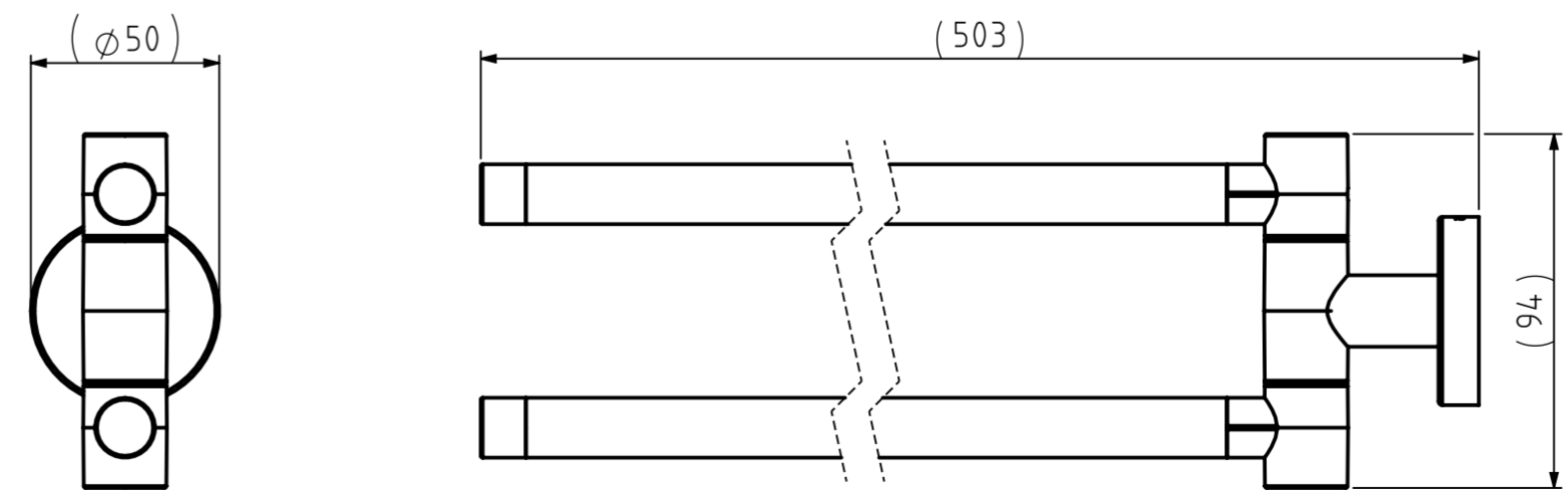

GENERAL DIMENSION UNLESS OTHERWISE STATED ACCORDING TO DIN 7168		DESCRIPTION:	
NOMINAL MEASUREMENTS (mm)			
CLASS	0.5 UNTIL 3	3 UNTIL 6	6 UNTIL 30
	3	6	30
	UNTIL 120	UNTIL 400	UNTIL 1000
	120	400	1000
	UNTIL 2000	UNTIL 4000	UNTIL 2000
	2000	4000	2000
M (MIDDLE)	±0.1	±0.1	±0.2
	±0.2	±0.3	±0.5
	±0.8	±1.2	±2
PROJECTION:	GENERAL ANGLE:	EAN:	VERSION NAME:
	±0,5°	4008913087428	black
DRAWN BY:	MS	GENERAL ROUGHNESS:	0,8
CHECKED BY:		PROJECT:	130-Boston
DATE:	9-10-2017	UNITS:	mm
STATUS:	Production	SCALE:	1:2
PRINT DATE:	25-9-2024	FORMAT:	A2
INT.REV.NR.:	0000	SHEET:	3/3
DRAWING NR:			130.02.00.TB
ARTICLE NR.:			3087.3.07.46



The reproduction, distribution and utilization of this document as well as the communication of its contents to others without express authorization is prohibited. Offenders will be held liable for the payment of damages. All rights reserved in the event of a patent, utility model or design. Copyright reserved.