

FINAL DRAWING

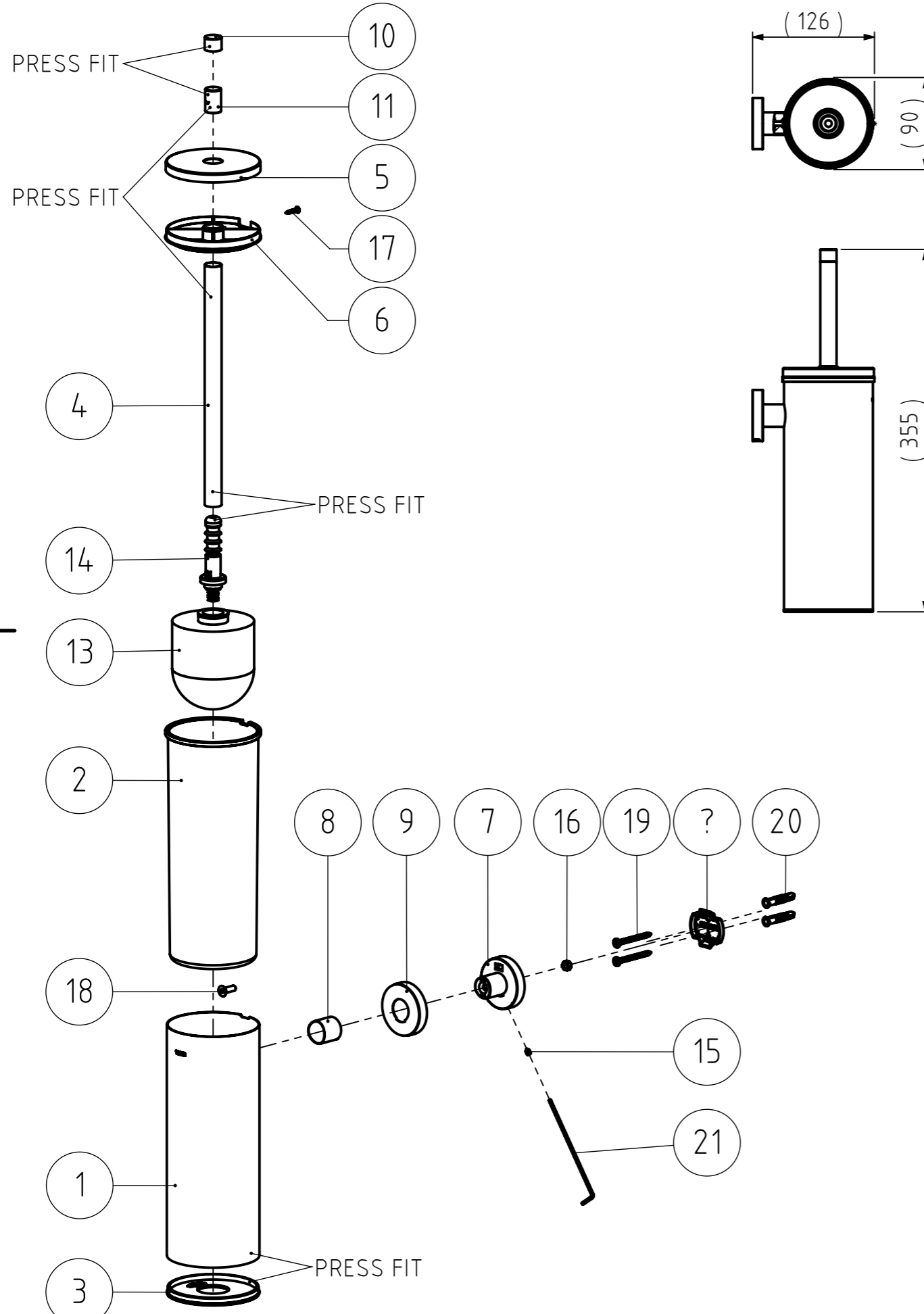

REVISIONS

REV.	DESCRIPTION	DATE	BY	APPROVED
-	See 130.07.00.TC	-	-	-

NR.	DESCRIPTION	QTY.	DRAW.NR.	MATERIAL	TREATMENT
21	2mm Hexagonal L-foot long arm ball end (extra long L=100mm)	1	DIN.911 L	Tool steel	-
20	Fischer UX6 plug	2	FIX.0028	-	-
19	Cross recessed pan head tapping screw st4,2x4,5mm	2	DIN.7981 CZ	Stainless steel A2	-
18	HEX. SOCKET COUNTERSUNK HEAD SCREW, M5x16mm	1	DIN.7991	Stainless steel A2	-
17	Cross recessed countersunk head tapping screw	1	DIN.7982 CZ	Stainless steel A2	-
16	SELF PREVAILING NUT, M5	1	DIN.0985	Stainless steel A2	-
15	HEX. SOCKET SET SCREW WITH CONE POINT, M4x6mm	1	DIN.0914	Stainless steel A2	-
14	Toilet brush connector	1	BUY.05.02	PP - Black RAL 9005	-
13	STANDARD TIGER BRUSH	1	099.01.02	various	-
12	Wallplate Type 1	1	226.03.02	Stainless steel AISI 304	Sand blasted
11	Arm holder	1	040.10.03	Zamac3	Chromium Plated
10	Arm cap	1	040.06.07	Stainless steel AISI 304	Brushed
9	Cover	1	130.07.10	Stainless steel AISI 304	Brushed
8	Tube	1	130.07.09	Stainless steel AISI 304	Brushed
7	Wall bracket	1	130.07.08	Zamac3	Chromium Plated
6	Inner cover	1	130.07.06	PP - Black RAL 9005, semi gloss	Texture VDI 3400 ref.30 (standard)
5	Brush cover	1	130.07.05	Stainless steel AISI 304	Brushed
4	Handle	1	130.07.04	Stainless steel AISI 304	Brushed
3	Bottom	1	130.07.03	PP - Black RAL 9005, semi gloss	Texture VDI 3400 ref.30 (standard)
2	Inner pot	1	130.07.02	PP - Black RAL 9005, semi gloss	Texture VDI 3400 ref.30 (standard)
1	Pot	1	130.07.01	Stainless steel AISI 304	Brushed

GENERAL DIMENSION UNLESS OTHERWISE STATED ACCORDING TO DIN 7168

CLASS	NOMINAL MEASUREMENTS (mm)							
	0.5 UNTIL 3	3 UNTIL 6	6 UNTIL 30	30 UNTIL 120	120 UNTIL 400	400 UNTIL 1000	1000 UNTIL 2000	2000 UNTIL 4000
M (MIDDLE)	±0.1	±0.1	±0.2	±0.3	±0.5	±0.8	±1.2	±2

DESCRIPTION: Toilet brush and holder

VERSION NAME: stainless steel ARTICLE NR.: 3099.3.09.46

PROJECT: 130-Boston

DRAWING NR.: 130.07.00.TS

GENERAL ROUGHNESS: 0,8 ✓

UNITS: mm

SCALE: 1:5

FORMAT: A3

SHEET: 2/3

DATE: 27-5-2009

PRINT DATE: 3-10-2024

INT.REV.NR.: 0000

STATUS: Production

DRAWN BY: MS

CHECKED BY: RS

Tiger Products b.v.
Winde 3, PO box 11
5660 AA Geldrop
The Netherlands

The reproduction, distribution and utilization of this document as well as the communication of its contents to others without express authorization is prohibited. Offenders will be held liable for the payment of damages. All rights reserved in the event of the grant of a patent, utility model or design. Copyright reserved.