

The reproduction, distribution and utilization of this document as well as the communication of its contents to others without express authorization is prohibited. Offenders will be held liable for the payment of damages. All rights reserved in the event of the grant of a patent, utility model or design. Copyright reserved.

1		2		3		4	
REVISIONS							
REV.	DESCRIPTION			DATE	BY	APPROVED	
1	Horizontal brush direction			4-7-2013	FVP	MS	

# FINAL DRAWING

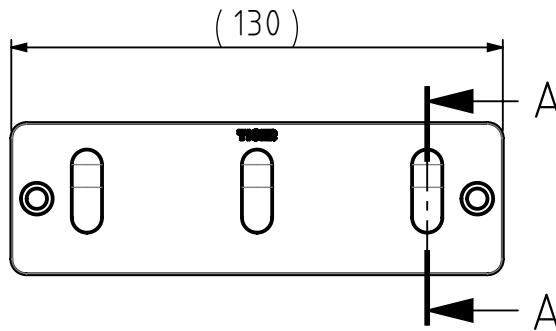
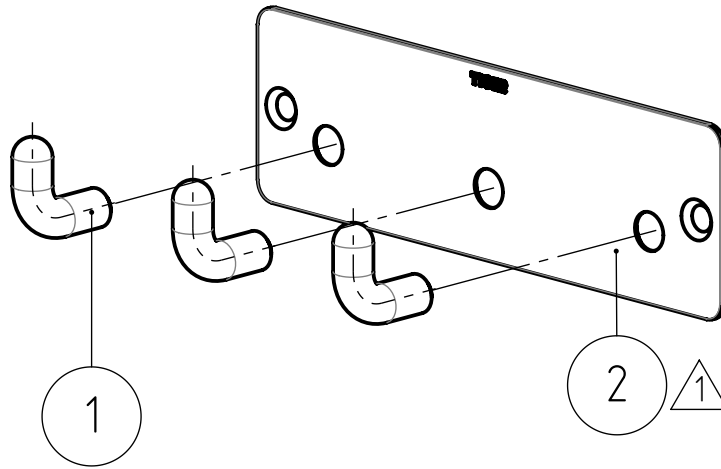

Connect by riveting (3x)

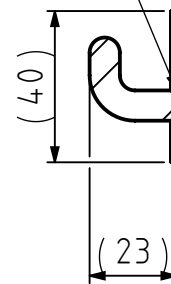

SECTION A-A  
SCALE 1 : 2

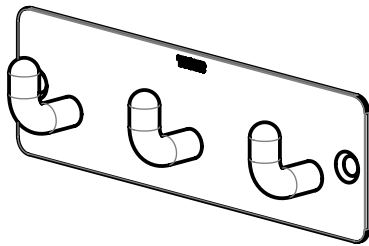

### REMARK:

- WELDS MUST BE GRINDED UNTIL THE REAR SIDE IS FLAT

2	WALL PLATE	1	178.07.01	STAINLESS STEEL 430	Brushed
1	Hook Pinky	3	178.06.02	Stainless steel 430	Brushed
ART.NR.	DESCRIPTION	QTY.	DRAW.NR.	MATERIAL	TREATMENT

GENERAL DIMENSION UNLESS OTHERWISE STATED ACCORDING TO DIN 7168									DESCRIPTION:  <b>RACK PINKY</b>
CLASS	NOMINAL MEASUREMENTS (mm)								
	0.5 UNTIL 3	3 UNTIL 6	6 UNTIL 30	30 UNTIL 120	120 UNTIL 400	400 UNTIL 1000	1000 UNTIL 2000	2000 UNTIL 4000	
M (MIDDLE)	±0.1	±0.1	±0.2	±0.3	±0.5	±0.8	±1.2	±2	

PROJECTION: 	GENERAL ANGLE: ±0,5°	VERSION NAME: Stainless steel	ARTICLE NR. (packed product): 11033.3.09.41 (for packaging information see GDS)
DRAWN BY: MS	CHECKED BY: w.w.	GENERAL ROUGHNESS:	PROJECT: 178-HOOKS
DATE: 12-8-2012	UNITS: mm	SCALE: 1:2	DRAWING NR: 178.07.00.TS
STATUS: Production	FORMAT: A4	SHEET: 1/1	<b>TIGER</b> Tiger Products b.v. Winde 3, PO box 11 5660 AA Geldrop The Netherlands
PRINT DATE: 7-4-2026			