

FINAL DRAWING

REVISIONS				
REV.	DESCRIPTION	DATE	BY	APPROVED
-	See 207.02.00.TS	-	-	-

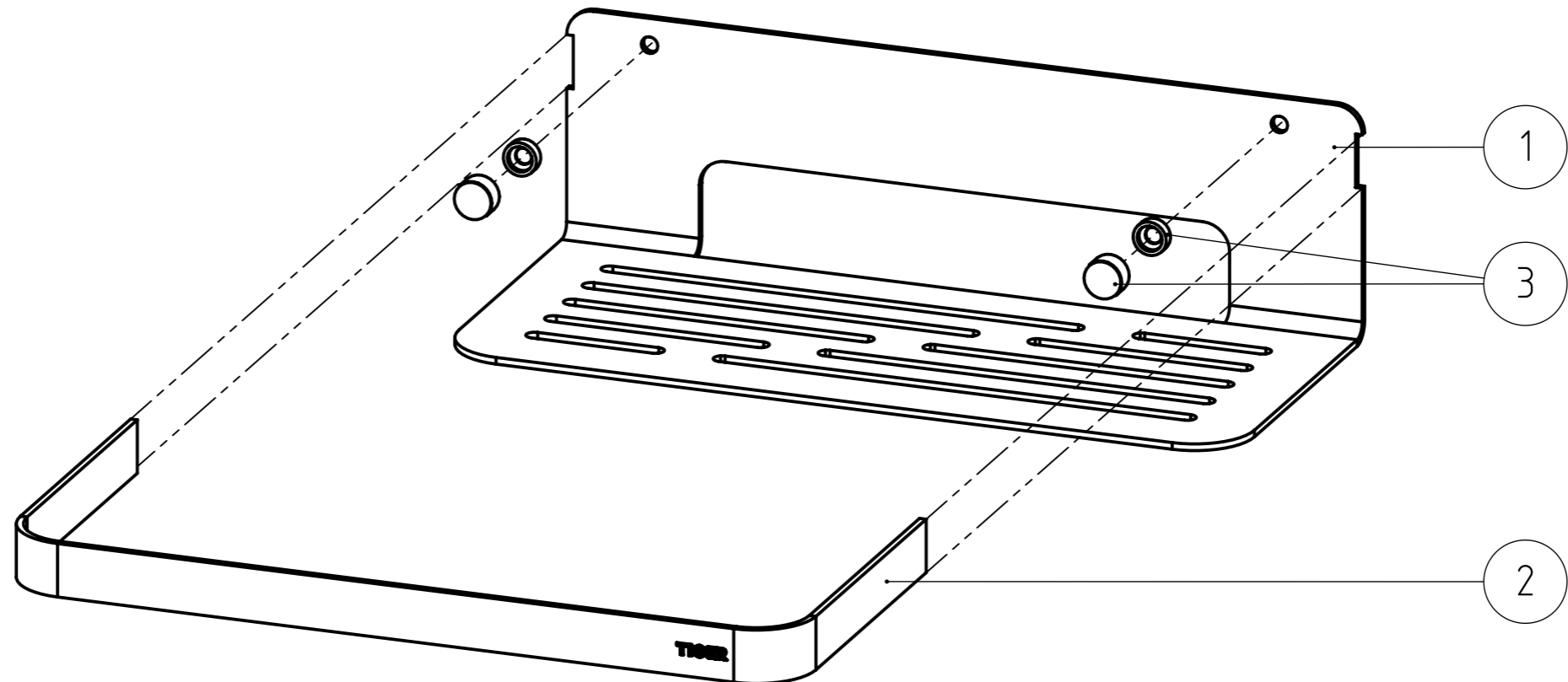

Smooth welds (grinded)

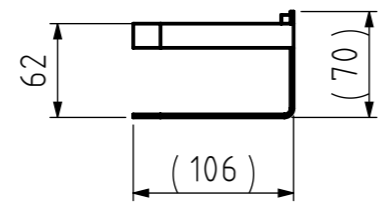
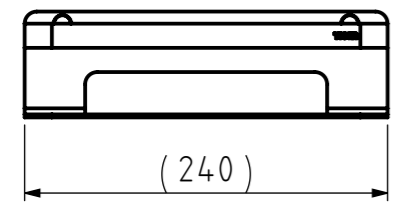
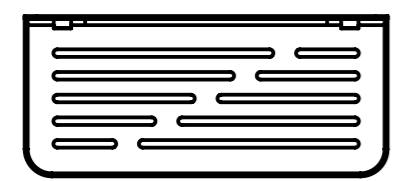
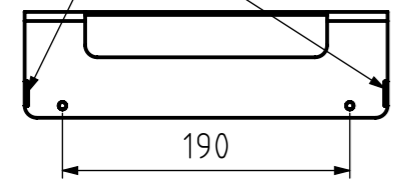

Remarks:
 - Only weld on the back side
 - Add '9953.1.80.50 - Fixationset Info 4,5 x 45 mm RVS A2 (Vigo-style)'

NR.	DESCRIPTION	QTY.	DRAW.NR.	MATERIAL	TREATMENT
3	Screw cap assembly (11,5x6,2mm)	2	BUY.15.00	-	Powder coated, texture VDI 3400 ref.30 - RAL 9003 (signal white)
2	Strip	1	207.02.02	Stainless steel AISI 430	Powder coated, texture VDI 3400 ref.30 - RAL 9003 (Signal white)
1	Basket	1	207.02.01	Stainless steel AISI 430	Powder coated, texture VDI 3400 ref.30 - RAL 9003 (Signal white)

GENERAL DIMENSION UNLESS OTHERWISE STATED ACCORDING TO DIN 7168							DESCRIPTION:	
CLASS	NOMINAL MEASUREMENTS (mm)						Basket	
	0.5 UNTIL 3	3 UNTIL 6	6 UNTIL 30	30 UNTIL 120	120 UNTIL 400	400 UNTIL 1000		
M (MIDDLE)	±0.1	±0.1	±0.2	±0.3	±0.5	±0.8	±1.2	±2
PROJECTION:	GENERAL ANGLE:		EAN:		VERSION NAME:			ARTICLE NR.:
	±0,5°		8720553003175		white			800130
DRAWN BY:	MS		GENERAL ROUGHNESS:		PROJECT:			TIGER Tiger Nederland b.v. Winde 3, PO box 11 5660 AA Geldrop The Netherlands
CHECKED BY:	FVP		0,8/✓		207-Caddy			
DATE:	30-10-2013		UNITS:		DRAWING NR.:			
STATUS:	Production		mm		207.02.00.TW			
PRINT DATE:	8-4-2025		SCALE:		FORMAT:			
INT.REV.NR.:	06		1:5		SHEET:			
			A3		4/4			

The reproduction, distribution and utilization of this document as well as the communication of its contents to others without express authorization is prohibited. Offenders will be held liable for the payment of damages. All rights reserved in the event of the grant of a patent, utility model or design. Copyright reserved.