

Suction cup U10 Silicone

Article number: 3150117S

- Suitable for objects with flat or slightly curved surfaces.
- Also used for concave objects.



Technical data

Description	Unit	Value
Suction cup shape	-	Universal
Application	-	Glass handling
Suction cup design	-	Round
Characteristics	-	Glass handling
Material	-	Silicone (SIL)
Weight, min.	g	0.65
Suction cup model	-	U
Volume	cm ³	0.18
Height	mm	10.5
Outer diameter, min.	mm	11
Fitting size	-	None
Fitting option	-	None
Fitting style	-	None
Fitting type	-	None
Suction cup model	-	U10
Movement, vertical max.	mm	0.5
Curve radius, min.	mm	8

Performance - Lifting forces

U10	Vertical (N)	Parallel (N)
20 -kPa	1.5	1.6
60 -kPa	4.4	3.5
90 -kPa	6.9	4.8

Material

Name	Silicone, SIL 50° Shore A
Colour	Red
Temperature, min. °C	-40
Temperature max. °C	200
Hardness °Shore A	50

Material resistance

Alcohol	Good
Concentrated acids	Poor
Ethanol	n/a
Hydrolysis	Fair
Methanol	n/a
Oil	Poor
Oxidation	Excellent
Petrol	Poor
Wear resistance	Good

Water and ozone

Excellent

Name

Silicone, SIL 50° Shore A

Dimensional drawings

Red

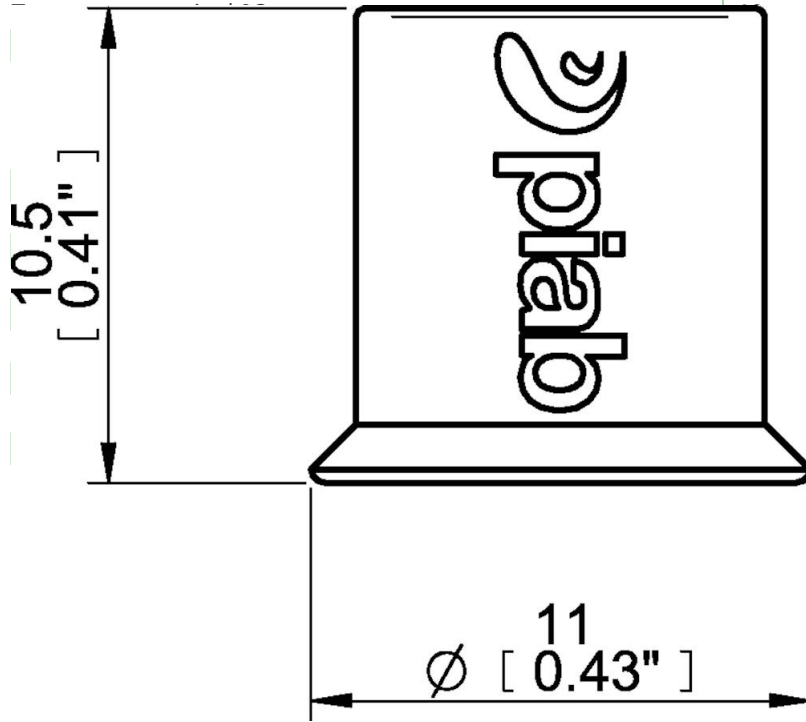

nt

nt

Values specified in this data sheet are tested at (unless otherwise stated):

- Room temperature (20°C [68°F] ± 3°C [5.5°F]).
- Standard atmosphere (101.3 [29.9 inHg] ± 1.0 kPa [0.3 inHg]).
- Relative humidity 20-70%.
- Compressed air quality, DIN ISO 8573-1 class 4.

Accessories

3107030 | Fitting M5 male, 10-15