

VGS4005, SX12 Ø 1/4"

Article number: 0231209



- Light weight vacuum gripper ejector with plastic housing
- VGS4005 with SX12 or SX42 cartridge without flap valves, a COAX® chosen for very harsh environments, combining high dust and high humidity levels
- Optimal in applications when less vacuum depth is needed, such as bag/pouch handling etc
- Reduced noise level with Integrated silencer
- VGS4005 is compatible with any suction cup with G3/8" male fitting from Piab's assortment.

Technical data

Description	Unit	Value
Material	-	CuZn, Nitrile (NBR), PA, POM, PPM, Polyurethane (PU), SS
Load, vertical, max.	N	70
Temperature, max.	°C	80
Temperature, min.	°C	-10
Weight, min.	g	70
Feed pressure, max.	MPa	0.7
Noise level, max.	dBA	75
Noise level, min.	dBA	63

Performance

Feed pressure MPa	Air consumption NI/s	Vacuum flow (NI/s) at different vacuum levels (-kPa)													Max vacuum kPa		
		0	10	20	30	40	50	60	70	75	80	90	95	99			
0.5	0.72	1.22	1.03	0.78	0.52	0.27	0	0	0	0	0	0	0	0	0	0	≥47
0.6	0.84	1.34	1.15	0.96	0.7	0.45	0.17	0	0	0	0	0	0	0	0	0	≥55

Feed pressure MPa	Air consumption NI/s	Evacuation time (s/l) to reach different vacuum levels (-kPa)													Max vacuum kPa		
		10	20	30	40	50	60	70	80	90	95	99	99.5	100.3			
0.5	0.72	0.089	0.199	0.353	0.606	0	0	0	0	0	0	0	0	0	0	0	≥47
0.6	0.84	0.08	0.175	0.296	0.47	0.792	0	0	0	0	0	0	0	0	0	0	≥55

Dimensional drawings

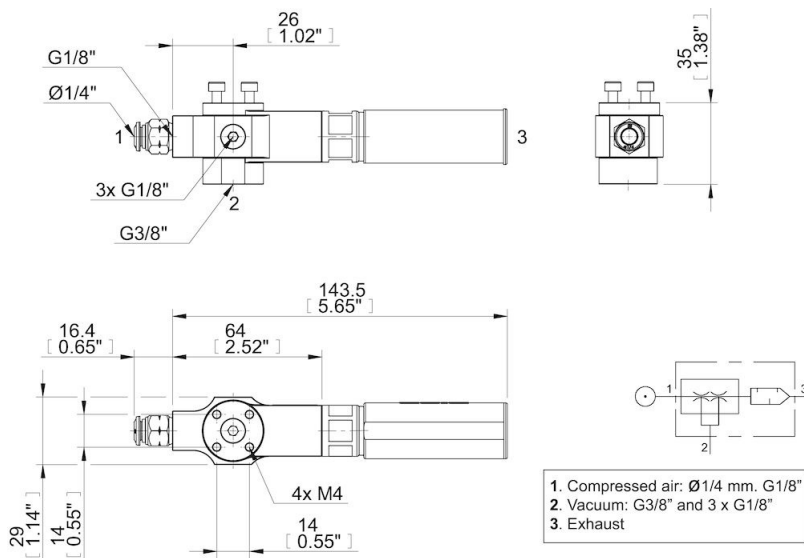

Values specified in this data sheet are tested at (unless otherwise stated):

- Room temperature (20°C [68°F] ± 3°C [5.5°F]).
- Standard atmosphere (101.3 [29.9 inHg] ± 1.0 kPa [0.3 inHg]).
- Compressed air quality, DIN ISO 8573-1 class 4.