

Suction cup BF80P Polyurethane 60, G3/8" male with mesh filter

Article number: 0107327



- Suitable for uneven surfaces.
- In the two-coloured suction cup the bellows and the sealing lip are of different hardnesses, which makes the suction cup strong and stable and, at the same time, soft and flexible.
- DURAFLEX® suction cups manufactured in a specially developed material that features the elasticity of rubber and wear resistance of polyurethane.
- The material of the DURAFLEX® is mark free.

Technical data

Description	Unit	Value
Suction cup shape	-	Bellows
Application	-	Dry sheet metal, Glass handling, Mark Free
Suction cup design	-	Round
Characteristics	-	Dry sheet metal, Glass handling, Mark free
Material	-	Polyurethane (PU)
Weight, min.	g	53
Suction cup model	-	BF-P
Volume	cm ³	40
Height	mm	46.5
Outer diameter, min.	mm	83.1
Outer diameter, actuated	mm	61.1
Fitting size	-	3/8"
Fitting option	-	Filter mesh
Fitting style	-	Male
Fitting type	-	G-thread
Suction cup model	-	BF80P PU60
Movement, vertical max.	mm	15.6
Curve radius, min.	mm	50

Performance - Lifting forces

BF80P PU60	Vertical (N)	Parallel (N)
20 -kPa	98	68
60 -kPa	225	127
90 -kPa	294	166

Material

Name	Polyurethane (PU60)
Colour	Green transparent
Temperature, min. °C	10
Temperature max. °C	50
Hardness °Shore A	60

Material resistance

Alcohol	n/a
Concentrated acids	Fair
Ethanol	Fair
Hydrolysis	Fair
Methanol	Poor
Oil	Excellent
Oxidation	Poor
Petrol	Fair
Wear resistance	Excellent
Weather and ozone	Excellent

Dimensional drawings

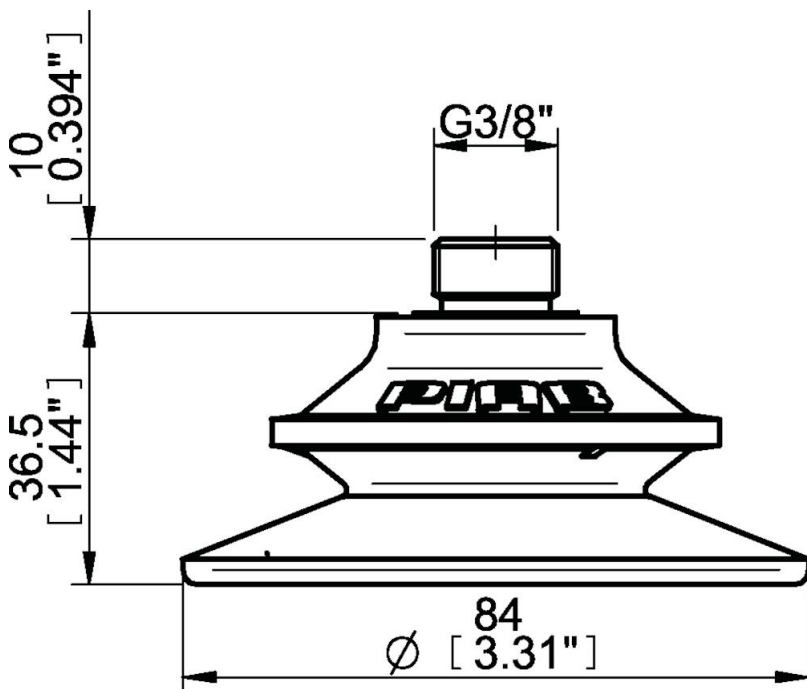

Values specified in this data sheet are tested at (unless otherwise stated):

- Room temperature (20°C [68°F] ± 3°C [5.5°F]).
- Standard atmosphere (101.3 [29.9 inHg] ± 1.0 kPa [0.3 inHg]).
- Relative humidity 20-70%.
- Compressed air quality, DIN ISO 8573-1 class 4.