

# COAX® cartridge MINI Xi10-3

Article number: 0120286



- Three-stage COAX® cartridge – MINI.
- High vacuum flow at deep vacuum levels to 94 - kPa.
- Quick response time when deep vacuum is needed.
- Suitable for handling sealed objects with high pick-up speed.
- Large vacuum flow in relation to energy consumption

## Technical data

Description	Unit	Value
Material	-	Al, Nitrile (NBR), PA, SS
Temperature, max.	°C	80
Temperature, min.	°C	-10
Weight, max.	g	12.5
Weight, min.	g	4.7
Feed pressure, max.	MPa	0.7

## Performance

Feed pressure MPa	Air consumption Nl/s	Vacuum flow (Nl/s) at different vacuum levels (-kPa)												Max vacuum kPa	
		0	10	20	30	40	50	60	70	75	80	90	95		99
0.45	0.42	1.39	0.64	0.46	0.28	0.19	0.15	0.11	0.07	0	0.043	0.003	0	0	≥92
0.5	0.46	1.43	0.7	0.5	0.33	0.19	0.15	0.11	0.07	0	0.045	0.011	0	0	≥94
0.6	0.54	1.45	0.79	0.53	0.42	0.3	0.16	0.11	0.08	0	0.041	0.01	0	0	≥93

Feed pressure MPa	Air consumption Nl/s	Evacuation time (s/l) to reach different vacuum levels (-kPa)												Max vacuum kPa	
		10	20	30	40	50	60	70	80	90	95	99	99.5		100.3
0.45	0.42	0.1	0.28	0.55	1	1.5	2.2	3.4	5.2	9.5	0	0	0	0	≥92
0.5	0.46	0.09	0.26	0.5	0.9	1.5	2.2	3.4	5.2	8.8	0	0	0	0	≥94
0.6	0.54	0.09	0.24	0.45	0.7	1.2	1.9	3	4.7	8.6	0	0	0	0	≥93

Feed pressure MPa	Air consumption Nl/s	Blow flow (Nl/s) at different pressure levels (-kPa)														Max pressure kPa	
		0	10	20	30	40	50	60	70	80	90	100	110	120	130		140
0.6	0.54	1.8	1.3	1.1	0.98	0.85	0.84	0.79	0.71	0.61	0	0	0	0	0	0	≥93

## Dimensional drawings

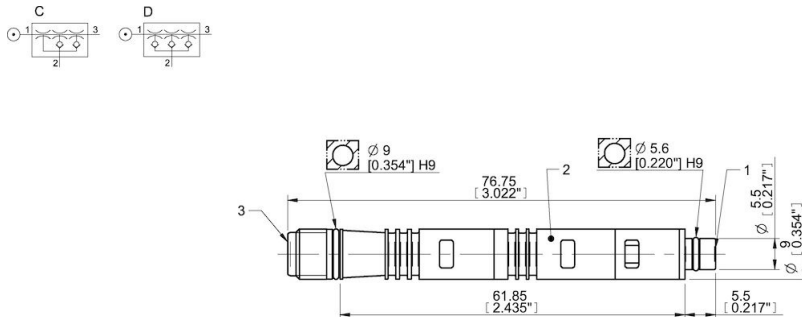

Values specified in this data sheet are tested at (unless otherwise stated):

- Room temperature (20°C [68°F] ± 3°C [5.5°F]).
- Standard atmosphere (101.3 [29.9 inHg] ± 1.0 kPa [0.3 inHg]).
- Compressed air quality, DIN ISO 8573-1 class 4.

