

# Suction cup B-BL30-2 Silicone, 1/2" NPT male composite detectable, FCM

Article number: 0207098

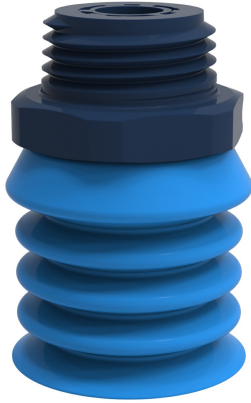

- The silicone material complies with FDA 21 CFR 177.2600 and EU 1935/2004.
- Long lasting high-end silicone material
- A low percentage metal additive (Fe) is mixed with the rubber material to make it detectable.
- Suitable for bakeries for use with handling seeded product.
- Suitable for level adjustment.
- Available with male threaded food grade, detectable plastic fittings or acid proof stainless steel fittings. The fittings are separable.
- Additional fitting option – retainer clip for standard belts used for bread de-panner
- Easy to clean with hygienic design. No dust/dirt pockets.
- Low vacuum level needed to collapse bellows. Reduces risk for damaging the handled bakery product

## Technical data

| Description              | Unit            | Value   |
|--------------------------|-----------------|---|
| Suction cup shape        | -               | Multibellows                                  |
| Application              | -               | Food contact materials (FDA & EU), detectable |
| Suction cup design       | -               | Round   |
| Characteristics          | -               | Food contact materials (FDA & EU), detectable |
| Material                 | -               | Silicone (SIL)                                |
| Load, torque, max.       | Nm              | 13  |
| Weight, min.             | g               | 10.5  |
| Suction cup model        | -               | B-BL  |
| Volume                   | cm <sup>3</sup> | 11  |
| Height                   | mm              | 34  |
| Outer diameter, min.     | mm              | 30  |
| Outer diameter, actuated | mm              | 30.5  |
| Fitting size             | -               | 1/2"  |
| Fitting option           | -               | None  |
| Fitting style            | -               | Male  |
| Fitting type             | -               | NPT-thread                                    |
| Tightening torque, max.  | Nm              | 13  |
| Material                 | -               | Composite                                     |
| Suction cup model        | -               | B-BL30-2 FCM, detectable                      |
| Movement, vertical max.  | mm              | 16.8  |
| Curve radius, min.       | mm              | 10.8  |

## Performance - Lifting forces

| B-BL30-2 FCM, detectable | Vertical (N) | Parallel (N) |
|--------------------------|--------------|--------------|
| 10 -kPa                  | 4.4          | 3            |
| 20 -kPa                  | 7.4          | 4.4          |
| 40 -kPa                  | 12.3         | 8.3          |

## Material

|                        |                               |
|------------------------|-------------------------------|
| Name                   | Silicone (SIL detectable FCM) |
| Colour                 | Blue                          |
| Temperature, min.   °C | -40                           |
| Temperature max.   °C  | 200                           |
| Hardness   °Shore A    | 40                            |

## Material resistance

|                    |           |
|--------------------|-----------|
| Alcohol            | Good      |
| Concentrated acids | Poor      |
| Ethanol            | n/a       |
| Hydrolysis         | Fair      |
| Methanol           | n/a       |
| Oil                | Poor      |
| Oxidation          | Excellent |
| Petrol             | Poor      |
| Wear resistance    | Good      |
| Weather and ozone  | Excellent |

## Dimensional drawings

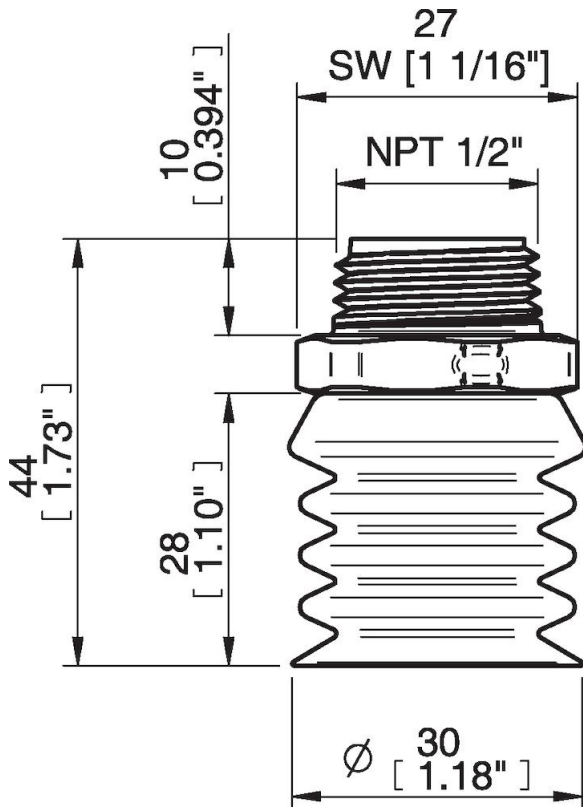

## Values specified in this data sheet are tested at (unless otherwise stated):

- Room temperature (20°C [68°F] ± 3°C [5.5°F]).
- Standard atmosphere (101.3 [29.9 inHg] ± 1.0 kPa [0.3 inHg]).
- Relative humidity 20-70%.
- Compressed air quality, DIN ISO 8573-1 class 4.

## Accessories

- 0121660 | Retainer clip Ø9, composite, B-BL
- 0207181 | Fitting G3/8" Male, SS, B-BL
- 0207182 | Fitting 3/8" NPT Male, SS, B-BL
- 0207183 | Fitting G1/2" Male, SS, B-BL
- 0207184 | Fitting 1/2" NPT Male, SS, B-BL
- 0207190 | Fitting G3/8" Male, composite, B-BL
- 0207191 | Fitting 3/8" NPT Male, composite, B-BL
- 0207192 | Fitting G1/2" Male, composite, B-BL
- 0207193 | Fitting 1/2" NPT Male, composite, B-BL

## Spare parts

- 0206373 | Suction cup B-BL30-2 Silicone, detectable, FCM

**Spare parts**  
0207193 | Fitting 1/2" NPT Male, composite, B-BL  
0206373 | Suction cup B-BL30-2 Silicone, detectable, FCM  
0207193 | Fitting 1/2" NPT Male, composite, B-BL