

Suction cup BL50-4 Silicone FCM, 1/2" NPT male

Article number: 9909650



- The silicone material complies with FDA 21 CFR 177.2600 & EU 1935/2004
- Good sealing properties
- Suitable for bags with fragile content e.g. snacks and cookies and lifting frozen food
- Suitable for level compensation
- High flow fitting

Technical data

Description	Unit	Value
Suction cup shape	-	Multibellows
Application	-	Bag handling, Food contact materials (FDA & EU), non-detectable
Suction cup design	-	Round
Characteristics	-	Bag handling, Food contact materials (FDA & EU), non-detectable
Material	-	Silicone (SIL)
Weight, min.	g	25
Suction cup model	-	BL-4
Volume	cm ³	35
Height	mm	75
Outer diameter, min.	mm	50.3
Fitting size	-	1/2"
Fitting option	-	None
Fitting style	-	Male
Fitting type	-	NPT-thread
Suction cup model	-	BL50-4
Movement, vertical max.	mm	22
Curve radius, min.	mm	30

Performance - Lifting forces

BL50-4	Vertical (N)	Parallel (N)
20 -kPa	8	8.4
60 -kPa	25	16.8

Material

Name	Silicone FDA 40° Shore A
Colour	Transparent
Temperature, min. °C	-40
Temperature max. °C	200
Hardness °Shore A	40

Material resistance

Alcohol	Good
Concentrated acids	Poor
Ethanol	n/a
Hydrolysis	Fair
Methanol	n/a
Oil	Poor
Oxidation	Excellent
Petrol	Poor
Wear resistance	Good
Weather and ozone	Excellent

Dimensional drawings

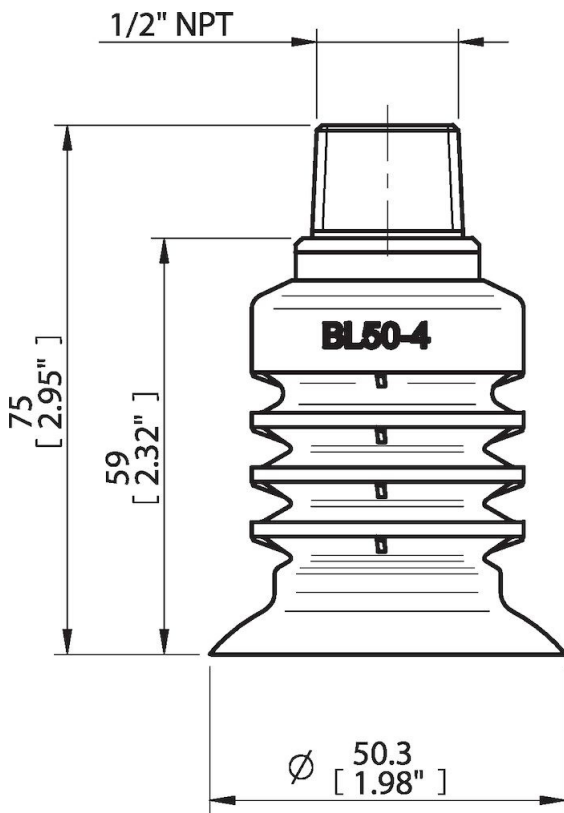

Values specified in this data sheet are tested at (unless otherwise stated):

- Room temperature (20°C [68°F] ± 3°C [5.5°F]).
- Standard atmosphere (101.3 [29.9 inHg] ± 1.0 kPa [0.3 inHg]).
- Relative humidity 20-70%.
- Compressed air quality, DIN ISO 8573-1 class 4.

Accessories

0113117 | Fitting G1/2" male, bag

Spare parts

0113140 | Fitting 1/2" NPT male, bag

0200238 | Suction cup BL50-4 Silicone FCM