

COAX® in piGRIP® Ti

Article number: 0200346

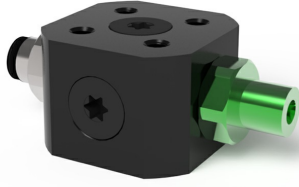

- Fully decentralized vacuum unit based on patented COAX® technology.
- Quickest response time and very high energy efficiency.
- Easy system dimensioning – small risk for mistakes.
- Available with a variation of two-stage COAX® MICRO cartridges.
- Suitable for high vacuum flow.
- Suitable for extra capacity/dirt tolerance.

Technical data

Description	Unit	Value
Material	-	Al, CuZn, Nitrile (NBR), PA
Temperature, max.	°C	80
Temperature, min.	°C	-10
Weight, min.	g	45
Feed pressure, max.	MPa	0.7
Noise level, max.	dBA	61
Noise level, min.	dBA	55

Performance

Feed pressure MPa	Air consumption NI/s	Vacuum flow (NI/s) at different vacuum levels (-kPa)												Max vacuum kPa	
		0	10	20	30	40	50	60	70	80	90	95	99		
0.45	0.29	0.35	0.31	0.25	0.18	0.11	0.08	0.06	0.03	0	0.007	0	0	0	≥84
0.6	0.37	0.34	0.3	0.26	0.21	0.16	0.1	0.048	0.023	0	0	0	0	0	≥79

Feed pressure MPa	Air consumption NI/s	Evacuation time (s/l) to reach different vacuum levels (-kPa)												Max vacuum kPa	
		10	20	30	40	50	60	70	80	90	95	99	99.5		100.3
0.45	0.29	0.3	0.66	1.12	1.8	2.85	4.35	6.55	11.5	0	0	0	0	0	≥84
0.6	0.37	0.31	0.67	1.089	1.63	2.39	3.7	6.54	0	0	0	0	0	0	≥79

Dimensional drawings

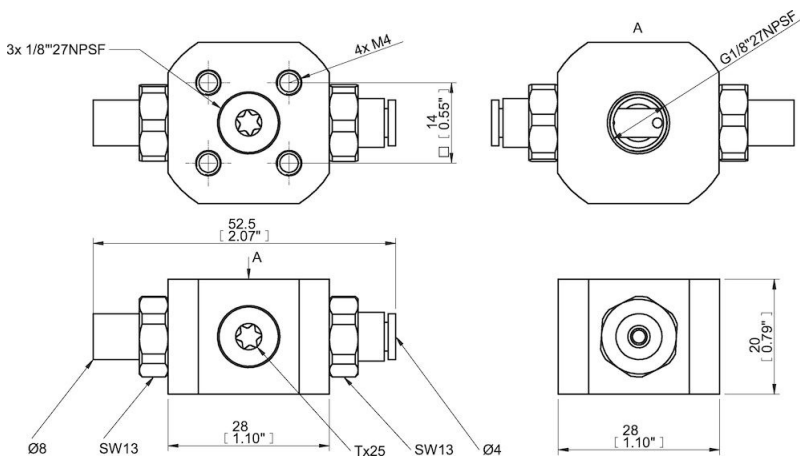

Values specified in this data sheet are tested at (unless otherwise stated):

- Room temperature (20°C [68°F] ± 3°C [5.5°F]).
- Standard atmosphere (101.3 [29.9 inHg] ± 1.0 kPa [0.3 inHg]).
- Compressed air quality, DIN ISO 8573-1 class 4.

Accessories

- 0106915 | Mounting kit 4xM4 VGS3010
- 0106927 | Mounting kit M8/16 VGS3010
- 0106949 | Mounting kit M8/27 04 VGS3010

Accessories 0108488 | Mounting kit M6/22 07 top VGS3010

0106915 | Mounting kit 4xM4 VGS3010

0106927 | Mounting kit M8/16 VGS3010

0106949 | Mounting kit M8/27 04 VGS3010

0108488 | Mounting kit M6/22 07 top VGS3010