

piSAVE® sense Multiple port fitting 02/60 (yellow)

Article number: 0202396



- Vacuum check valves which allows a few suction cups to miss the object(s) and still maintain enough vacuum level in the system with quick response and release times.
- The vacuum check valves shall be used in a centralized vacuum system, one for each suction cup.
- Designing with vacuum check valves will require a smaller vacuum pump and save energy.
- Also suitable for objects with surface leakage around the lip of the suction cup.
- Available in four sizes with different flow performance/characteristics to suit different degree of leakage on handled material and different size of cups.
- The valves are supplied separately for integration or mounted in an AI-fitting with female and male threaded connections to facilitate installation.

Technical data

Description	Unit	Value
Material	-	Al, HNBR, Nitrile (NBR), Thermoplastic Polyurethane (TPE-U)
Temperature, max.	°C	80
Temperature, min.	°C	-20
Weight, min.	g	20.7
Pump flow/cup minimum	l/s	0,02 (@ 45 -kPa)
Pump flow/cup to close valve	l/s	0,21 (@ 3 -kPa)
Valve colour	-	Yellow

Dimensional drawings

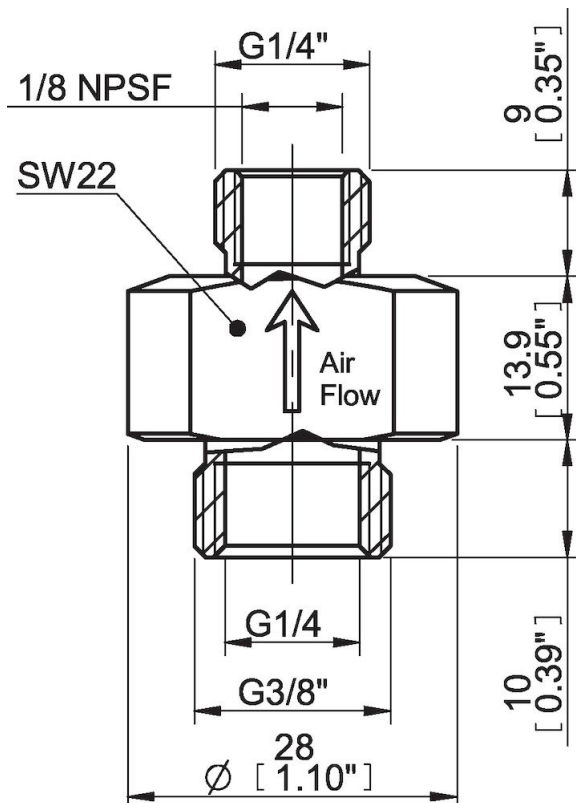

Accessories

0202589 | piSAVE® sense Assembly tool 16mm