

COAX® cartridge MINI Xi10-2, holding cap, extra non-return valve

Article number: 0120300



- Two-stage COAX® cartridge - MINI - with small mounting dimensions.
- High vacuum flow at deep vacuum levels to 94 – kPa.
- Large vacuum flow in relation to energy consumption.
- Quick response time when deep vacuum is needed.
- Good for handling sealed materials.

Technical data

Description	Unit	Value
Material	-	Al, Nitrile (NBR), PA, SS
Temperature, max.	°C	80
Temperature, min.	°C	-10
Weight, max.	g	9.7
Weight, min.	g	2.6
Feed pressure, max.	MPa	0.7

Performance

Feed pressure MPa	Air consumption Nl/s	Vacuum flow (Nl/s) at different vacuum levels (-kPa)												Max vacuum kPa	
		0	10	20	30	40	50	60	70	75	80	90	95		99
0.45	0.42	0.75	0.61	0.45	0.28	0.19	0.15	0.11	0.07	0	0.043	0.003	0	0	≥92
0.5	0.46	0.75	0.63	0.49	0.33	0.19	0.15	0.11	0.07	0	0.045	0.011	0	0	≥94
0.6	0.54	0.74	0.63	0.53	0.42	0.3	0.16	0.11	0.08	0	0.041	0.01	0	0	≥93

Feed pressure MPa	Air consumption Nl/s	Evacuation time (s/l) to reach different vacuum levels (-kPa)											Max vacuum kPa		
		10	20	30	40	50	60	70	80	90	95	99		99.5	100.3
0.45	0.42	0.15	0.3	0.6	1.1	1.6	2.3	3.5	5.3	9.6	0	0	0	0	≥92
0.5	0.46	0.14	0.3	0.6	1	1.6	2.3	3.5	5.3	8.9	0	0	0	0	≥94
0.6	0.54	0.15	0.3	0.5	0.8	1.3	2	3.1	4.8	8.7	0	0	0	0	≥93

Feed pressure MPa	Air consumption Nl/s	Blow flow (Nl/s) at different pressure levels (-kPa)													Max pressure kPa		
		0	10	20	30	40	50	60	70	80	90	100	110	120		130	140
0.6	0.54	1.2	1.2	1.1	0.98	0.85	0.84	0.79	0.71	0.61	0	0	0	0	0	0	≥93

Dimensional drawings

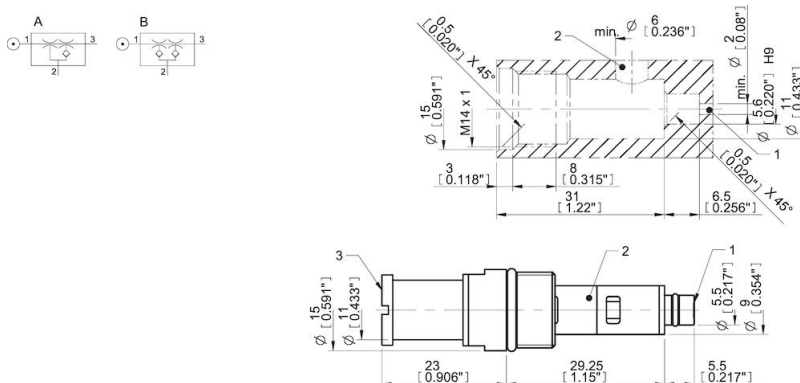

Values specified in this data sheet are tested at (unless otherwise stated):

- Room temperature (20°C [68°F] ± 3°C [5.5°F]).
- Standard atmosphere (101.3 [29.9 inHg] ± 1.0 kPa [0.3 inHg]).
- Compressed air quality, DIN ISO 8573-1 class 4.

Accessories

0111977 | Silencer COAX® MINI