

Suction cup B15-2 Silicone FCM, M5 male

Article number: 9909607



- The silicone material complies with FDA 21 CFR 177.2600 & EU 1935/2004.
- Lifting movement to separate small and thin objects.
- Only lightweight objects should be handled when the lifting force is parallel to the surface.
- Suitable for level adjustment.

Technical data

Description	Unit	Value
Suction cup shape	-	Bellows
Application	-	Food contact materials (FDA & EU), non-detectable
Suction cup design	-	Round
Characteristics	-	Food contact materials (FDA & EU), non-detectable
Material	-	Silicone (SIL)
Weight, min.	g	1.5
Suction cup model	-	B
Volume	cm ³	1.1
Height	mm	28.3
Outer diameter, min.	mm	15.7
Outer diameter, actuated	mm	18.5
Fitting size	-	None
Fitting option	-	None
Fitting style	-	Male
Fitting type	-	M-thread
Suction cup model	-	B15-2
Movement, vertical max.	mm	6.7
Curve radius, min.	mm	5

Performance - Lifting forces

B15-2	Vertical (N)	Parallel (N)
20 -kPa	2.9	1.7
60 -kPa	5.9	3.2
90 -kPa	8.9	3.8

Material

Name	Silicone (SIL FDA) 50° Shore
Colour	Transparent
Temperature, min. °C	-40
Temperature max. °C	200
Hardness °Shore A	50

Material resistance

Alcohol	Good
Concentrated acids	Poor
Ethanol	n/a
Hydrolysis	Fair
Methanol	n/a
Oil	Poor
Oxidation	Excellent
Petrol	Poor
Wear resistance	Good
Weather and ozone	Excellent

Dimensional drawings

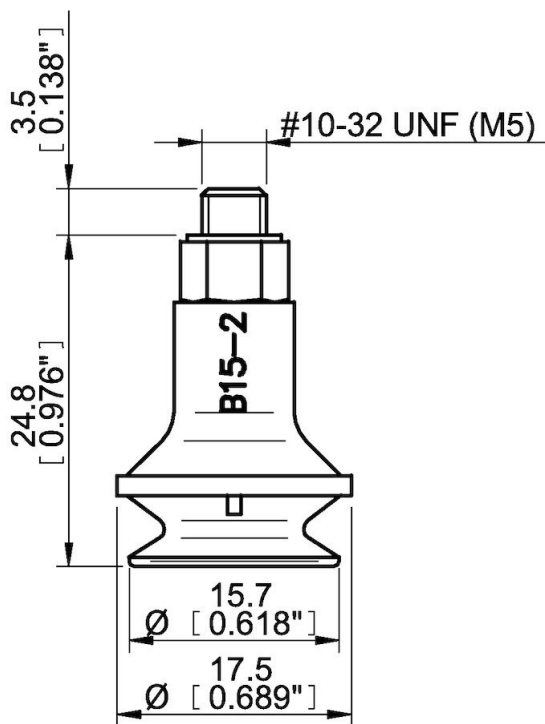

Values specified in this data sheet are tested at (unless otherwise stated):

- Room temperature (20°C [68°F] ± 3°C [5.5°F]).
- Standard atmosphere (101.3 [29.9 inHg] ± 1.0 kPa [0.3 inHg]).
- Relative humidity 20-70%.
- Compressed air quality, DIN ISO 8573-1 class 4.

Spare parts

- 0200271 | Suction cup B15-2 Silicone FCM
- 3107030 | Fitting M5 male, 10-15