

# Suction cup B15-2 HNBR

Article number: 0128693



- Suitable for level adjustment.
- Lifting movement to separate small and thin objects.
- Only lightweight objects should be handled when the lifting force is parallel to the surface.

## Technical data

Description	Unit	Value
Suction cup shape	-	Bellows
Application	-	Dry sheet metal, Plastic injection molded parts, Glass handling, High/low temp cup (plastic), Mark Free
Suction cup design	-	Round
Characteristics	-	Dry sheet metal, Plastic injection molded parts, Glass handling, High/low temp cup (plastic), Mark free
Material	-	HNBR
Weight, min.	g	1.5
Suction cup model	-	B
Volume	cm <sup>3</sup>	1.1
Height	mm	19.8
Outer diameter, min.	mm	18
Outer diameter, actuated	mm	18.5
Fitting size	-	None
Fitting option	-	None
Fitting style	-	None
Fitting type	-	None
Suction cup model	-	B15-2
Movement, vertical max.	mm	6.7
Curve radius, min.	mm	5

## Performance - Lifting forces

B15-2	Vertical (N)	Parallel (N)
20 -kPa	2.9	1.7
60 -kPa	5.9	3.2
90 -kPa	8.9	3.8

## Material

Name	HNBR 50° Shore A
Colour	Blue
Temperature, min.   °C	-30
Temperature max.   °C	140
Hardness   °Shore A	50

## Material resistance

Alcohol	Good
Concentrated acids	Fair
Ethanol	n/a
Hydrolysis	Good
Methanol	n/a
Oil	Excellent
Oxidation	Excellent
Petrol	Excellent
Wear resistance	Excellent
Weather and ozone	Excellent

## Dimensional drawings

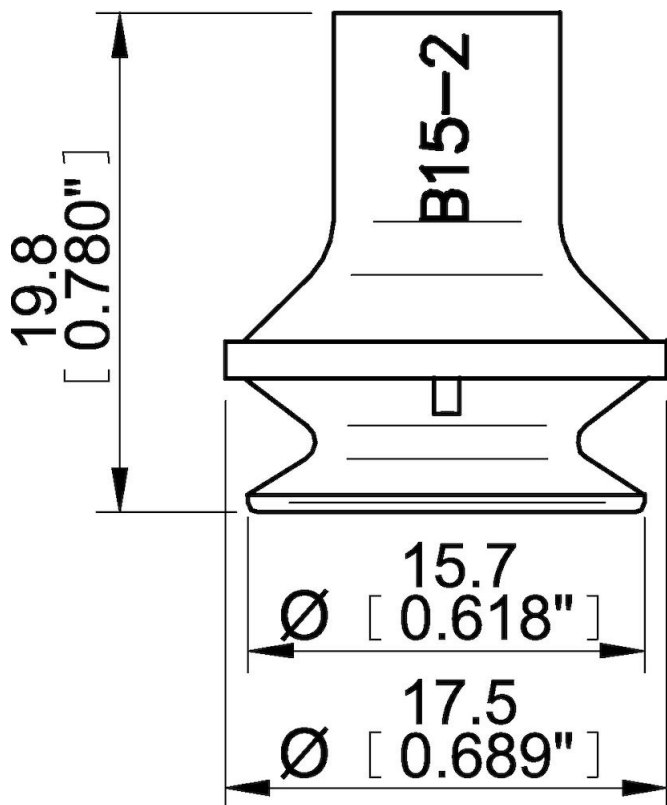

Values specified in this data sheet are tested at (unless otherwise stated):

- Room temperature (20°C [68°F] ± 3°C [5.5°F]).
- Standard atmosphere (101.3 [29.9 inHg] ± 1.0 kPa [0.3 inHg]).
- Relative humidity 20-70%.
- Compressed air quality, DIN ISO 8573-1 class 4.

## Accessories

3107030 | Fitting M5 male, 10-15