

piSAVE® onoff with large hysteresis

Article number: 0118200

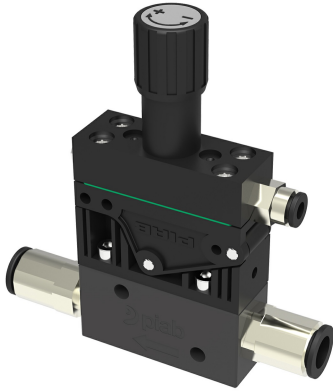

- Independent pneumatic air-saving device for vacuum pumps.
- Adjustable vacuum controlled 2/2 NO valve.
- Available with large hysteresis for object handling and small hysteresis for process applications.
- The Vacustat is recommended for vacuum pumps in non-leaking systems.
- The vacuum pump must be fitted with a non-return valve.

Technical data

Description	Unit	Value
Material	-	Al, CuZn, Nitrile (NBR), PA, SS
Temperature, max.	°C	60
Temperature, min.	°C	0
Weight, min.	g	103
Feed pressure, max. (@ vacuum connection)	MPa	0.6
Flow (@ P1=6 bar and Δp=0.5 bar)	NI/s	7.3
Valve function (2/2)	-	NO
Feed pressure, optimum, max.	MPa	0.7
Feed pressure, optimum, min.	MPa	0.17
Hysteresis	kPa	7.5 ±2.5
Life span	cycles	10000000
Signal range, max.	-kPa	99
Signal range, min.	-kPa	15
Height	mm	89.1
Length	mm	16.5
Width	mm	44

Dimensional drawings

