

Suction cup BL30-2 Silicone FCM, 1/8" NPSF female, with mesh filter

Article number: 9909641



- The silicone material complies with FDA 21 CFR 177.2600 & EU 1935/2004.
- Suitable for level adjustment.
- Lifting movement to separate small and thin objects.
- Less suitable when the lifting force is parallel to the surface of the object.

Technical data

Description	Unit	Value
Suction cup shape	-	Multibellows
Application	-	Bag handling, Food contact materials (FDA & EU), non-detectable
Suction cup design	-	Round
Characteristics	-	Bag handling, Food contact materials (FDA & EU), non-detectable
Material	-	Silicone (SIL)
Weight, min.	g	7
Suction cup model	-	BL-2
Volume	cm ³	10
Height	mm	40.5
Outer diameter, min.	mm	30
Fitting size	-	1/8"
Fitting option	-	Filter mesh
Fitting style	-	Female
Fitting type	-	NPSF-thread
Suction cup model	-	BL30-2
Movement, vertical max.	mm	18
Curve radius, min.	mm	8

Performance - Lifting forces

BL30-2	Vertical (N)	Parallel (N)
20 -kPa	7	
60 -kPa	18	

Material

Name	Silicone (SIL FDA) 50° Shore
Colour	Transparent
Temperature, min. °C	-40
Temperature max. °C	200
Hardness °Shore A	50

Material resistance

Alcohol	Good
Concentrated acids	Poor
Ethanol	n/a
Hydrolysis	Fair
Methanol	n/a
Oil	Poor
Oxidation	Excellent
Petrol	Poor
Wear resistance	Good
Weather and ozone	Excellent

Dimensional drawings

1/8" NPSF

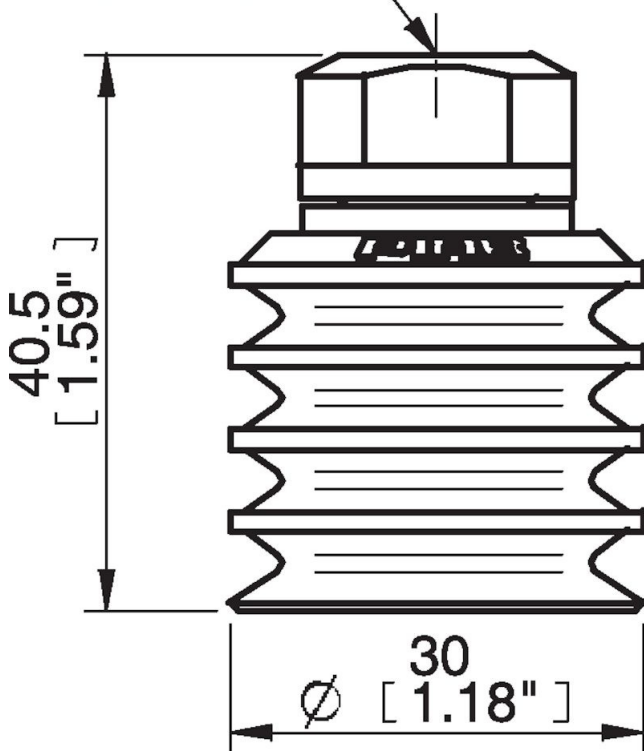

Values specified in this data sheet are tested at (unless otherwise stated):

- Room temperature (20°C [68°F] ± 3°C [5.5°F]).
- Standard atmosphere (101.3 [29.9 inHg] ± 1.0 kPa [0.3 inHg]).
- Relative humidity 20-70%.
- Compressed air quality, DIN ISO 8573-1 class 4.

Accessories

- 3250091 | Fitting G1/4" male, 30–40, with mesh filter
- 3250093 | Fitting 1/4" NPT male, with mesh filter

Spare parts

- 0101153 | Fitting 1/8" NPSF female, 30–40, with mesh filter
- 0200411 | Suction cup BL30-2 Silicone FCM