

# Suction cup F-OB 20x40 Silicone, G1/4" male SS, FCM

Article number: 0207045



- The silicone material complies with FDA 21 CFR 177.2600 and EU 1935/2004.
- Transparent color without pigment
- Long lasting high-end silicone material
- Excellent grip on oblong parts such as flow-packs and stick-packs
- Available with threaded and integrated stainless steel fittings.
- Easy to clean with hygienic design. No dust/dirt pockets.

## Technical data

Description	Unit	Value
Suction cup shape	-	Bellows
Application	-	Food contact materials (FDA & EU), non-detectable
Suction cup design	-	Oval
Characteristics	-	Food contact materials (FDA & EU), non-detectable
Material	-	Silicone (SIL)
Load, torque, max.	Nm	13
Weight, min.	g	42.5
Suction cup model	-	F-OB
Volume	cm <sup>3</sup>	5
Height	mm	41.2
Length	mm	40.8
Fitting size	-	1/4"
Fitting option	-	None
Fitting style	-	Male
Fitting type	-	G-thread
Width	mm	20.8
Material	-	ASTM 316L
Suction cup model	-	F-OB 20x40
Movement, vertical max.	mm	7.6
Curve radius, min.	mm	9

## Performance - Lifting forces

F-OB 20x40	Vertical (N)	Parallel (N)
10 -kPa	3.3	2.9
20 -kPa	6.9	6
40 -kPa	12	12.6

## Material

Name	Silicone (SIL non-detectable FCM)
Colour	Transparent
Temperature, min.   °C	-40
Temperature max.   °C	200
Hardness   °Shore A	40

## Material resistance

Alcohol	Good
Concentrated acids	Poor
Ethanol	n/a
Hydrolysis	Fair
Methanol	n/a
Oil	Poor
Oxidation	Excellent
Petrol	Poor
Wear resistance	Good
Weather and ozone	Excellent

## Dimensional drawings

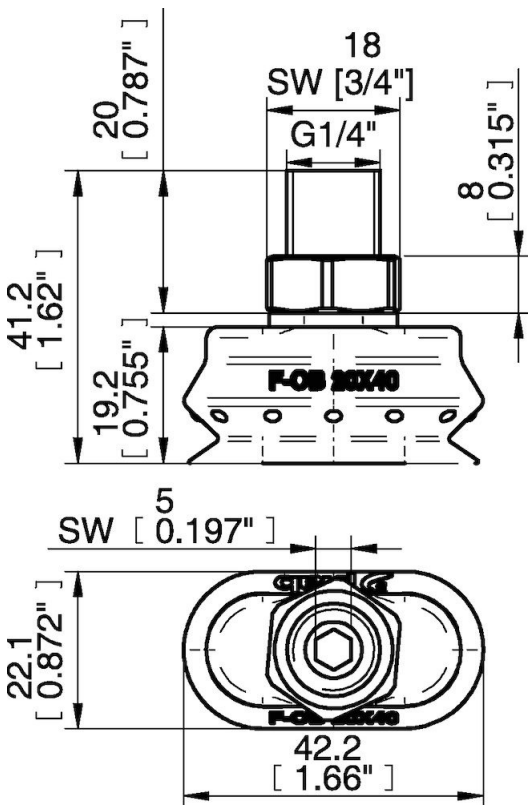

Values specified in this data sheet are tested at (unless otherwise stated):

- Room temperature (20°C [68°F] ± 3°C [5.5°F]).
- Standard atmosphere (101.3 [29.9 inHg] ± 1.0 kPa [0.3 inHg]).
- Relative humidity 20-70%.
- Compressed air quality, DIN ISO 8573-1 class 4.