

Suction cup BL30-5 Silicone FCM, 1/4" NPT male

Article number: 9909652



- The silicone material complies with FDA 21 CFR 177.2600 & EU 1935/2004 and meets EU's regulation EU 1935/2004.
- High initial flow, with re-enforced bellows and long, thin lip
- Suitable for handling difficult-to-handle bags, e.g., bags filled with liquid, frozen food, and for heavy bags
- Suitable working temperature is -40–200 °C
- Suitable for level compensation

Technical data

Description	Unit	Value
Suction cup shape	-	Multibellows
Application	-	Bag handling, Food contact materials (FDA & EU), non-detectable
Suction cup design	-	Round
Characteristics	-	Bag handling, Food contact materials (FDA & EU), non-detectable
Material	-	Silicone (SIL)
Weight, min.	g	14.5
Suction cup model	-	BL-5
Volume	cm ³	8.55
Height	mm	54
Outer diameter, min.	mm	30.5
Fitting size	-	1/4"
Fitting option	-	None
Fitting style	-	Male
Fitting type	-	NPT-thread
Suction cup model	-	BL30-5
Movement, vertical max.	mm	11
Curve radius, min.	mm	17

Performance - Lifting forces

BL30-5	Vertical (N)	Parallel (N)
20 -kPa	8	3
60 -kPa	9	5.5

Material

Name	Silicone FDA 40° Shore A
Colour	Transparent
Temperature, min. °C	-40
Temperature max. °C	200
Hardness °Shore A	40

Material resistance

Alcohol	Good
Concentrated acids	Poor
Ethanol	n/a
Hydrolysis	Fair
Methanol	n/a
Oil	Poor
Oxidation	Excellent
Petrol	Poor
Wear resistance	Good
Weather and ozone	Excellent

Dimensional drawings

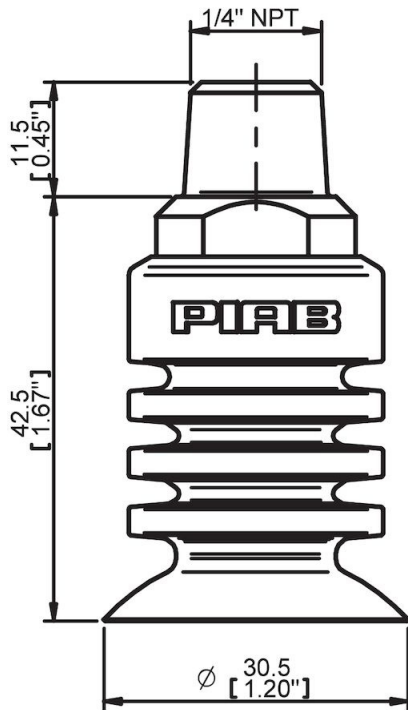

Values specified in this data sheet are tested at (unless otherwise stated):

- Room temperature (20°C [68°F] ± 3°C [5.5°F]).
- Standard atmosphere (101.3 [29.9 inHg] ± 1.0 kPa [0.3 inHg]).
- Relative humidity 20-70%.
- Compressed air quality, DIN ISO 8573-1 class 4.

Accessories

0118793 | Fitting G1/4" male, bag

Spare parts

0118794 | Fitting 1/4" NPT male, bag

0200239 | Suction cup BL30-5 Silicone FCM