

Suction cup BFFT70P Polyurethane 60/60/30, G3/8" female plastic

Article number: 0206528



- Special designed friction cups for thin (0.6-0.8 mm) oily metal sheets, such as outer body car parts in a press-to press forming process.
- Long lasting material, normal wear on friction cup will not affect the long term grip performance.
- Refined internal friction pattern provides additional grip performance, the suction cups can withstand high shear forces, typically 3–5 times more than corresponding conventional suction cups.
- Best choice if > 0.1g/m² press oil is used on the sheet but also a great choice for dry metal sheets.
- The "BFFT" design is suitable for thin flat or uneven/curved surfaces and if level compensation is needed, for example in de-stacking applications.
- The flat inner support, made of dual hardness, gives stability and good grip during movement in any orientation.
- DURAFLEX® suction cups manufactured in a specially developed material that features the elasticity of rubber and wear resistance of polyurethane. The material does not leave any marks on the objects handled and has a fantastic elastic memory, even after hundreds of thousands of cycles.

Technical data

| Description | Unit | Value |
|--------------------------|-----------------|--------------------------|
| Suction cup shape | - | Bellows |
| Application | - | Oily sheet metal |
| Suction cup design | - | Round |
| Characteristics | - | Oily sheet metal |
| Material | - | Polyurethane (PU) |
| Weight, min. | g | 34.2 |
| Suction cup model | - | BFFT |
| Volume | cm ³ | 36.4 |
| Height | mm | 41.7 |
| Outer diameter, min. | mm | 73 |
| Outer diameter, actuated | mm | 75 |
| Fitting size | - | 3/8" |
| Fitting option | - | Filter mesh |
| Fitting style | - | Female |
| Fitting type | - | G-thread |
| Suction cup model | - | BFFT70P Oily metal sheet |
| Movement, vertical max. | mm | 14 |
| Curve radius, min. | mm | 95 |
| Suction cup model | - | BFFT70P Dry metal sheet |
| Movement, vertical max. | mm | 14 |
| Curve radius, min. | mm | 95 |

Performance - Lifting forces

| BFFT70P Oily metal sheet | Vertical (N) | Parallel (N) |
|--------------------------|--------------|--------------|
| 60 -kPa | 131 | 46 |

| | | |
|--------------------------|--------------|--------------|
| BFFT70P Oily metal sheet | Vertical (N) | Parallel (N) |
| 90 -kPa | 174 | 68 |
| BFFT70P Dry metal sheet | | |
| 60 -kPa | 164 | 69 |
| 90 -kPa | 182 | 88 |

| Material | | | |
|------------------------|---------------------|---------------------|---------------------|
| Name | Polyurethane (PU30) | Polyurethane (PU60) | Polyurethane (PU60) |
| Colour | Yellow | Green transparent | Orange |
| Temperature, min. °C | 10 | 10 | 10 |
| Temperature max. °C | 50 | 50 | 50 |
| Hardness °Shore A | 30 | 60 | 60 |

| Material resistance | | | |
|---------------------|-----------|-----------|-----------|
| Alcohol | n/a | n/a | n/a |
| Concentrated acids | Fair | Fair | Fair |
| Ethanol | Fair | Fair | Fair |
| Hydrolysis | Fair | Fair | Fair |
| Methanol | Poor | Poor | Poor |
| Oil | Excellent | Excellent | Excellent |
| Oxidation | Poor | Poor | Poor |
| Petrol | Fair | Fair | Fair |
| Wear resistance | Excellent | Excellent | Excellent |
| Weather and ozone | Excellent | Excellent | Excellent |

Dimensional drawings

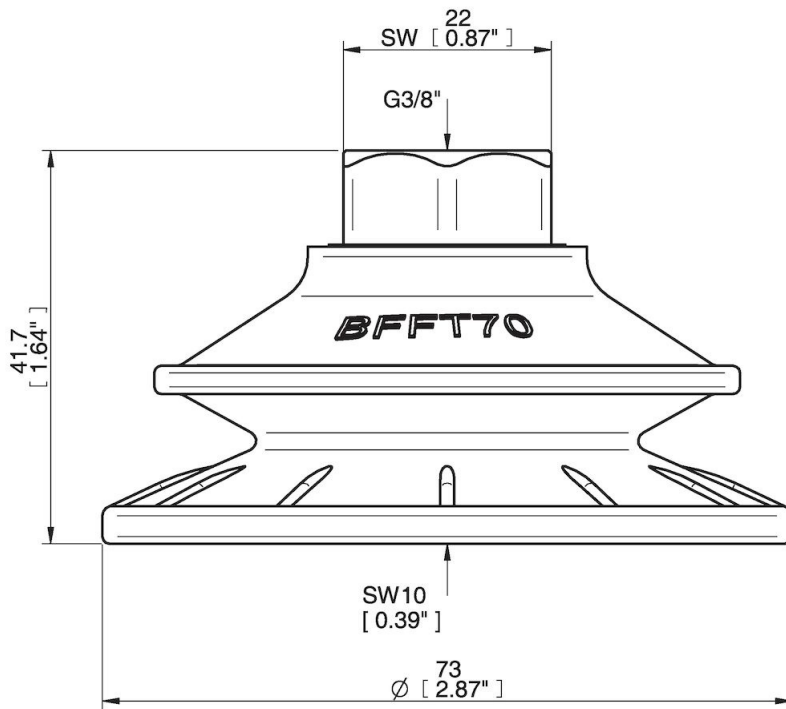

Values specified in this data sheet are tested at (unless otherwise stated):

- Room temperature (20°C [68°F] ± 3°C [5.5°F]).
- Standard atmosphere (101.3 [29.9 inHg] ± 1.0 kPa [0.3 inHg]).
- Relative humidity 20-70%.
- Compressed air quality, DIN ISO 8573-1 class 4.