

Suction cup F15 Silicone FCM, M5 male

Article number: 9909623



- The silicone material complies with FDA 21 CFR 177.2600 & EU 1935/2004.
- Suitable for flat objects.
- Good stability and little inherent movement.
- Recommended when the lifting force is parallel to the surface of the object.
- Cleats prevent thin, sensitive objects from being deformed and gives extra friction when the lifting force is parallel.

Technical data

Description	Unit	Value
Suction cup shape	-	Flat
Application	-	Food contact materials (FDA & EU), non-detectable
Suction cup design	-	Round
Characteristics	-	Food contact materials (FDA & EU), non-detectable
Material	-	Silicone (SIL)
Weight, min.	g	0.9
Suction cup model	-	F
Volume	cm ³	0.37
Height	mm	19.5
Outer diameter, min.	mm	15.7
Outer diameter, actuated	mm	16.1
Fitting size	-	None
Fitting option	-	None
Fitting style	-	Male
Fitting type	-	M-thread
Suction cup model	-	F15
Movement, vertical max.	mm	1
Curve radius, min.	mm	13

Performance - Lifting forces

F15	Vertical (N)	Parallel (N)
20 -kPa	3.5	3.5
60 -kPa	8.5	6.5
90 -kPa	11	7.5

Material

Name	Silicone (SIL FDA) 50° Shore
Colour	Transparent
Temperature, min. °C	-40
Temperature max. °C	200
Hardness °Shore A	50

Material resistance

Alcohol	Good
Concentrated acids	Poor
Ethanol	n/a
Hydrolysis	Fair
Methanol	n/a
Oil	Poor
Oxidation	Excellent
Petrol	Poor
Wear resistance	Good
Weather and ozone	Excellent

Dimensional drawings

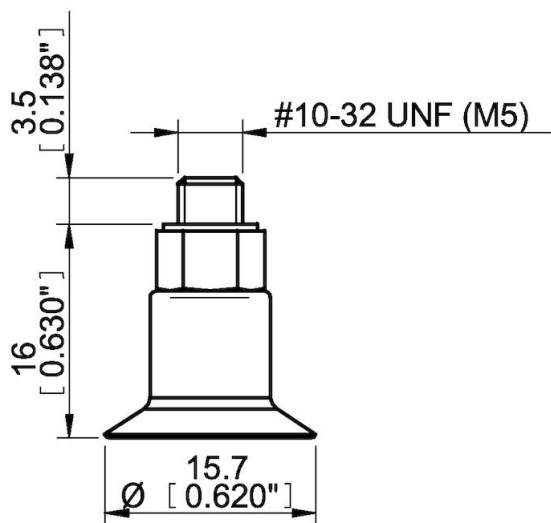

Values specified in this data sheet are tested at (unless otherwise stated):

- Room temperature (20°C [68°F] ± 3°C [5.5°F]).
- Standard atmosphere (101.3 [29.9 inHg] ± 1.0 kPa [0.3 inHg]).
- Relative humidity 20-70%.
- Compressed air quality, DIN ISO 8573-1 class 4.

Spare parts

0200263 | Suction cup F15 Silicone FCM
3107030 | Fitting M5 male, 10-15