

Value Line® T-design vacuum generator 6mm

Article number: 0202187



- Ejector with improved vacuum performance compared to corresponding size conventional single-stage ejector.
- Ejector stage without flap valve gives high reliability in dirty and dusty environments.
- Light weight body.
- Integrated push-in fittings or thread connection for quick and low cost installation.
- Available in “Inline”, “T-design” or aluminum block version.
- The T-design is suitable if exhaust air needs to be piped away.
- The VL206 1/8” block version is an easy-to-install alternative, targeting operators of basic automated vacuum systems.

Technical data

Description	Unit	Value
Material	-	CuZn, Nitrile (NBR), PA, SS
Temperature, max.	°C	80
Temperature, min.	°C	-10
Weight, min.	g	12
Feed pressure, max.	MPa	0.7
Noise level, max.	dBA	78
Noise level, min.	dBA	72
Feed pressure, optimum, min.	MPa	0.5
Air consumption (at optimum feed pressure)	NI/s	0.32

Performance

Feed pressure MPa	Air consumption NI/s	Vacuum flow (NI/s) at different vacuum levels (-kPa)														Max vacuum kPa
		0	10	20	30	40	50	60	70	75	80	90	95	99		
0.5	0.32	0.29	0.26	0.23	0.2	0.15	0.1	0.05	0	0	0	0	0	0	0	≥70

Feed pressure MPa	Air consumption NI/s	Evacuation time (s/l) to reach different vacuum levels (-kPa)														Max vacuum kPa
		10	20	30	40	50	60	70	80	90	95	99	99.5	100.3		
0.5	0.32	0.36	0.77	1.14	1.81	2.61	3.94	0	0	0	0	0	0	0	0	≥70

Dimensional drawings

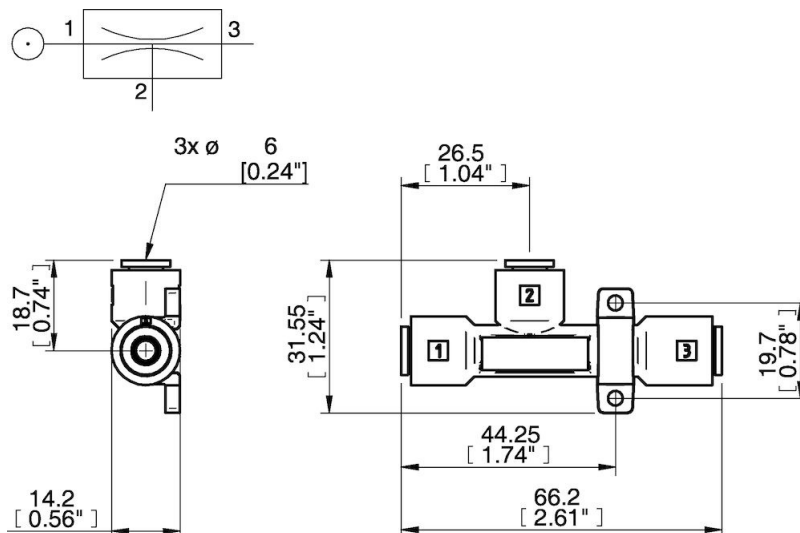

Values specified in this data sheet are tested at (unless otherwise stated):

- Room temperature (20°C [68°F] ± 3°C [5.5°F]).
- Standard atmosphere (101.3 [29.9 inHg] ± 1.0 kPa [0.3 inHg]).
- Compressed air quality, DIN ISO 8573-1 class 4.