

Suction cup D20-2 Silicone FCM, G1/8" male, with mesh filter

Article number: 9909712



- The silicone material complies with FDA 21 CFR 177.2600 & EU 1935/2004.
- Suitable for objects with curved or irregular surfaces.
- Grips around corners and edges.

Technical data

Description	Unit	Value
Suction cup shape	-	Deep
Application	-	Food contact materials (FDA & EU), non-detectable
Suction cup design	-	Round
Characteristics	-	Food contact materials (FDA & EU), non-detectable
Material	-	Silicone (SIL)
Weight, min.	g	2.2
Suction cup model	-	D
Volume	cm ³	2.5
Height	mm	25.2
Outer diameter, min.	mm	22
Fitting size	-	1/8"
Fitting option	-	Filter mesh
Fitting style	-	Male
Fitting type	-	G-thread
Suction cup model	-	D20-2
Movement, vertical max.	mm	2.8
Curve radius, min.	mm	8

Performance - Lifting forces

D20-2	Vertical (N)	Parallel (N)
20 -kPa	5.9	5
60 -kPa	15	8
90 -kPa	18	8.5

Material

Name	Silicone (SIL FDA) 50° Shore
Colour	Transparent
Temperature, min. °C	-40
Temperature max. °C	200
Hardness °Shore A	50

Material resistance

Alcohol	Good
Concentrated acids	Poor
Ethanol	n/a
Hydrolysis	Fair
Methanol	n/a
Oil	Poor
Oxidation	Excellent
Petrol	Poor
Wear resistance	Good
Weather and ozone	Excellent

Dimensional drawings

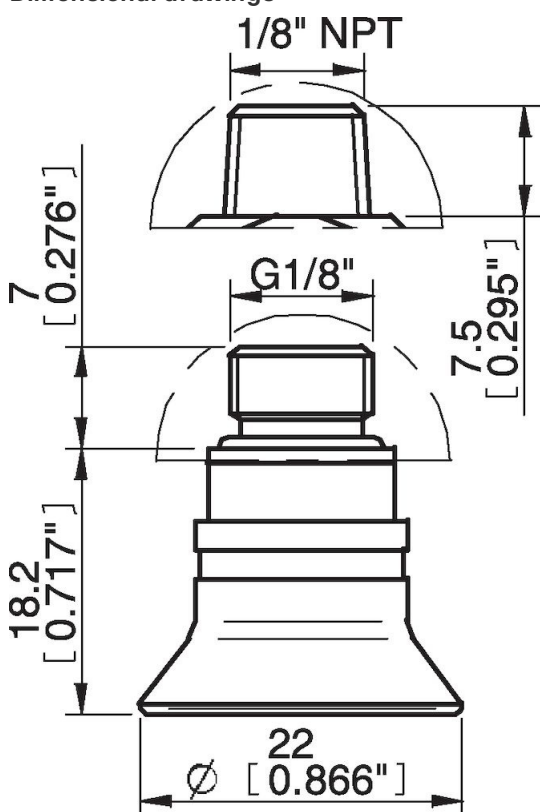

Values specified in this data sheet are tested at (unless otherwise stated):

- Room temperature (20°C [68°F] ± 3°C [5.5°F]).
- Standard atmosphere (101.3 [29.9 inHg] ± 1.0 kPa [0.3 inHg]).
- Relative humidity 20-70%.
- Compressed air quality, DIN ISO 8573-1 class 4.