

COAX® cartridge MINI Si08-3

Article number: 0113214



- Three-stage COAX® cartridge - MINI - with extra high initial vacuum flow.
- Large vacuum flow in relation to energy consumption.
- Good for handling porous materials or if surface leakage is present. Recommended for high speed applications.

Technical data

Description	Unit	Value
Material	-	Al, Nitrile (NBR), PA, SS
Temperature, max.	°C	80
Temperature, min.	°C	-10
Weight, max.	g	12.7
Weight, min.	g	4.9
Feed pressure, max.	MPa	0.7

Performance

Feed pressure MPa	Air consumption NI/s	Vacuum flow (NI/s) at different vacuum levels (-kPa)														Max vacuum kPa
		0	10	20	30	40	50	60	70	75	80	90	95	99		
0.4	0.31	1.1	0.57	0.36	0.26	0.18	0.09	0	0	0	0	0	0	0	0	≥60
0.5	0.38	1.23	0.65	0.46	0.29	0.23	0.15	0.08	0.01	0	0	0	0	0	0	≥70
0.6	0.44	1.34	0.73	0.55	0.35	0.23	0.17	0.13	0.08	0	0	0	0	0	0	≥75

Feed pressure MPa	Air consumption NI/s	Evacuation time (s/l) to reach different vacuum levels (-kPa)														Max vacuum kPa
		10	20	30	40	50	60	70	80	90	95	99	99.5	100.3		
0.4	0.31	0.12	0.33	0.66	1.1	1.9	0	0	0	0	0	0	0	0	0	≥60
0.5	0.38	0.11	0.29	0.55	0.9	1.5	2.3	4.6	0	0	0	0	0	0	0	≥70
0.6	0.44	0.1	0.25	0.48	0.8	1.3	2	2.9	0	0	0	0	0	0	0	≥75

Feed pressure MPa	Air consumption NI/s	Blow flow (NI/s) at different pressure levels (-kPa)														Max pressure kPa	
		0	10	20	30	40	50	60	70	80	90	100	110	120	130		140
0.6	0.44	1.78	1.16	1.03	0.86	0.8	0.75	0.66	0.53	0	0	0	0	0	0	0	≥75

Dimensional drawings

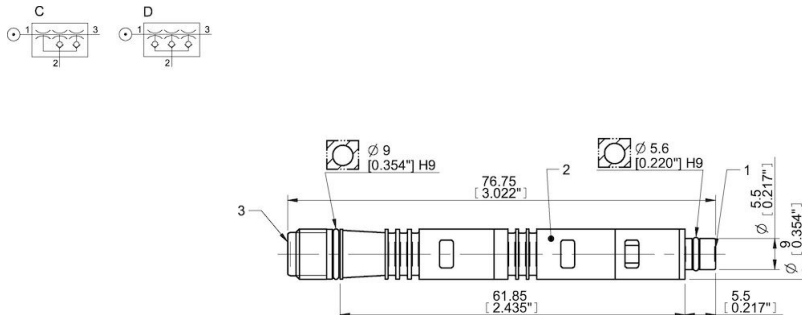

Values specified in this data sheet are tested at (unless otherwise stated):

- Room temperature (20°C [68°F] ± 3°C [5.5°F]).
- Standard atmosphere (101.3 [29.9 inHg] ± 1.0 kPa [0.3 inHg]).
- Compressed air quality, DIN ISO 8573-1 class 4.

Accessories

0106344 | Exhaust adapter

0111977 | Silencer COAX® MINI