

# Suction cup U6 HNBR, M5 male

Article number: 9914275



- Suitable for objects with flat or slightly curved surfaces.
- Also used for concave objects.

## Technical data

Description	Unit	Value
Suction cup shape	-	Universal
Application	-	Mark Free
Suction cup design	-	Round
Characteristics	-	Mark free
Material	-	HNBR
Weight, min.	g	0.14
Suction cup model	-	U
Volume	cm <sup>3</sup>	0.05
Height	mm	14.5
Outer diameter, min.	mm	7
Fitting size	-	None
Fitting option	-	None
Fitting style	-	Male
Fitting type	-	M-thread
Suction cup model	-	U6
Movement, vertical max.	mm	0.3
Curve radius, min.	mm	5

## Performance - Lifting forces

U6	Vertical (N)	Parallel (N)
20 -kPa	0.5	0.5
60 -kPa	1.7	1.5
90 -kPa	2.5	2

## Material

Name	HNBR 50° Shore A
Colour	Blue
Temperature, min.   °C	-30
Temperature max.   °C	140
Hardness   °Shore A	50

## Material resistance

Alcohol	Good
Concentrated acids	Fair
Ethanol	n/a
Hydrolysis	Good
Methanol	n/a
Oil	Excellent
Oxidation	Excellent
Petrol	Excellent
Wear resistance	Excellent

Water and ozone

Name HNBR 50° Shore A

Dimensional drawings

	Blue
	-30
	140
	50
	Good
	Fair
	n/a
	Good
	n/a
	Excellent
	Excellent
	Excellent
	Excellent
	Excellent

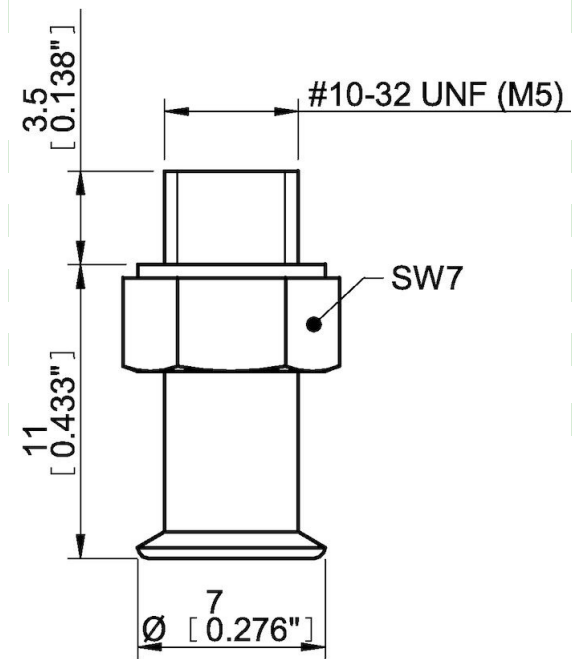

Values specified in this data sheet are tested at (unless otherwise stated):

- Room temperature (20°C [68°F] ± 3°C [5.5°F]).
- Standard atmosphere (101.3 [29.9 inHg] ± 1.0 kPa [0.3 inHg]).
- Relative humidity 20-70%.
- Compressed air quality, DIN ISO 8573-1 class 4.

Accessories

3150115 | Suction cup U6 Chloroprene

3150115S | Suction cup U6 Silicone

Spare parts

0200888 | Suction cup U6 HNBR

3107031 | Fitting M5 male, 5-8