

Suction cup U15-3 Silicone, M5 male

Article number: 0117947



- Wide temperature range (-40°C to +200°C)
- Reinforced lip

Technical data

Description	Unit	Value
Suction cup shape	-	Universal
Application	-	Bag opening/thin paper - slip sheets/film
Suction cup design	-	Round
Characteristics	-	Bag opening/thin paper - slip sheets/film
Material	-	Silicone (SIL)
Weight, min.	g	0.7
Suction cup model	-	U
Volume	cm ³	0.5
Height	mm	20
Outer diameter, min.	mm	16.5
Fitting size	-	M5
Fitting option	-	None
Fitting style	-	Male
Fitting type	-	M-thread
Suction cup model	-	U15
Movement, vertical max.	mm	1.5
Curve radius, min.	mm	8

Performance - Lifting forces

U15	Vertical (N)	Parallel (N)
20 -kPa	3.5	4
60 -kPa	8.4	7.2
90 -kPa	11	8.1

Material

Name	Silicone, SIL 50° Shore A
Colour	Red
Temperature, min. °C	-40
Temperature max. °C	200
Hardness °Shore A	50

Material resistance

Alcohol	Good
Concentrated acids	Poor
Ethanol	n/a
Hydrolysis	Fair
Methanol	n/a
Oil	Poor
Oxidation	Excellent
Petrol	Poor
Wear resistance	Good

Material and ozone	Excellent
Name	Silicone, SIL 50° Shore A
Dimensional drawings	Red
	-40
	200
	50
	Good
	Poor
	n/a
	Fair
	n/a
	Poor
	Excellent
	Poor
	Good
	Excellent

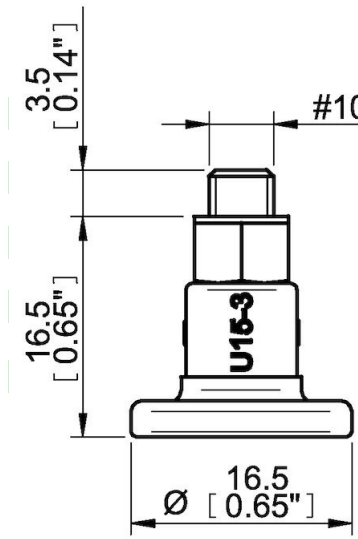

Values specified in this data sheet are tested at (unless otherwise stated):

- Room temperature (20°C [68°F] ± 3°C [5.5°F]).
- Standard atmosphere (101.3 [29.9 inHg] ± 1.0 kPa [0.3 inHg]).
- Relative humidity 20-70%.
- Compressed air quality, DIN ISO 8573-1 class 4.

Spare parts

- 0114981 | Suction cup U15-3 Silicone
- 3107030 | Fitting M5 male, 10-15