

VGS4005, SX42 Ø 1/4"

Article number: 0231210



- Light weight vacuum gripper ejector with plastic housing
- VGS4005 with SX12 or SX42 cartridge without flap valves, a COAX® chosen for very harsh environments, combining high dust and high humidity levels
- Optimal in applications when less vacuum depth is needed, such as bag/pouch handling etc
- Reduced noise level with Integrated silencer
- VGS4005 is compatible with any suction cup with G3/8" male fitting from Piab's assortment.

Technical data

Description	Unit	Value
Material	-	Al, CuZn, Nitrile (NBR), PA, POM, PPM, Polyurethane (PU), SS
Load, vertical, max.	N	70
Temperature, max.	°C	80
Temperature, min.	°C	-10
Weight, min.	g	71
Feed pressure, max.	MPa	0.7
Noise level, max.	dBA	85
Noise level, min.	dBA	74

Performance

Feed pressure MPa	Air consumption Nl/s	Vacuum flow (Nl/s) at different vacuum levels (-kPa)														Max vacuum kPa	
		0	10	20	30	40	50	60	70	75	80	90	95	99			
0.43	2.21	3.46	3.02	2.41	1.7	1.02	0.24	0	0	0	0	0	0	0	0	0	≥53
0.5	2.5	3.46	3.02	2.43	1.73	1.13	0.55	0	0	0	0	0	0	0	0	0	≥59
0.6	2.92	3.4	2.99	2.5	1.97	1.4	0.82	0.27	0	0	0	0	0	0	0	0	≥64

Feed pressure MPa	Air consumption Nl/s	Evacuation time (s/l) to reach different vacuum levels (-kPa)											Max vacuum kPa				
		10	20	30	40	50	60	70	80	90	95	99		99.5	100.3		
0.43	2.21	0.031	0.068	0.116	0.19	0.349	0	0	0	0	0	0	0	0	0	0	≥53
0.5	2.5	0.031	0.068	0.116	0.186	0.305	0	0	0	0	0	0	0	0	0	0	≥59
0.6	2.92	0.031	0.068	0.112	0.172	0.262	0.445	0	0	0	0	0	0	0	0	0	≥64

Dimensional drawings

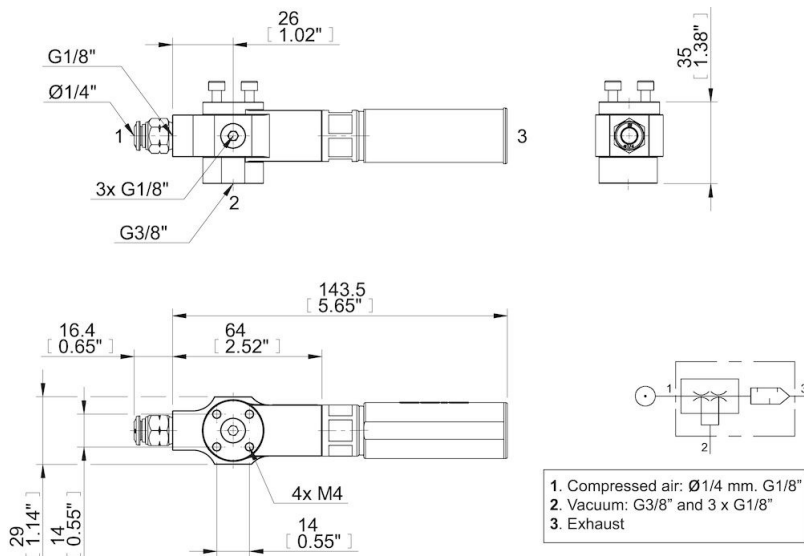

Values specified in this data sheet are tested at (unless otherwise stated):

- Room temperature (20°C [68°F] ± 3°C [5.5°F]).

- Standard atmosphere (101.3 [29.9 inHg] \pm 1.0 kPa [0.3 inHg]).
- Compressed air quality, DIN ISO 8573-1 class 4.