

COAX® cartridge MINI Pi12-3, holding cap, extra non-return valve

Article number: 0106957



- Three-stage COAX® cartridge - MINI - with high initial vacuum flow.
- Vacuum level to 90 -kPa at low feed pressure.
- High system reliability in case of fluctuating or low feed pressure.
- Suitable for handling sealed objects with high pick-up speed.

Technical data

Description	Unit	Value
Material	-	Al, Nitrile (NBR), PA, SS
Temperature, max.	°C	80
Temperature, min.	°C	-10
Weight, max.	g	12.5
Weight, min.	g	4.7
Feed pressure, max.	MPa	0.7

Performance

Feed pressure MPa	Air consumption NI/s	Vacuum flow (NI/s) at different vacuum levels (-kPa)													Max vacuum kPa		
		0	10	20	30	40	50	60	70	75	80	90	95	99			
0.17	0.29	0.9	0.4	0.22	0.15	0.07	0	0	0	0	0	0	0	0	0	0	≥49
0.22	0.34	1.1	0.48	0.29	0.2	0.14	0.08	0.02	0	0	0	0	0	0	0	0	≥64
0.32	0.44	1.4	0.6	0.44	0.27	0.19	0.14	0.1	0.06	0	0.03	0	0	0	0	0	≥90
0.4	0.53	1.4	0.7	0.52	0.39	0.24	0.12	0.1	0.06	0	0.02	0	0	0	0	0	≥84
0.6	0.79	1.6	1	0.5	0.41	0.36	0.28	0.17	0.05	0	0.01	0	0	0	0	0	≥83

Feed pressure MPa	Air consumption NI/s	Evacuation time (s/l) to reach different vacuum levels (-kPa)													Max vacuum kPa		
		10	20	30	40	50	60	70	80	90	95	99	99.5	100.3			
0.17	0.29	0.15	0.46	1	2	0	0	0	0	0	0	0	0	0	0	0	≥49
0.22	0.34	0.1	0.32	0.75	1.4	2.2	2.9	0	0	0	0	0	0	0	0	0	≥64
0.32	0.44	0.08	0.23	0.49	1	1.7	2.6	3.9	6.3	0	0	0	0	0	0	0	≥90
0.4	0.53	0.09	0.24	0.45	0.76	1.4	2.4	3.7	7	0	0	0	0	0	0	0	≥84
0.6	0.79	0.06	0.17	0.37	0.65	1	1.4	2.4	9	0	0	0	0	0	0	0	≥83

Feed pressure MPa	Air consumption NI/s	Blow flow (NI/s) at different pressure levels (-kPa)													Max pressure kPa		
		0	10	20	30	40	50	60	70	80	90	100	110	120		130	140
0.6	0.79	1.87	1.635	1.4	1.365	1.33	1.225	1.12	1.03	1.03	1.03	1.03	1	0.95	0.86	0.79	≥83

Dimensional drawings

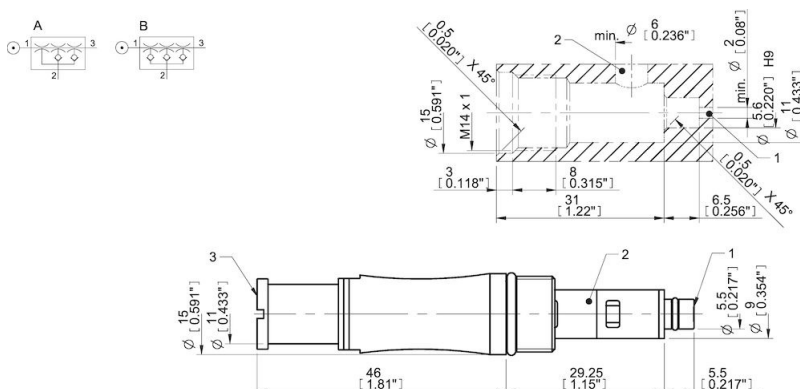

Values specified in this data sheet are tested at (unless otherwise stated):

- Room temperature (20°C [68°F] ± 3°C [5.5°F]).
- Standard atmosphere (101.3 [29.9 inHg] ± 1.0 kPa [0.3 inHg]).
- Compressed air quality, DIN ISO 8573-1 class 4.

Accessories

0106344 | Exhaust adapter

0111977 | Silencer COAX® MINI