

Level compensator G1/2"

Article number: 3350071



- Adjust differences in levels, for example on lifting devices with several suction cups on a frame.
- A level compensator is often advantageous since it places less demand on exact vertical positioning, for example on a handling robot.
- The level compensator provides a certain degree of shock absorption.
- Level Compensator G1/2" with stiffer spring is identical to standard level compensator G1/2" except for thicker spring material. Suits e.g. robot vision systems in applications such as auto-racking.

Technical data

Description	Unit	Value
Material	-	Steel
Load, vertical, max.	N	490
Temperature, max.	°C	90
Temperature, min.	°C	-20
Weight, min.	g	160
Action range/Stroke	mm	15
Spring constant	N/mm	0.93
Spring force, max.	N	37
Spring force, min.	N	24

Dimensional drawings

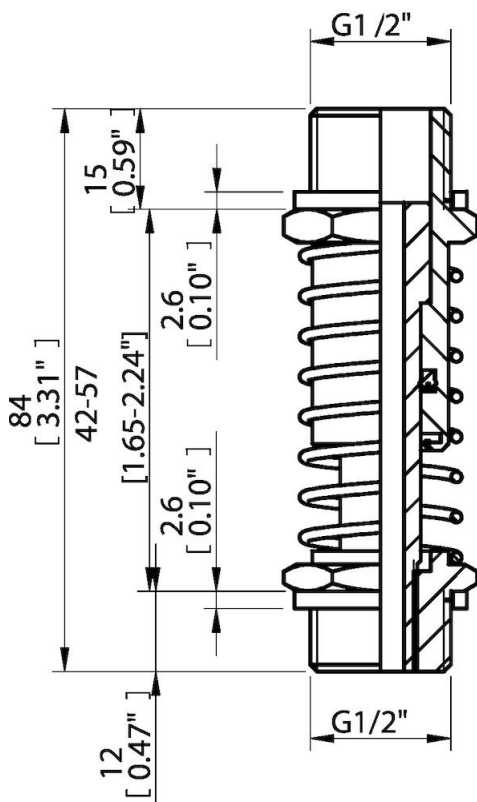

Accessories

3107757 | Connector ext-int G1/2"