

TEGUFLEX® P HP



EXPANSION JOINT MOULDED

APPLICATIONS

Hot water, steam, hot air up to 130°

ADVANTAGES

Compensate thermal elongation
Isolate vibrations and absorb pressure surges
Correct misalignments

FLANGES

Turnable flanges in zinc plated carbon steel S235JR
Other material: stainless steel 316, hot-dip galvanized, EPOXY painting, etc.
EN 1092 PN6/10/16- ASME B16.5 150lbs. Other types on request.

COMPLEMENTARY INFORMATION

BL = 130 mm
Inner liner PTFE, vacuum ring (316Ti), flameguards, PTFE safety shields on request.

Type Approvals: DNV-GL and ABS
PED (2014/68/EU)

TECHNICAL DESCRIPTION

Inner tube: EPDM special, black, fluted.

Reinforcement: Aramid

Cover: EPDM special, black, smooth, weather and ozone resistant.

Temperature range: -35°C => 130°C.

Max 130°C at max WP 10 bar (≤ DN150) / 6 bar (>DN150) // Max 100°C at max WP 16 bar (≤ DN150) / 10 bar (>DN150)

STANDARD/APPROVAL

ABS

ABS

DNV

DNV



LABELING



TRELLEBORG IZARRA IZARRA-ALAVA-SPAIN Batch number - Working pressure - Testing pressure - T MAX/MIN - DN - Month/Year

TEGUFLEX® P HP

DIMENSIONS & MOVEMENTS

DN	BL	Eff. cross-sectional area Q	(E)	(F)	Permissible movements				Max. vacuum		Weight		Spring rates		
					Compression	Elongation	Lateral	Angular	Without support ring	With support ring	With flanges	With tie-rod flanges	Compression stiffness	Elongation stiffness	Lateral stiffness
mm	mm	cm ²	mm	mm	mm	mm	mm	°	bar	bar	kg	kg	kg/cm	kg/cm	kg/cm
25/32	130	35	77	72	30	20	20	35°	0.8	1.0	2.8	4.5	50	75	50
40	130	50	85	80	30	20	20	35°	0.8	1.0	3.3	4.8	50	75	50
50	130	74	95	90	30	20	20	35°	0.7	1.0	3.7	5.0	50	75	50
65	130	87	110	105	30	20	20	30°	0.6	1.0	4.8	6.4	50	75	50
80	130	120	125	120	30	20	20	30°	0.5	1.0	5.3	7.5	50	75	50
100	130	143	145	140	30	20	20	25°	0.5	1.0	6.2	9.0	65	85	65
125	130	210	170	165	30	20	20	25°	0.4	1.0	8.2	11.2	65	85	65
150	130	283	195	190	30	20	20	15°	0.3	1.0	11.2	13.4	75	100	75
200	130	525	245	240	30	20	20	15°	0.3	1.0	16.8	19.4	75	100	75
250	130	636	295	290	30	20	20	10°	0.2	1.0	21.6	25.4	100	150	100
300	130	897	345	340	30	20	20	10°	0.2	1.0	30.1	33.1	100	150	100

Note: Maximum values do not apply simultaneously. Stiffness values tolerance: +/- 20%.

Unless typographical error, information and figures of our technical datasheet are based on our experience and laboratory tests according to international standards. This data is intended to be used as a guideline only. Material performance depends on the conditions of use and the final application.

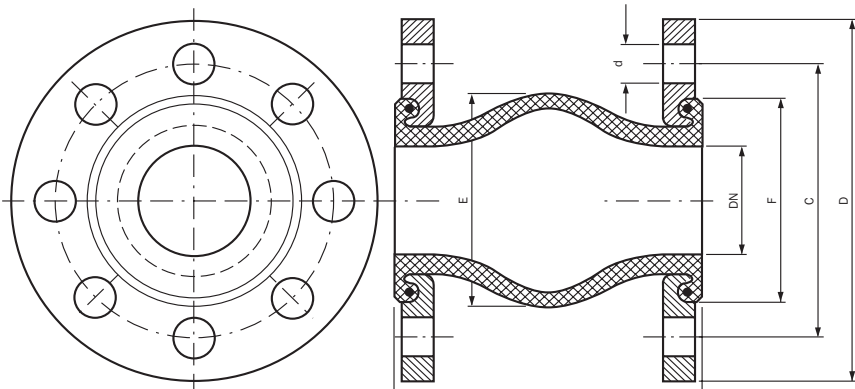

U Type

Standard unit for axial, lateral and angular movements.

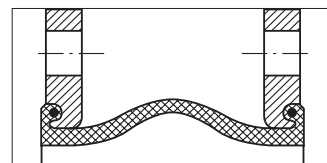

L Type

Unit with tie bars for lateral movements.

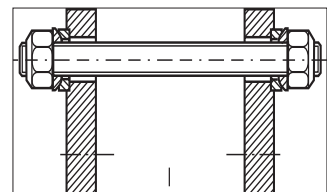

TRELLEBORG

www.trelleborg.com/fluidhandling