



RELIANCE EREL and ERES

User Manual

UM-3025 (RoW), Rev. 1.4.3, 2026-Apr-27



A.0 Disclaimer / Standard Warranty

CE certification

The equipment listed as CE certified means that the product complies with the essential requirements concerning safety and hygiene. The European directives that have been taken into consideration in the design are available on written request to ADB SAFEGATE.

ETL certification

The equipment listed as ETL certified means that the product complies with the essential requirements concerning safety and C22.2 No.180:13 (R2018) regulations. The CSA directives that have been taken into consideration in the design are available on written request to ADB SAFEGATE.

All Products Guarantee

ADB SAFEGATE will correct by repair or replacement per the applicable guarantee below, at its option, equipment or parts which fail because of mechanical, electrical or physical defects, provided that the goods have been properly handled and stored prior to installation, properly installed and properly operated after installation, and provided further that Buyer gives ADB SAFEGATE written notice of such defects after delivery of the goods to Buyer. Refer to the Safety section for more information on Material Handling Precautions and Storage precautions that must be followed.

ADB SAFEGATE reserves the right to examine goods upon which a claim is made. Said goods must be presented in the same condition as when the defect therein was discovered. ADB SAFEGATE further reserves the right to require the return of such goods to establish any claim.

ADB SAFEGATE's obligation under this guarantee is limited to making repair or replacement within a reasonable time after receipt of such written notice and does not include any other costs such as the cost of removal of defective part, installation of repaired product, labor or consequential damages of any kind, the exclusive remedy being to require such new parts to be furnished.

ADB SAFEGATE's liability under no circumstances will exceed the contract price of goods claimed to be defective. Any returns under this guarantee are to be on a transportation charges prepaid basis. For products not manufactured by, but sold by ADB SAFEGATE, warranty is limited to that extended by the original manufacturer. This is ADB SAFEGATE's sole guarantee and warranty with respect to the goods; there are no express warranties or warranties of fitness for any particular purpose or any implied warranties of fitness for any particular purpose or any implied warranties other than those made expressly herein. All such warranties being expressly disclaimed.

Standard Products Guarantee

Products manufactured by ADB SAFEGATE are guaranteed against mechanical, electrical, and physical defects (excluding lamps) which may occur during proper and normal use for a period of two years from the date of ex-works delivery, and are guaranteed to be merchantable and fit for the ordinary purposes for which such products are made.



Note

See your applicable sales agreement for a complete warranty description.

Replaced or repaired equipment under warranty falls into the warranty of the original delivery. No new warranty period is started for these replaced or repaired products.

FAA Certified products manufactured by ADB SAFEGATE

ADB SAFEGATE L858 Airfield Guidance Signs are warranted against mechanical and physical defects in design or manufacture for a period of 2 years from date of installation, per FAA AC 150/5345-44 (applicable edition).

ADB SAFEGATE LED products (with the exception of obstruction lighting) are warranted against electrical defects in design or manufacture of the LED or LED specific circuitry for a period of 4 years from date of installation, per FAA EB67 (applicable edition). These FAA certified constant current (series) powered LED products must be installed, interfaced and powered with and through products certified under the FAA Airfield Lighting Equipment Program (ALECP) to be included in this 4 (four) year warranty. This includes, but is not limited to, interface with products such as Base Cans, Isolation Transformers, Connectors, Wiring, and Constant Current Regulators.



Note

See your sales order contract for a complete warranty description.

Replaced or repaired equipment under warranty falls into the warranty of the original delivery. No new warranty period is started for these replaced or repaired products.

Liability



WARNING

Use of the equipment in ways other than described in the catalog leaflet and the manual may result in personal injury, death, or property and equipment damage. Use this equipment only as described in the manual.

ADB SAFEGATE cannot be held responsible for injuries or damages resulting from non-standard, unintended uses of its equipment. The equipment is designed and intended only for the purpose described in the manual. Uses not described in the manual are considered unintended uses and may result in serious personal injury, death or property damage.

Unintended uses, includes the following actions:

- Making changes to equipment that have not been recommended or described in this manual or using parts that are not genuine ADB SAFEGATE replacement parts or accessories.
- Failing to make sure that auxiliary equipment complies with approval agency requirements, local codes, and all applicable safety standards if not in contradiction with the general rules.
- Using materials or auxiliary equipment that are inappropriate or incompatible with your ADB SAFEGATE equipment.
- Allowing unskilled personnel to perform any task on or with the equipment.

Copyright Statement

This manual or parts thereof may not be reproduced, stored in a retrieval system, or transmitted, in any form or by any means, electronic, mechanical, photocopying, recording, nor otherwise, without the author's prior written consent.

This manual could contain technical inaccuracies or typographical errors. The author reserves the right to revise this manual from time to time in the contents thereof without obligation of the author to notify any person of such revision or change. Details and values given in this manual are average values and have been compiled with care. They are not binding, however, and the author disclaims any liability for damages or detriments suffered as a result of reliance on the information given herein or the use of products, processes or equipment to which this manual refers. No warranty is made that the use of the information or of the products, processes or equipment to which this manual refers will not infringe any third party's patents or rights. The information given does not release the buyer from making their own experiments and tests.

Table of Contents

1.0 Safety	1
1.1 Safety Messages.....	1
1.1.1 Introduction to Safety.....	2
1.1.2 Intended Use.....	2
1.1.3 Material Handling Precautions : Storage.....	3
1.1.4 Arc Flash and Electric Shock Hazard.....	3
2.0 About this manual	5
2.1 How to work with the manual.....	5
2.2 Abbreviations and terms — AGL	5
2.3 Abbreviations and terms - EREL and ERES.....	5
2.4 Identification on the fixture	6
3.0 Product Information RELIANCE EREL and ERES	7
3.1 Runway Edge, Stopway and Threshold / End	7
3.2 IQ function load (option).....	10
3.3 2A-system	11
3.4 Frangible coupling	11
3.5 Runway Threshold combined with Runway End fixtures.....	11
3.6 Monitoring (option)	12
3.7 Arctic kit (option).....	12
4.0 Installing and Replacing the Fixture	13
4.1 Inspection upon delivery	13
4.2 Storage	13
4.3 Installation	13
4.3.1 Intended Use.....	14
4.3.2 Preparation	14
4.3.3 Installation.....	15
4.3.4 Alignment guidelines	15
4.3.5 Install the alignment tool on the fixture	16
4.3.6 Leveling and alignment	17
4.3.7 Examination of the alignment	19
4.3.8 Finish.....	19
4.4 Removal.....	19
5.0 RELIANCE EREL and ERES Maintenance	21
5.1 Maintenance Safety.....	21
5.2 Preventive maintenance schedule	21
5.3 Part replacement.....	23
5.3.1 Part Replacement - Overview	23
5.3.2 Part Replacement - complete optical Head.....	24
5.3.3 Leveling and alignment	28
5.3.4 Part Replacement - optical Cover	30
5.3.5 Part Replacement - optical Kit.....	33
5.3.6 Part replacement - arctic kit (arctic kit option).....	38
5.3.7 Part Replacement - Light Body.....	42
5.3.8 Part Replacement - Cooling Block.....	45
5.3.9 Part Replacement - Body Support Assembly	48
5.3.10 Part Replacement - Cable Lead, Earthing Wire and Cable Bushing	50
5.3.11 Part Replacement - Frangible Coupling or Column.....	53
5.3.12 Repair a faulty Light (Monitoring Option).....	55
5.3.13 Part Replacement - Fuse Resistor (Monitoring Option).....	56
5.3.14 Assembling the complete optical head.....	57
5.3.15 Installing the Snow Rod Bracket (and Snow Rod).....	57
5.4 Fixture operation test	59
6.0 RELIANCE EREL and ERES Troubleshooting	61
6.1 Operation Safety.....	61
6.2 Troubleshooting guide.....	61
7.0 Spare Parts	63

7.1 Ordering Code EREL and ERES	63
7.2 Ordering Code	0
7.3 Exploded View	64
7.4 EREL and ERES Parts	65
7.5 Screws Overview	67
7.6 Options and Accessories	67
A.0 POWER TABLE	69
B.0 Cable Loss	71
C.0 Support	73
C.1 ADB SAFEGATE Website	74
C.2 Recycling	75
C.2.1 Local Authority Recycling	75
C.2.2 ADB SAFEGATE Recycling	75

List of Figures

Figure 1: Position installations.....	12
Figure 2: Fixture installation	15
Figure 3: Alignment tool installation.....	16
Figure 4: Leveling procedure	18
Figure 5: Alignment procedure.....	18
Figure 6: Tightening procedure	18
Figure 7: Alignment Examination	19
Figure 8: Alignment Examination 2	19
Figure 9: Removal procedure.....	20
Figure 10: Removal procedure - optical head	25
Figure 11: Installation procedure - part 1 - optical head	26
Figure 12: Installation procedure - part 2 - optical head	26
Figure 13: Leveling procedure	29
Figure 14: Alignment procedure.....	29
Figure 15: Tightening procedure	29
Figure 16: Optical cover removal	31
Figure 17: Optical cover installation - part 1	31
Figure 18: Optical cover installation - part 2.....	32
Figure 19: Optical cover installation - part 3.....	32
Figure 20: Removal procedure - part 1 - optical kit	35
Figure 21: Removal procedure - part 2 - optical kit	35
Figure 22: Removal procedure - part 3 - optical kit	36
Figure 23: Installation procedure - part 1 - optical kit.....	36
Figure 24: Installation procedure - part 2 - optical kit.....	37
Figure 25: Removal procedure - part 1 - arctic kit.....	39
Figure 26: Removal procedure - part 2 - arctic kit.....	40
Figure 27: Installation procedure - arctic kit.....	41
Figure 28: Removal procedure - light body.....	43
Figure 29: Removal procedure - part 1 - cooling block	46
Figure 30: Removal procedure - part 2 - cooling block	47
Figure 31: Installation procedure - cooling block.....	47
Figure 32: Removal procedure - body support assembly.....	48
Figure 33: Installation procedure - body support assembly	49
Figure 34: Removal procedure - part 1 - cable lead, earthing wire and cable bushing.....	51
Figure 35: Removal procedure - part 2 - cable lead, earthing wire and cable bushing.....	51
Figure 36: Installation procedure - cable lead, earthing wire and cable bushing	52
Figure 37: Removal procedure - frangible coupling	53
Figure 38: Installation procedure - frangible coupling.....	54
Figure 39: Disassembly - fuse resistor	56
Figure 40: Required Material	58
Figure 41: Mounting the Support Plate	58
Figure 42: Mounting the Snow Rod.....	59

List of Tables

Table 1: Troubleshooting guide.....	61
Table 2: Optical components	67

1.0 Safety

Introduction to Safety







This section contains general safety instructions for installing and using ADB SAFEGATE equipment. Some safety instructions may not apply to the equipment in this manual. Task- and equipment-specific warnings are included in other sections of this manual where appropriate.

1.1 Safety Messages

HAZARD Icons used in this manual

For all HAZARD symbols in use, see the Safety section. All symbols must comply with ISO and ANSI standards.

Carefully read and observe all safety instructions in this manual, which alert you to safety hazards and conditions that may result in personal injury, death or property and equipment damage and are accompanied by the symbols shown below.

	<p>WARNING</p> <p>Failure to observe a warning may result in personal injury, death or equipment damage.</p>
	<p>DANGER – Risk of electrical shock or ARC FLASH</p> <p>Disconnect equipment from line voltage. Failure to observe this warning may result in personal injury, death, or equipment damage. ARC Flash may cause blindness, severe burns or death.</p>
	<p>WARNING – Wear personal protective equipment</p> <p>Failure to observe may result in serious injury.</p>
	<p>WARNING – Do not touch</p> <p>Failure to observe this warning may result in personal injury, death, or equipment damage.</p>
	<p>CAUTION</p> <p>Failure to observe a caution may result in equipment damage.</p>
	<p>ELECTROSTATIC SENSITIVE DEVICES</p> <p>This equipment may contain electrostatic devices.</p>

Qualified Personnel

	<p>Important Information</p> <p>The term qualified personnel is defined here as individuals who thoroughly understand the equipment and its safe operation, maintenance and repair. Qualified personnel are physically capable of performing the required tasks, familiar with all relevant safety rules and regulations and have been trained to safely install, operate, maintain and repair the equipment. It is the responsibility of the company operating this equipment to ensure that its personnel meet these requirements.</p> <p>Always use required personal protective equipment (PPE) and follow safe electrical work practice.</p>
---	---

1.1.1 Introduction to Safety



CAUTION

Unsafe Equipment Use

This equipment may contain electrostatic devices, hazardous voltages and sharp edges on components

- Read installation instructions in their entirety before starting installation.
- Become familiar with the general safety instructions in this section of the manual before installing, operating, maintaining or repairing this equipment.
- Read and carefully follow the instructions throughout this manual for performing specific tasks and working with specific equipment.
- Make this manual available to personnel installing, operating, maintaining or repairing this equipment.
- Follow all applicable safety procedures required by your company, industry standards and government or other regulatory agencies.
- Install all electrical connections to local code.
- Use only electrical wire of sufficient gauge and insulation to handle the rated current demand. All wiring must meet local codes.
- Route electrical wiring along a protected path. Make sure they will not be damaged by moving equipment.
- Protect components from damage, wear, and harsh environment conditions.
- Allow ample room for maintenance, panel accessibility, and cover removal.
- Protect equipment with safety devices as specified by applicable safety regulations
- If safety devices must be removed for installation, install them immediately after the work is completed and check them for proper functioning prior to returning power to the circuit.

Failure to follow these instructions can result in serious injury, death or equipment damage

Additional Reference Materials



Important Information

- IEC – International Standards and Conformity Assessment for all electrical, electronic and related technologies.
- IEC 60364 – Electrical Installations in Buildings.
- CSA – C22.2 No.180:13 (R2018), series isolating transformers for airport lighting.
- FAA Advisory: AC 150/5340-26 (current edition), Maintenance of Airport Visual Aid Facilities.
- Maintenance personnel must refer to the maintenance procedure described in the ICAO Airport Services Manual, Part 9.
- ANSI/NFPA 79, Electrical Standards for Metalworking Machine Tools.
- National and local electrical codes and standards.

1.1.2 Intended Use



CAUTION

Use this equipment as intended by the manufacturer

This equipment is designed to perform a specific function, do not use this equipment for other purposes

- Using this equipment in ways other than described in this manual may result in personal injury, death or property and equipment damage. Use this equipment only as described in this manual.

Failure to follow this instruction can result in serious injury or equipment damage

1.1.3 Material Handling Precautions : Storage



CAUTION

Improper Storage

Store this equipment properly

- If equipment is to be stored prior to installation, it must be protected from the weather and kept free of condensation and dust.

Failure to follow this instruction can result in equipment damage

1.1.4 Arc Flash and Electric Shock Hazard



DANGER

SERIES CIRCUITS HAVE HAZARDOUS VOLTAGES

THIS EQUIPMENT PRODUCES HIGH VOLTAGES TO MAINTAIN THE SPECIFIED CURRENT - DO NOT DISCONNECT WHILE ENERGIZED.

- ALLOW ONLY QUALIFIED PERSONNEL TO PERFORM MAINTENANCE, TROUBLESHOOTING, AND REPAIR TASKS.
- ONLY PERSONS WHO ARE PROPERLY TRAINED AND FAMILIAR WITH ADB SAFEGATE EQUIPMENT ARE PERMITTED TO SERVICE THIS EQUIPMENT.
- AN OPEN AIRFIELD CURRENT CIRCUIT IS CAPABLE OF GENERATING >5000 VAC AND MAY APPEAR OFF TO A METER.
- NEVER UNPLUG A DEVICE FROM A CONSTANT CURRENT CIRCUIT WHILE IT IS OPERATING; ARC FLASH MAY RESULT.
- DISCONNECT AND LOCK OUT ELECTRICAL POWER.
- ALWAYS USE SAFETY DEVICES WHEN WORKING ON THIS EQUIPMENT.
- FOLLOW THE RECOMMENDED MAINTENANCE PROCEDURES IN THE PRODUCT MANUALS.
- DO NOT SERVICE OR ADJUST ANY EQUIPMENT UNLESS ANOTHER PERSON TRAINED IN FIRST AID AND CPR IS PRESENT.
- CONNECT ALL DISCONNECTED EQUIPMENT GROUND CABLES AND WIRES AFTER SERVICING EQUIPMENT. GROUND ALL CONDUCTIVE EQUIPMENT.
- USE ONLY APPROVED ADB SAFEGATE REPLACEMENT PARTS. USING UNAPPROVED PARTS OR MAKING UNAPPROVED MODIFICATIONS TO EQUIPMENT MAY VOID AGENCY APPROVALS AND CREATE SAFETY HAZARDS.
- CHECK THE INTERLOCK SYSTEMS PERIODICALLY TO ENSURE THEIR EFFECTIVENESS.
- DO NOT ATTEMPT TO SERVICE ELECTRICAL EQUIPMENT IF STANDING WATER IS PRESENT. USE CAUTION WHEN SERVICING ELECTRICAL EQUIPMENT IN A HIGH-HUMIDITY ENVIRONMENT.
- USE TOOLS WITH INSULATED HANDLES WHEN WORKING WITH AIRFIELD ELECTRICAL EQUIPMENT.

FAILURE TO FOLLOW THESE INSTRUCTIONS CAN RESULT IN DEATH OR EQUIPMENT DAMAGE

2.0 About this manual

The manual shows the information necessary to:

- Install
- Carry out maintenance
- Carry out troubleshooting on the RELIANCE Elevated Runway Edge Light, type EREL / ERES, in the manual referred to as the fixture.

2.1 How to work with the manual

1. Become familiar with the structure and content.
2. Carry out the actions completely and in the given sequence.

2.2 Abbreviations and terms — AGL

Acronym or Term	Description
FAA	Federal Aviation Administration
ICAO	International Civil Aviation Organization
IEC	International Electrical Committee
ISO	International Standardization Organization
ANSI	American National Standards Institute
NFPA	National Fire Protection Association
AC	Advisory Circular (FAA)
ESD	Electro-Static Discharge; Electrostatic-Sensitive Devices
LED	Light Emitting Diode
PPE	Personal Protective Equipment
FOD	Foreign Object Debris
Mounting support	A piece of equipment, on which the fixture is installed.
Toe-in	The toe-in angle is the angle the beam of light makes with the longitudinal axis of the runway or taxiway.

2.3 Abbreviations and terms - EREL and ERES

Acronym or Term	Description
C/L	Center Line
EREL	Elevated Runway Edge light, synthetic lens
ERES	Elevated Runway Edge light, glass lens
FAA	Federal Aviation Administration
FOD	Foreign Object Debris
ICAO	International Civil Aviation Organization
IEC	International Electrical Committee
ISO	International Standardization Organization
LED	Light Emitting Diode
Mounting support	A piece of equipment permanently installed on the ground, on which the fixture is installed with a frangible coupling device.
OAH	Overall Height
PCB	Printed Circuit Board
Toe-in	The toe-in angle is the angle the beam of light makes with the longitudinal axis of the runway or taxiway.

Acronym or Term	Description
TPI	Turns Per Inch
UNC	Unified Thread Standard

2.4 Identification on the fixture

A: Arrow. The arrow must always point to the center of the runway (CL).

B: ADB SAFEGATE logo.

C: Color of the optical cover. The color of the optical cover shows the color of the LEDs.

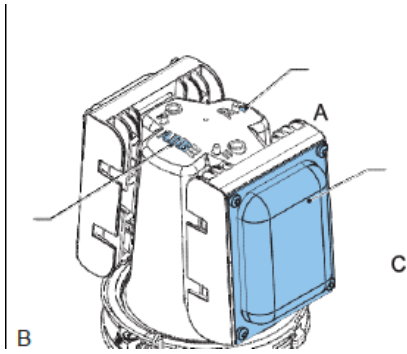

Note

Exception: the optical cover of the ICAO threshold is transparent and does not show the color of the LEDs.

3.0 Product Information RELIANCE EREL and ERES

3.1 Runway Edge, Stopway and Threshold / End

Compliance with Standards (current Versions)

FAA	L-862(L) and L-862E(L) AC 150/5345-46 and the FAA Engineering Brief No. 67; ETL certified
ICAO	Annex 14 Volume I
EASA	CS-ADR-DSN
NATO	STANAG 3316
Canada	TP 312
Australia	MOS 139

Uses

ICAO

- Runway Edge for runways up to 60 m wide
- Runway End
- Runway Threshold
- Runway Threshold / End
- Runway Stopway

FAA

- Runway Edge L-862(L)
- Runway End L-862E(L)
- Runway Threshold L-862E(L)
- Runway Threshold/End L-862E(L)

Features and Benefits

Available in three versions:

- RELIANCE® IQ with integrated ILCMS
- Monitored with integrated fail-open technology
- Non-Mon without monitoring functionality

Efficiency

- Very low energy consumption (typically 30 W for a bidirectional light, and 25 W for an unidirectional light, compared to 120, 150 or 200 W for tungsten halogen lights)
- Greatly reduced maintenance: calculated MTBF of 56,000 hours at 6.6A
- Fully dimmable lights, respecting the response curve of traditional halogen lights. Operates on the full range of 2.8 A to 6.6 A
- When turned on, light rise time is low. The light is perfectly adapted for any incursion protection system
- Optional monitoring function of the individual light source. In case of a defect, the LED light automatically disconnects from the secondary side of the isolation transformer, resulting in an open circuit condition
- Compatibility between RELIANCE IQ version and RELIANCE Intelligent Lighting 2A system for further power savings and ILCMS
- Leveling and aiming in azimuth of the fixture are easily performed with the dedicated aiming device
- Three screws allow a 4° leveling adjustment of the fixture after installation
- Upper body can be replaced without realignment of the fixture
- Omnidirectional beam for circling guidance is standard for bidirectional Runway Edge Fixture. Meeting minimum 50cd at 100% intensity. Note that the omni-directional LED follows the same dimming curve as the main beam.

Sustainability

- Installation on same mounting device as most elevated halogen lights, for a straightforward replacement
- Substantial investment reduction for new installations, resulting from a lower installed load
- Very low working temperature, ensuring longer component life
- Low-profile and small in size to withstand heaviest jet blast, even when installed at threshold/runway end
- Options for either glass or UV-resistant polycarbonate outer lens
- Use of LED light source eliminates filter replacement and color shifts when viewed at various angles or CCR step settings
- Sealed entry at cord set to optical assembly interface prevents insect entry. IP 66 protection degree
- Finishing: All hardware in stainless steel .The aluminum body phosphating with a baked polyester electrostatic powder coating, aviation yellow

Safety

- Increased availability of the runway thanks to the reduction of maintenance
- Optimum and homogeneous light distribution along the lights installed on the same runway
- High discrimination between functions thanks to the saturated colors, their stability at the different brightness steps and under all viewing angles
- Rugged lightning protection that complies with ANSI / IEEE C62.41 -1991 Location Category C2 given in FAA Eng. Brief 67. Category C2 is defined as a 1.2/50µS - 8/20 µS combination wave, with a peak voltage of 10,000 V and a peak current of 5.000 A

Accessories

Refer to the user manual for RELIANCE unidirectional and bidirectional elevated lights.

Aiming Device	1408.35.130
Snow Rod (10 pcs)	SP.4072.28.670

Power Supply

Non-MON and MON lights have been designed to work with any IEC- or FAA-compliant transformer up to 150 W. Refer to the user manual for calculation of actual circuit VA loads. IQ lights can work with transformers up 300W.



Note

- Refer to the appendix of user manual for RELIANCE unidirectional and bidirectional elevated lights for a complete power table and the cable loss formula.
- Refer to the annex.

Maintenance and Installation

Refer to the user manual for RELIANCE unidirectional and bidirectional elevated lights and to the interoperability info for installation in a specific base.

Dimensions and Weight

Outer diameter and height	166 × 233 mm / Without mounting interface
	6.54 × 9.17-in
Weight without packaging	3.36 kg /
	7.41 lb

Operating Conditions

Operating temperature	-67 to +131 °F / -50 to +55 °C
Storage temperature	-58 to +122°F / -50 to +50 °C
Relative humidity	Up to 100% condensing

Ordering Code

	Cover	Cable and Connectors	Color Left Side	Color Right Side	Toe-in ⁵	Overall Fixture Height / Coupling	Power Supply and Monitoring	Standard	Options	Arctic Kit	Enhanced Corrosion Resistance	Version
ERE	<input type="checkbox"/>	<input type="checkbox"/>	<input type="checkbox"/>	<input type="checkbox"/>	<input type="checkbox"/>	<input type="checkbox"/>	<input type="checkbox"/>	<input type="checkbox"/>	<input type="checkbox"/>	<input type="checkbox"/>	<input type="checkbox"/>	<input type="checkbox"/>

Cover

L = UV-resistant polycarbonate
S = Glass

Cable and Connectors

2 = 1 FAA L823 plug (2-pins)
6 = 1 plug (2-pins) w/Earth ground
8 = 1 external connected plug (2-pins)¹²

Color Left Side

W = White
R = Red
G = Green³⁴
Y = Yellow
N = None (Obscured)

Color Right Side

W = White
R = Red
G = Green³⁴
Y = Yellow
N = None (Obscured)

Toe-in⁵

0 = No toe-in⁴
1 = Left side with toe-in
2 = Right side with toe-in
3 = Both sides with toe-in

Overall Fixture Height / Coupling

1 = 14 in (35.6 cm) with 1.5" coupling, 12 TPI
2 = 20 in (50.8 cm) with 1.5" coupling, 12 TPI
3 = 24 in (61.0 cm) with 1.5" coupling, 12 TPI
5 = 14 in (35.6 cm) with 2" coupling, 11.5 TPI
6 = 20 in (50.8 cm) with 2" coupling, 11.5 TPI
7 = 24 in (61.0 cm) with 2" coupling, 11.5 TPI
9 = 14 in (35.6 cm) with 2" coupling, 11 TPI¹

Power Supply and Monitoring

S = 6.6A - 50/60 Hz series supply, without monitoring
M = 6.6A - 50/60 Hz series supply, with monitoring
P = IQ0 version⁶
Q = IQ1 version⁶

Standard

0 = ICAO- and FAA-compliant⁷
F = FAA (threshold only)
I = ICAO (threshold/end and threshold only)⁴
K = Australian (color to MOS 139)

Options

0 = No option
1 = With bracket for snow rod

Arctic Kit

0 = Without arctic kit
1 = With arctic kit⁸

Enhanced Corrosion Resistance

1 = Included

Version

2 = Improved mechanics

Ordering Code Notes

¹ Not defined by FAA, hence not ETL Certified.

² Cord set connected external to column.

³ G-green will only be delivered if Standard = K. All other applications will be delivered with F - green (ICAO / FAA).

⁴ ICAO / TP312 unidirectional threshold light is always without toe-in. These light fixtures have to be installed with a Toe-in to be compliant to the standards.

⁵ Refer to Toe-in Coding diagram for more information.

⁶ The IQ functionality allows control and monitoring of the fixture. IQ1 fixtures are preconfigured for the specific position at delivery. This function is disabled in IQ0 fixtures but could be enabled later.

⁷ All lights without green beam are compliant to ICAO and FAA. Use 0 for any application (FAA, ICAO, TP 312) that does not use green.

⁸ Not with IQ fixtures.



Note

Additionally please consider the following:

- Code for an ICAO unidirectional threshold light is ERE XX GN0 XX I XX12 , where X must be selected according to the table
- ICAO Stopway is always unidirectional, red and with toe-in
- White and yellow beams are for runway edge application and are always with toe-in
- Red beam may be with toe-in for runway edge application (e.g. displaced threshold) or without toe-in for runway end application
- Green beam is always with toe-in for FAA applications (See note 6 above for ICAO)

Toe-in Color Coding

For toe-in, the part number scheme assumes the observer is facing both the light and the runway centerline. For example, toe-in option 3 means that both the left and right side are toed in the direction of the centerline. If the equipment (A) has a toe-in (D), the toe-in is in compliance with the relevant ICAO or FAA requirements. The indication left side (L) or right side (R) always refers from the equipment to the centerline (C) of the runway (B).

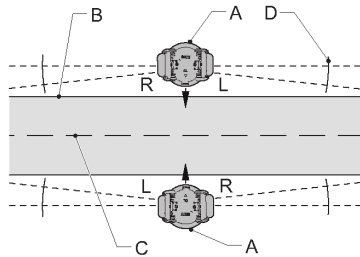

ANNEX

Fixture type	Fixture load	Isolation transformer			CCR load
		Rating	Loss	Efficiency	
without Arctic Kit:					
EREL (unidirectional)	29 VA	45 W	10 VA	0.85	39 VA
EREL (bidirectional)	33 VA	45 W	10 VA	0.85	43 VA
with Arctic Kit:					
ERES (unidirectional)	31 VA	45 W	10 VA	0.85	41 VA
ERES (bidirectional)	38 VA	45 W	10 VA	0.85	48 VA



Note

- Extra losses in secondary cables or due to extra equipment (e.g. ILCMS remotes) are not included in above table; these extra losses will result in a higher required size of isolation transformers
- Extra losses in primary cables are not included in above table; these extra losses will result in a higher required CCR load
- Efficiency of the secondary transformer depends on the supplier of secondary transformers

For more information about the product, including manuals, certifications and photometric data, please see our Product Center on the ADB SAFEGATE website, www.adbsafegate.com.

3.2 IQ function load (option)

With IQ enabled an additional capacity of 12 W need to be added to the transformer calculations for the powerline communication of the ILCMS. This has to be available for the communication to pass through without saturating the transformer (this power is not used and should not be included in the CCR calculation).



CAUTION

RELIANCE IQ is not to be connected to transformers smaller than 65 W.

3.3 2A-system

When dimensioning the isolation transformer size for a 2A-system, that is a series circuit with RELIANCE IQ 2A which is only supposed to run at 2A, it is important to know that the regular method by adding up the total wattage on the isolation transformer secondary side, cannot be used. This is because a standard isolation transformer 6.6A/6.6A is marked with a maximum wattage running at 6.6A. According to the Lenz Law of Induction, the dimensioning property of a transformer is the total voltage, and not the wattage, of the secondary side of the transformer in a 50/60Hz series circuit system.

The consequence in a 2A-system is the wattage marked on a 6.6A/6.6A isolation transformer must generally be multiplied by 3.3 (6.6/2) to find the total wattage which can be supplied from the transformer without saturating.



NOTICE

The same dimensioning method must be used for a CCR, as the transformer kVA-size marked on a CCR is normally calculated at 6.6A, not at 2A. There are also more constraints to consider such as spare capacity. For more information, contact ADB SAFEGATE for a complete CCR dimensioning procedure.

3.4 Frangible coupling

A: Frangible coupling

B: Weakening groove

C: Mounting flange A

The fixture includes a frangible coupling with a weakening groove.

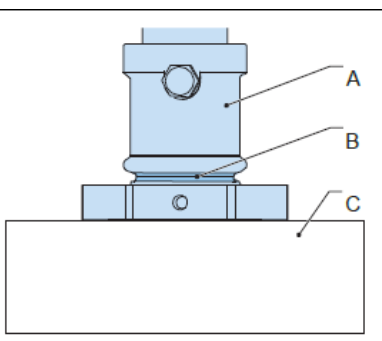

3.5 Runway Threshold combined with Runway End fixtures

If required the ICAO Runway Threshold / End position can be supplied either with two rows of unidirectional fixtures for each of the applications separately. Alternatively, it can be supplied with a bidirectional fixtures with both applications.

In the former case, the Threshold Green fixtures are not equipped with toe-in and shall be installed upon appropriate rotation of the fixture on the stem with respect to the mounting plate. In the latter case, only the centerline fixture has no toe-in on the green side. Positions displaced from the runway centerline shall be installed according to the scheme below, see [Figure 1](#).

Figure 1: Position installations

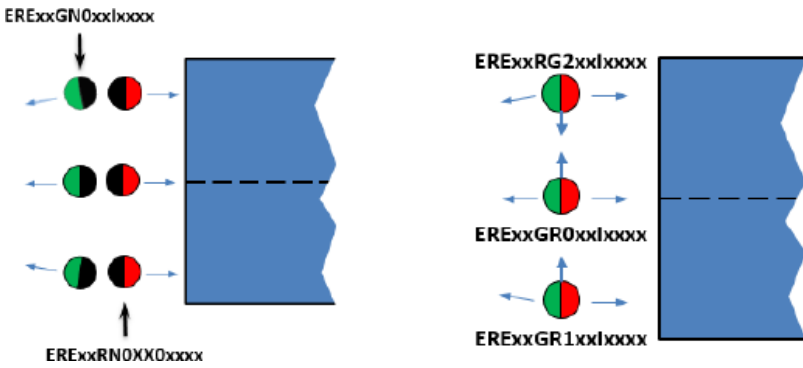

3.6 Monitoring (option)

The monitoring option is available. You can use the monitoring option with the Lamp Fault Detection of Constant Current Regulators or with Individual Light Control and Monitoring Systems (ILCMS) that check the status of the light by performing a continuity test on the secondary of the ILCMS remote unit. The monitoring option does a check on the light. In case of a failure of the light, the failure is detected by the electronics embedded in the light.



NOTICE

Ask your local representative for the compatibility of the ILCMS system and the light.

3.7 Arctic kit (option)

The arctic kit option is available, in compliance with FAA Engineering Brief EB67.

If the fixture has the arctic kit option, a thermostatically controlled heater prevents ice and snow buildup. This prevents a decrease of light output. This heater melts ice similar to traditional incandescent fixtures. The heater goes on only when the temperature drops below 0 degrees Celsius, to reduce the energy consumption.

The arctic kit is available on both glass and polycarbonate options.

4.0 Installing and Replacing the Fixture

The procedure only gives information on how to replace the complete fixture. For information on how to replace parts of the fixture, refer to [Part replacement](#) chapter.

4.1 Inspection upon delivery

1. Inspect all packing for visible damage.
2. Open every damaged box and inspect the contents for damage.
3. Immediately fill a claim form with the carrier if any equipment is damaged.
4. Store the equipment in its original packing in a protected area.



DANGER

DO NOT DAMAGE THE CABLE INSULATION.



IMPORTANT

Do not unpack the equipment before the equipment is at the installation site to avoid damage due to transportation and handling.

4.2 Storage

Store the fixture in its original packing in a protected area.

Indoor storage:

- Storage temperature: -55°C to +50°C (-67°F to 131°F).
- Humidity: <100% condensing.



Tip

For long storage periods (longer than one year), we recommend to energize the LED lights once a year at nominal intensity (6.6Amps) for 20 minutes.

4.3 Installation



DANGER

ONLY INSTALL THE FIXTURE ON MOUNTING SUPPORTS:

- THAT ADB SAFEGATE HAS APPROVED
- THAT ARE INSTALLED ACCORDING TO THE INSTRUCTION MANUAL OF THE MOUNTING SUPPORT
- FAILURE TO DO SO CAN RESULT IN A HIGHLY DANGEROUS SITUATION OF FOD, WITH POTENTIALLY LETHAL CONSEQUENCES
- DO NOT DAMAGE THE CABLE INSULATION
- MAKE SURE THE POWER TO THE SERIES CIRCUIT IS OFF WHEN YOU INSTALL OR REMOVE ANY FIXTURE.
- MAKE SURE THAT THE INSTALLATION, ALIGNMENT AND THE POSITION OF THE FIXTURE COMPLIES WITH FAA ADVISORY CIRCULAR AC 150/5340-30 (LATEST REVISION) AND ICAO ANNEX 14, VOLUME I, PARA 5.3.9 FOR RUNWAY EDGE LIGHTS.



NOTICE

Make sure that:

- The fixture is powered from a 6.6 A series circuit.
 - The series circuit is powered by a Constant Current Regulator that complies with IEC 61822 or FAA AC 5345-10 (latest revision).
 - The transformer is series isolation transformer that complies with IEC 61823 or FAA AC 5345-47 (latest revision); the power of the series transformer shall not exceed 200 W. This does not apply for IQ or IQ 2A installations where larger transformers can or should be used. Please contact your sales representative for more information.
 - The mounting support is correctly earthed. Failure to do so will void the warranty for all damages that occur as a result of voltage surges.
-



Note

Refer to the User Manual for the mounting support for instructions on how to earth the mounting support.

Parts:

- Complete fixture

Tools:

- Open spanners
- Alignment tool

4.3.1 Intended Use



CAUTION

Use this equipment as intended by the manufacturer

This equipment is designed to perform a specific function, do not use this equipment for other purposes

- Using this equipment in ways other than described in this manual may result in personal injury, death or property and equipment damage. Use this equipment only as described in this manual.

Failure to follow this instruction can result in serious injury or equipment damage

4.3.2 Preparation

1. Make sure that the fixture is completely assembled.
 2. Make sure that the fixture is operationally tested.
-



Note

Refer to [Fixture Operating Test](#) section.

4.3.3 Installation

Figure 2: Fixture installation

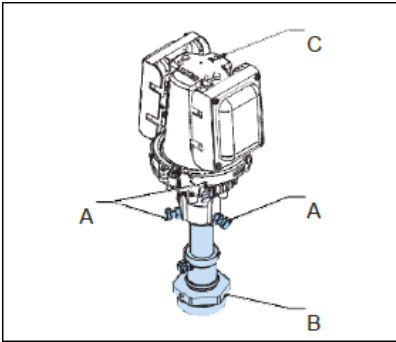

1. Connect the plug to the receptacle of the transformer.
2. If the fixture has a separate earth ground wire, connect it.
3. Loosen the screws (A).
4. Place the fixture on the mounting support.
5. Turn in the frangible coupling (B).



Note

Do not turn the body support.

6. Tighten the frangible coupling (B) to the mounting support.
Use an open spanner that fits the hexagon of the frangible coupling.
7. Make sure the arrow (C) points to the center of the runway.

4.3.4 Alignment guidelines

The fixture is aligned in azimuth by looking at a reference mark through the alignment tool. Depending on the position of the fixture, the reference mark may be another light in the same row or a stick installed for this purpose. Usually, for runway edge lights another light of the same row is used. For threshold and runway end lights, a stick can be installed in the prolongation of the threshold and runway end lights line.

4.3.5 Install the alignment tool on the fixture



Note

The alignment tool can be installed in four directions.

The direction of installation is dependent on the position of the reference mark you have chosen.

Figure 3: Alignment tool installation

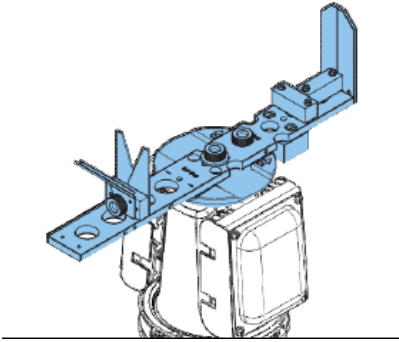

Install the alignment tool in the desired direction on top of the fixture.



CAUTION

Make sure that the center line mark of the fixture and the alignment tool point towards the runway.

4.3.6 Leveling and alignment

Level the fixture

1. Move the fixture until it is level and hold it there. Examine the spirit levels (A) and (B).

Figure 4: Leveling procedure

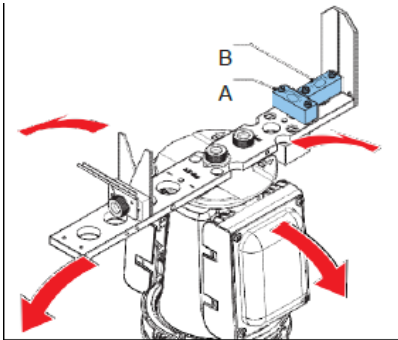

Align the fixture

1. From the top down, look into the mirror (A) and turn the fixture until it aligns with the other fixtures (B).
2. Hold the fixture in this position.
3. Examine again if the fixture is level.



Tip

Do not tighten the screws on the stem until the adjustment is finished.

Figure 5: Alignment procedure

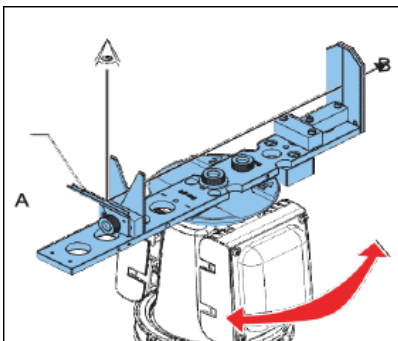

Finish

1. Tighten the alignment screws (A) gradually. Refer to the [Screws Overview](#) section (torque).



NOTICE

Tighten the alignment screws progressively to the correct torque.

Figure 6: Tightening procedure

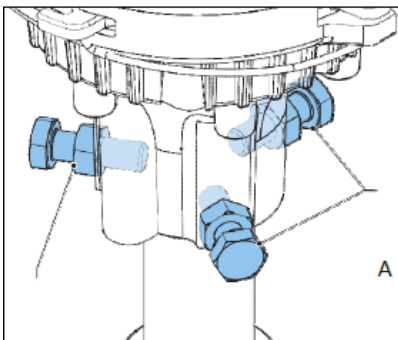

4.3.7 Examination of the alignment

Examine

1. Install the alignment tool.



Note

Refer to the [Install the Alignment Tool](#) section.

2. Look from the top down into the mirror (A).
3. Examine the spirit levels (B) and (C).
4. If the alignment is not correct or if the fixture is not level, align or level the fixture.



Note

Refer to the [Level the Alignment Tool](#) section.

Figure 7: Alignment Examination

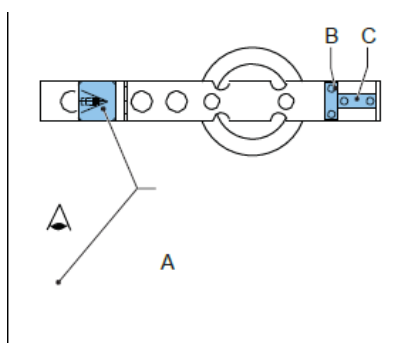

Finish

1. Remove the alignment tool.
2. Make sure that the arrow (A) points to the runway center of the .

Figure 8: Alignment Examination 2

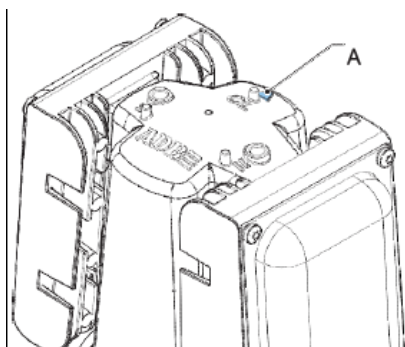

4.3.8 Finish

1. Examine the color of each lens.
2. Examine the toe-in.

4.4 Removal

Tools:

- Open spanner 50 mm
1. Loosen the nuts (A) and the screws (B).

- Loosen the frangible coupling (C).



NOTICE

Do not turn the body support.

- Disconnect the plug (D).
- If the fixture has a separate earth ground wire, disconnect it.

Figure 9: Removal procedure

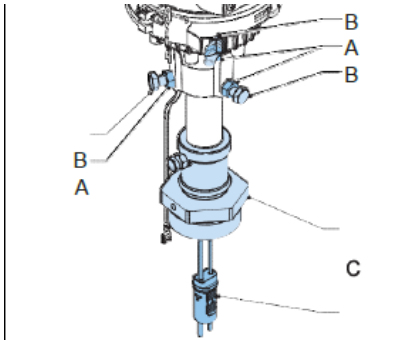

5.0 RELIANCE EREL and ERES Maintenance

Maintenance personnel must refer to the maintenance procedure described in the ICAO Airport Services Manual, Part 9, Airport maintenance practices and in FAA Advisory Circular N° AC150/5340-26.



WARNING

Do not carry out any action on the fixture unless you have read and understood all the information in the [Safety](#) and [Product Information RELIANCE EREL and ERES](#) chapters as well as the [Maintenance Safety](#) section of this chapter.



DANGER

MAKE SURE THAT THE POWER TO THE SERIES CIRCUIT IS OFF WHEN YOU CARRY OUT MAINTENANCE.

5.1 Maintenance Safety



DANGER



ELECTRIC SHOCK HAZARD





THIS EQUIPMENT MAY CONTAIN ELECTROSTATIC DEVICES

- DO NOT OPERATE A SYSTEM THAT CONTAINS MALFUNCTIONING COMPONENTS. IF A COMPONENT MALFUNCTIONS, TURN THE SYSTEM OFF IMMEDIATELY.
- DISCONNECT AND LOCK OUT ELECTRICAL POWER.
- ALLOW ONLY QUALIFIED PERSONNEL TO MAKE REPAIRS OR REPLACE MALFUNCTIONING COMPONENTS ACCORDING TO INSTRUCTIONS PROVIDED IN MANUAL.

FAILURE TO FOLLOW THESE INSTRUCTIONS CAN RESULT IN DEATH OR EQUIPMENT DAMAGE

5.2 Preventive maintenance schedule

Interval	Check	Action
Daily	For low light output according to ICAO annex 14	<ol style="list-style-type: none"> 1. If the optical cover is dirty, clean the optical cover. If the optical cover is not dirty, replace the complete optical head. 2. Replace the faulty component in the workshop. <div style="border: 1px solid black; padding: 5px; margin-top: 10px;">  <p>Note Refer to the Part replacement and the Troubleshooting chapters.</p> </div>
Weekly	For contamination	Clean the fixture.
Monthly	<p>Visually for condensation on the inner side of the optical cover (presence of moisture or water)</p> <p>Condensation is an acceptable phenomenon, as long as it disappears when the equipment is in use.</p>	<p>Turn on the fixture for 30 minutes. In case the condensation has not disappeared:</p> <ol style="list-style-type: none"> 1. Remove the optical cover. 2. Clean and dry the optical cover. 3. Replace the optical cover gasket. 4. Install the dry optical cover. <div style="border: 1px solid black; padding: 5px; margin-top: 10px;">  <p>Note Refer to the Optical Cover Replacement section.</p> </div>

Interval	Check	Action
	For failed fixture	<ol style="list-style-type: none"> 1. Replace the complete optical head. 2. Replace the faulty component in the workshop. <hr/>  Note Refer to the Part replacement and the Troubleshooting chapters.
Semi-annually	For presence of water at the inside of the fixture	<ol style="list-style-type: none"> 1. Remove the optical cover 2. Dry and clean the optical cover. 3. Replace the optical cover gasket. 4. Install the dry optical cover.
	For correct alignment and if the fixture is level.	Adjust the alignment or level the fixture. <hr/>  Note Refer to the Alignment Examination section.
	For correct torque of alignment screws and frangible coupling to column screws	<hr/>  Note Refer to Figure 15 : Tightening procedure
	For damaged paint	<ol style="list-style-type: none"> 1. Clean the fixture. 2. Paint the fixture again.
Yearly	For cracks, corrosion or short circuit	Clean the fixture and replace faulty or corroded parts. <hr/>  Note Refer to the Troubleshooting chapter.
	For dirty contacts	<ol style="list-style-type: none"> 1. Make sure that the power is OFF. 2. Clean the contact.
	For loose connections	Tighten or repair the connection.
	Torque	Verify torque (2.5 Nm) on screws retaining the optical cover cartridge.
After snow removal	For damaged fixture.	<ol style="list-style-type: none"> 1. Remove any debris or left over parts. 2. Install a new fixture. 3. Use a power broom to remove the snow near the fixture, if practical. 4. Follow the recommended snow removal techniques described in FAA AC 150/5200-23 to avoid or at least to reduce damage to the fixture. <hr/>  Note Refer to the Installation chapter.

5.3 Part replacement



Fastpath

Except for the optical head, all replacements must be done in the workshop. To remove the complete fixture, refer to [Removal](#) section.

5.3.1 Part Replacement - Overview

This section gives you an overview of the replacement chapter sections.

1. Replacement of different parts:
 - Optical head: Refer to [Part Replacement - complete optical Head](#).
 - Optical cover: Refer to [Part Replacement - optical Cover](#).
 - Optical kit: Refer to [Part Replacement - optical Kit](#).
 - Arctic kit (arctic kit option): Refer to [Part replacement - arctic kit \(arctic kit option\)](#).
 - Body: Refer to [Part Replacement - Light Body](#).
 - Cooling block: Refer to [Part Replacement - Cooling Block](#).
 - Body support assembly: Refer to [Part Replacement - Body Support Assembly](#).
 - Cable lead, Earthing wire and cable strain relief bushing: Refer to [Part Replacement - Cable Lead, Earthing Wire and Cable Bushing](#).
 - Frangible coupling: Refer to [Part Replacement - Frangible Coupling or Column](#).
 - Repair a faulty light (monitoring option): Refer to [Repair a faulty Light \(Monitoring Option\)](#).
 - Fuse resistor (monitoring option): Refer to [Part Replacement - Fuse Resistor \(Monitoring Option\)](#).
2. Other procedures:
 - Assembling the complete optical head: Refer to [Assemble the Optical Head](#)
 - Repairing a faulty light (monitoring option): Refer to [Repair a faulty Light \(Monitoring Option\)](#).
 - Installing a snow rod bracket (and snow rod): Refer to [Installing the Snow Rod Bracket \(and Snow Rod\)](#).

5.3.2 Part Replacement - complete optical Head



Note

The replacement procedure of the complete optical head can be done in the field.
Refer to the [Exploded View](#) section for information on parts.

- The optical head consists of the following components:
 - Body
 - Optical kit
 - LED MCPCB screws
 - Optical cover
 - Cover fixation clip
 - Optical cover gasket
 - Cooling block
 - Cooling block gasket
 - Flat washers
- Body gasket



Note

Refer to the [Assemble the Optical Head](#) section.

Removal procedure

1. Remove the safety pins (A): Refer to I in the figure below.
2. Open the body support clip (B): Refer to II to IV in the figure below.
3. Carefully remove the complete optical head (C).
4. Disconnect the cable leads and the earthing wire, if it is connected (D).



WARNING

Before you disconnect the wires, earth the complete optical head.

5. Remove the body gasket (E).
6. Dispose of the body gasket.

Figure 10: Removal procedure - optical head

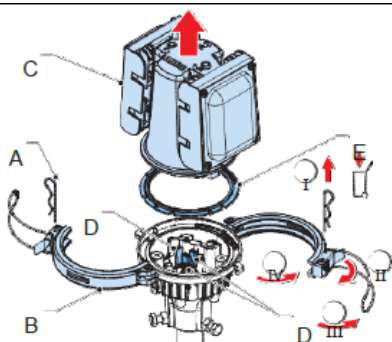

Preparation for installation

1. Make sure that all the parts are clean.
 2. Pay special attention to the parts where the gasket must fit.
 3. Assemble the complete optical head.
-



Note

Refer to the [Assemble the Optical Head](#) section.

Installation - Step 1

1. Install the new gasket (A). Make sure that the side marked 'THIS SIDE TO CENTER LINE' is at the side that corresponds with the arrow on the optical head.
2. Connect the cable leads to the connectors (B): 'IN1' and 'IN2'.
3. If you use an Earthing wire, connect it to the connector (C): 'PE'.

Figure 11: Installation procedure - part 1 - optical head

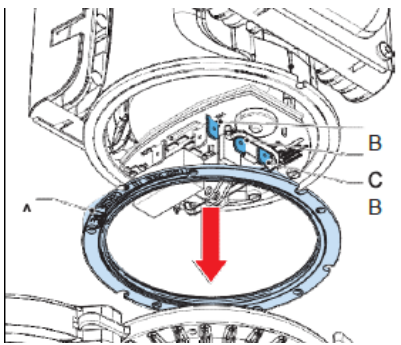

Installation - Step 2

1. Put the complete optical head (A) on the support (B).
2. Make sure that the rims (C) fit into the gaps (D).
3. Make sure that the arrow (E) points to the center of the runway.
4. Close the clamps (F) of the body support clip: Refer to I to III in the figure below. Make sure that the rim (G) of the optical head is completely inside the rims of the body support clip.

Figure 12: Installation procedure - part 2 - optical head

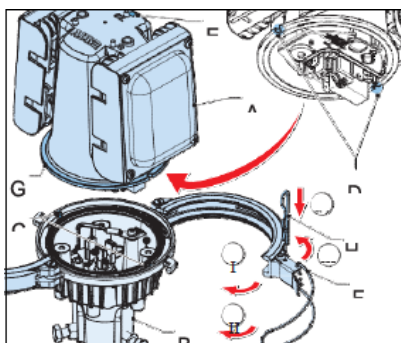

IMPORTANT

The body support clip must tighten the optical head to avoid risk of FOD caused by a loose head assembly.

5. Install the safety pins (H): Refer to IV in the figure below.

-
6. Verify that the light turns on when powered.
-



IMPORTANT

Do not damage the cable lead.

5.3.3 Leveling and alignment

Level the fixture

1. Move the fixture until it is level and hold it there. Examine the spirit levels (A) and (B).

Figure 13: Leveling procedure

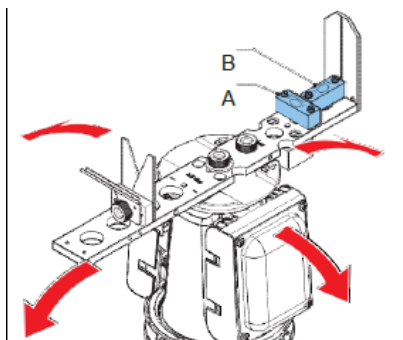

Align the fixture

1. From the top down, look into the mirror (A) and turn the fixture until it aligns with the other fixtures (B).
2. Hold the fixture in this position.
3. Examine again if the fixture is level.



Tip

Do not tighten the screws on the stem until the adjustment is finished.

Figure 14: Alignment procedure

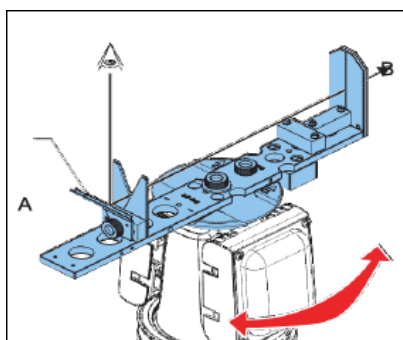

Finish

1. Tighten the alignment screws (A) gradually. Refer to the [Screws Overview](#) section (torque).



NOTICE

Tighten the alignment screws progressively to the correct torque.

Figure 15: Tightening procedure

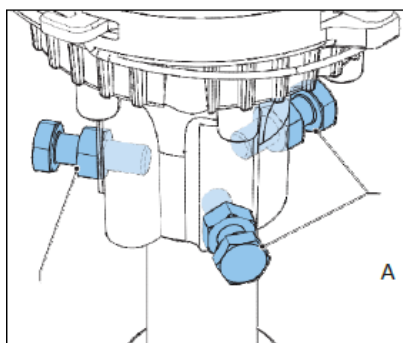

5.3.4 Part Replacement - optical Cover



Note

Refer to the [Exploded View](#) section for information on parts.

- Optical cover
- Clip for optical cover
- Optical cover gasket

Tools:

- Screwdriver, Torx T20

Removal

1. Remove the screws for the optical cover clip and washers (A).
2. Remove the clip (B).
3. Remove the spacer (C).
4. Remove the optical cover (D).
5. Remove the optical cover gasket (E).
6. Dispose of the optical kit screws and washers.
7. Dispose of the optical cover gasket.

Figure 16: Optical cover removal

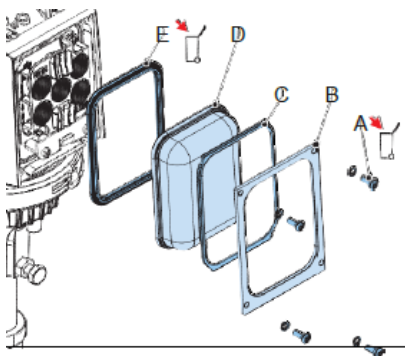

Installation - Step 1

1. Make sure that all the parts are clean.
Pay extra attention to the parts where the optical cover gasket must fit.
2. Install the new optical cover gasket (A) onto the new optical cover (B).

Figure 17: Optical cover installation - part 1

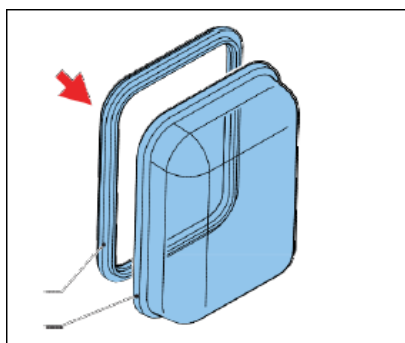

Fastpath

Make sure that the bulges of the optical cover gasket fit smoothly into the grooves of the cooling block and the grooves of the optical cover. The optical cover gasket is not symmetrical.

3. Install the new optical cover.

4. Make sure that the color of the optical cover matches the color of the sticker on the LED MCPCB. Exception: the ICAO threshold has a transparent cover.

Installation - Step 2

1. Keep the optical cover (A) pressed against the head assembly (B).

Figure 18: Optical cover installation - part 2

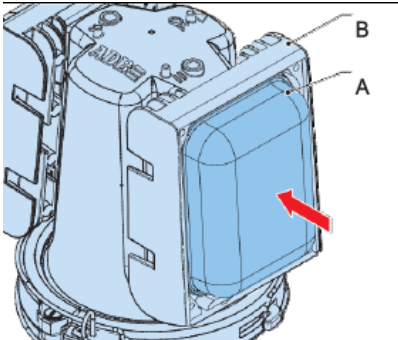

Installation - Step 3

1. Install the spacer (A) and the clip (B).



IMPORTANT

Do not forget to re-install the spacer between the cover and the clip, if the fixture or the new clip has been supplied with a spacer (and always for fixtures with glass covers),

2. Make sure that the smaller side of the spacer is on top.



Fastpath

The spacer is not rectangular. Install the spacer correctly.

3. Install the washers and the screws for the optical cover clip (C).



Note

Refer to the [Screws Overview](#) section (torque).

Figure 19: Optical cover installation - part 3

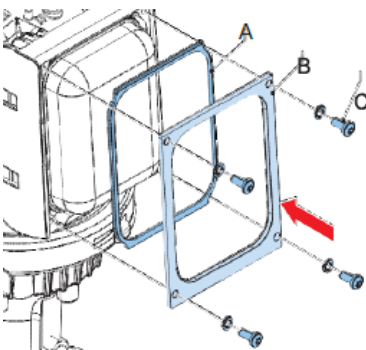

5.3.5 Part Replacement - optical Kit



Note

Refer to [Exploded View](#) for information on parts.

- Optical kit:
 - LED MCPCB
 - Optical block
 - Protection rings
 - Optical cover gasket
 - Body gasket
-



CAUTION

The cooling block for the FAA L-862E green differs from the cooling block used for all other applications. If you modify a fixture into or from FAA L-862E green from or into another function, also change the cooling block.



Note

The LED MCPCB and the optical block are supplied as a kit, complete with all components for replacement, i.e. screws.

Tools:

- Screwdriver, Torx T20

Prepare



Tip

Do not mix optical blocks and LED MCPCBs from different deliveries. The optical blocks can change due to the future evolution of the available LEDs.

Remove - Step 1

1. Remove the complete optical head.
-



Note

Refer to [Part Replacement - complete optical Head](#) section.

2. Put the complete optical head on a clean surface.
3. Make sure that the complete optical head is earthed.
4. Connect the earth to the connector (A): PE. The PCBs will discharge.

- Remove the optical cover.



Note

Refer to [Part Replacement - optical Cover](#) section.

Figure 20: Removal procedure - part 1 - optical kit

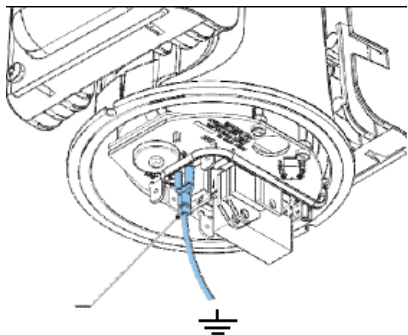

Remove - Step 2

- Remove the optical block screws (A) and washers (B).
- Dispose of the screws and the washers.
- Remove the optical block (C).
- Dispose of the optical block.
- Remove the protection rings (D), if present.
- Dispose of the protection rings.

Figure 21: Removal procedure - part 2 - optical kit

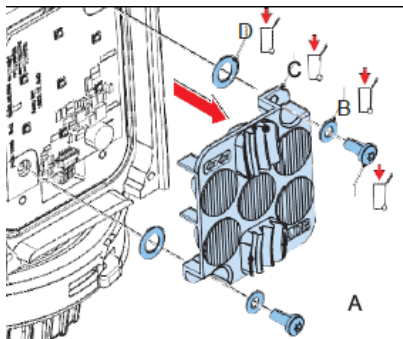

Remove - Step 3

- Disconnect the connector (A).
- Remove the LED MCPCB (B).

3. Dispose of the LED MCPCB.

Figure 22: Removal procedure - part 3 - optical kit

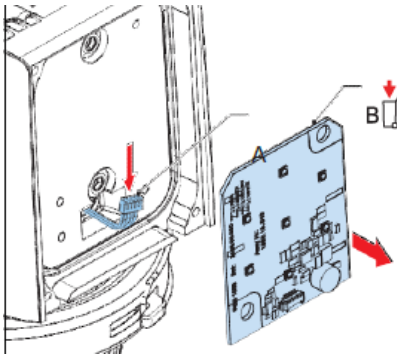

Install - Step 1

1. Read the instructions supplied with the parts for the correct installation of the new parts on the cooling block.



CAUTION

Do not touch the LEDs.

2. Make sure that all the parts are clean.
3. Make sure that the rear side of the new LED MCPCB (A) is clean. The heat dissipation must be maximized.
4. Put the LED MCPCB tightly against the cooling block (B). The heat dissipation must be maximized.
5. Connect the connector (C).

Figure 23: Installation procedure - part 1 - optical kit

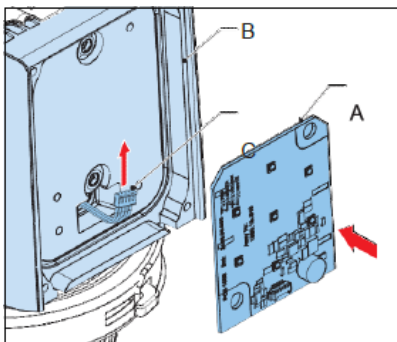

NOTICE

- On one side there is an additional connector. This connector is used for service and diagnostic and is marked with a black dot. Do not connect the LED MCPCB to the connector with the black dot.
- On fixtures with an arctic kit there is an additional connector for the connection of the arctic kit. This connector has 4 poles. Connect the cable with the connector with 5 poles to the LED MCPCB.

Install - Step 2

1. Install the new protection rings (A), only if protection rings are delivered with the new optical kit.
2. Install the new optical block (B).
3. Make sure that the feet of the optical block fit in the cutouts of the LED MCPCB.
4. Install the new washers (C) and the new optical block screws (D).



Note

Refer to [Screws Overview](#) (torque).

5. Install the optical cover.



Note

Refer to [Part Replacement - optical Cover](#) section.

Figure 24: Installation procedure - part 2 - optical kit

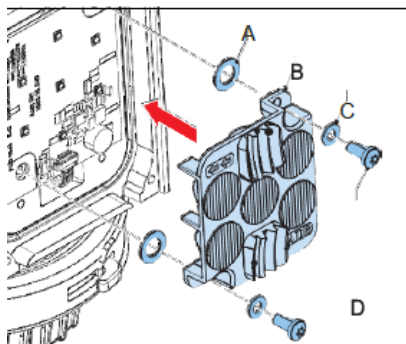

5.3.6 Part replacement - arctic kit (arctic kit option)



Note

Refer to [Exploded View](#) section for more information.

- Arctic kit, including spacers and screws
- Optical cover gasket
- Body gasket



Note

The arctic kit is supplied as a kit, complete with all components for replacement i.e. screws.

Tools:

- Screwdriver, cross

Removal - Step 1

1. Remove the complete optical head.



Note

Refer to [Part Replacement - complete optical Head](#) section.

2. Put the complete optical head on a clean surface.
3. Make sure that the complete optical head is earthed. Connect the earth to the connector (A): PE. The PCBs will discharge.
4. Remove the optical cover.



Note

Refer to [Part Replacement - optical Cover](#) section.

Figure 25: Removal procedure - part 1 - arctic kit

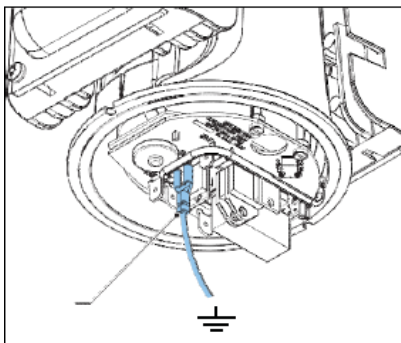

Removal - Step 2

1. Disconnect the connector (A).
2. Remove the arctic kit screws (B).
3. Remove the PCB of the arctic kit (C).
4. Remove the spacers (D).

5. Dispose of these parts:
 - a. arctic kit screws
 - b. PCB of the arctic kit
 - c. spacers

Figure 26: Removal procedure - part 2 - arctic kit

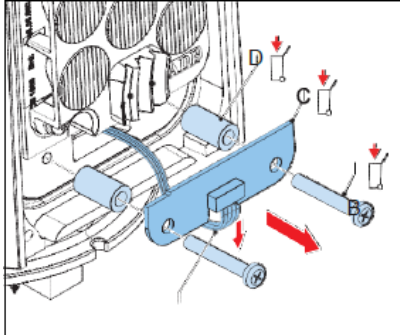

Installation

1. Apply adhesive on the first three threads of the threaded holes of the cooling block. Use adhesive D.
-



Note

Refer to [Options and Accessories](#) section.

2. Install the new spacers (A).
 3. Install the new PCB of the arctic kit (B).
 4. Install the new arctic kit screws (C).
-



Note

Refer to [Screws Overview](#) section (torque).

5. Connect the cable with 4 poles to connector (D).
-



Note

There are one or two additional connector(s) for the connection of the LED MCPCB and for service and diagnostic. Those connectors have 5 poles.

6. Install the optical cover.
-



Note

Refer to [Part Replacement - optical Cover](#) section.

7. Install the complete optical head.



Note

Refer to [Part Replacement - complete optical Headsection](#).

Figure 27: Installation procedure - arctic kit

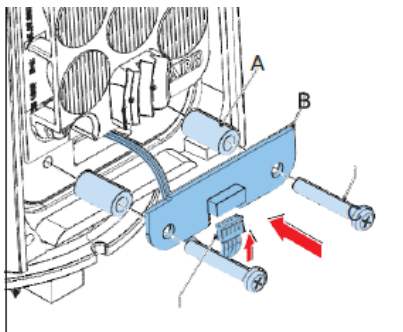

5.3.7 Part Replacement - Light Body



Note

Refer to [Exploded View](#) section for more information on parts.

- Body
- Optical cover gasket
- LED MCPCB screws
- Body gasket
- Cooling block gasket

Tools:

- Screwdriver, Torx T25

Removal

1. Remove the complete optical head.



Note

Refer to [Part Replacement - complete optical Head](#) section.

2. Put the complete optical head on a clean surface.
3. Make sure that the complete optical head is earthed. Connect the earth to the connector (A): PE. The PCBs will discharge.
4. Remove the optical cover.



Note

Refer to [Part Replacement - complete optical Head](#) section.

5. Remove the optical kit.



Note

Refer to [Part Replacement - optical Kit](#) section.

6. Remove the cooling block.



Note

Refer to [Part Replacement - complete optical Head](#) section.

Figure 28: Removal procedure - light body

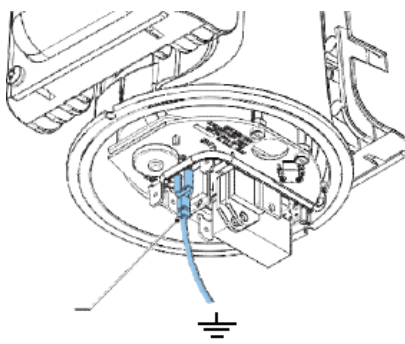

Installation

1. Install the cooling block on the new body.



Note

Refer to [Part Replacement - Cooling Block](#) section.

2. Install the optical kit on the cooling block.
-



Note

Refer to [Part Replacement - optical Kit](#) section.

3. Install the optical cover.
-



Note

Refer to [Part Replacement - optical Cover](#) section.

4. Install the complete optical head.
-



Note

Refer to [Part Replacement - complete optical Head](#) section.

5.3.8 Part Replacement - Cooling Block



Note

Refer to [Exploded View](#) section for more information on parts.

- Cooling block
- Cooling block gasket
- Optical cover gasket

Tools:

- Screwdriver, Torx T25

Removal - Step 1

1. Remove the complete optical head.
-



Note

Refer to [Part Replacement - complete optical Head](#) section.

2. Put the complete optical head on a clean surface.
 3. Make sure that the complete optical head is earthed. Connect the earth to the connector (A): PE. The PCBs will discharge.
 4. Remove the optical cover.
-



Note

Refer to [Part Replacement - optical Cover](#) section.

5. Remove the optical kit.
-



Note

Refer to [Part Replacement - optical Kit](#) section.

Figure 29: Removal procedure - part 1 - cooling block

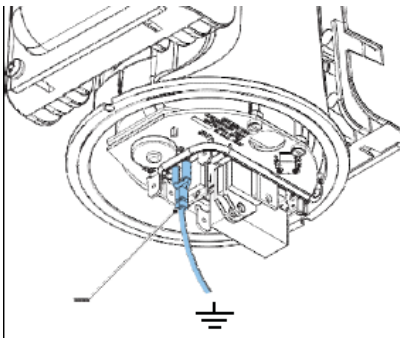

Removal - Step 2

1. Remove the cooling block screws (A) and washers (B).
2. Dispose of the cooling block screws and washers.
3. Remove the cooling block (C).
4. Remove the cooling block gasket (D).

5. Dispose of the cooling block gasket.

Figure 30: Removal procedure - part 2 - cooling block

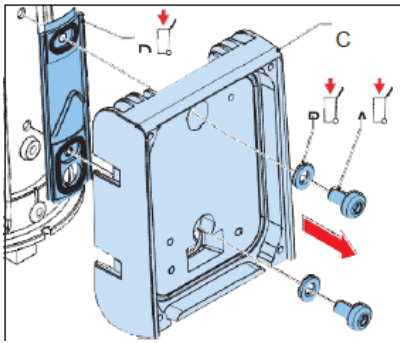

Installation - Step 1

1. Make sure that all the parts are clean. Pay extra attention to the parts where the cooling block gasket must fit.
2. Apply adhesive on the first three threads of the threaded holes in the body. Use adhesive C. See [Options and Accessories](#).
3. Install the new cooling block gasket (A) on the body (B).
4. Install the new cooling block (C).
5. Push the cooling block towards the arrow to the center line (D).
6. Install the washers (E) and the cooling block screws (F). See [Screws Overview](#) (torque).
7. Make sure that the cooling blocks on both sides of the fixture are parallel to each other.

Installation - Step 2

1. Install the optical kit. See [Part Replacement - optical Kit](#).
2. Install the optical cover. See [Part Replacement - optical Cover](#).
3. Install the complete optical head. See [Part Replacement - complete optical Head](#)

Figure 31: Installation procedure - cooling block

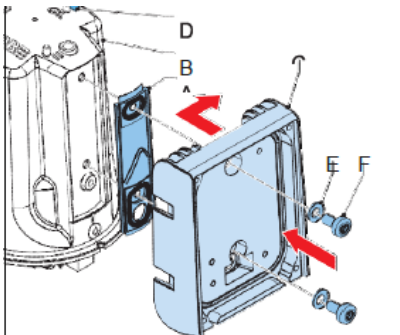

5.3.9 Part Replacement - Body Support Assembly



Note

Refer to [Exploded View](#) section for more information on parts.

- Body support assembly
- Body gasket

Tools:

- Spanner, size 13

Removal

1. Remove the complete optical head.
-



Note

Refer to [Part Replacement - complete optical Head](#) section.

2. Remove the alignment screws (A).
 3. Remove the body support assembly (B).
 4. If necessary, remove the cable lead, the Earthing wire and de cable strain relief bushing.
-



Note

Refer to [Part Replacement - Cable Lead, Earthing Wire and Cable Bushing](#) section.

Figure 32: Removal procedure - body support assembly

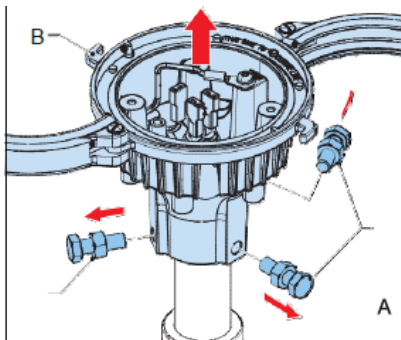

Installation

1. Install the cable lead, the Earthing wire and the cable strain relief bushing — if necessary.
-



Note

Refer to [Part Replacement - Cable Lead, Earthing Wire and Cable Bushing](#) section.

2. Install the new body support assembly (A).
3. Install but do not tighten the alignment screws (B).

4. Install the complete optical head.



Note

Refer to [Part Replacement - complete optical Head](#) section.

Figure 33: Installation procedure - body support assembly

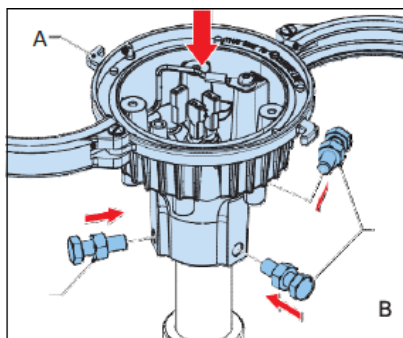

5.3.10 Part Replacement - Cable Lead, Earthing Wire and Cable Bushing



Note

Refer to [Exploded View](#) section for more information on parts.

- Body gasket
- Cable lead
- Earthing cable
- Cable strain relief bushing

Tools:

- Pliers
- Screwdriver, Torx T20



Note

The steps for the Earthing cable only apply if one is installed.

Removal - step 1

1. Remove the complete optical head.



Note

Refer to [Part Replacement - complete optical Head](#) section.

2. Compress the cable strain relief bushing (A) and pull it out of the body support (B). *Use the pliers.*
3. Remove the screw (C) for the Earthing cable.

Figure 34: Removal procedure - part 1 - cable lead, earthing wire and cable bushing

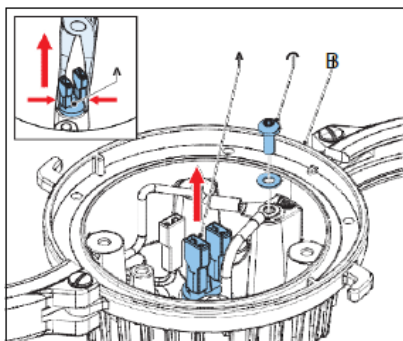

Removal - step 2

1. Open the cable strain relief bushing (A).
2. Pull the cable lead (C) and the Earthing wire (B) out of the fixture.
3. Dispose of the damaged parts.

Figure 35: Removal procedure - part 2 - cable lead, earthing wire and cable bushing

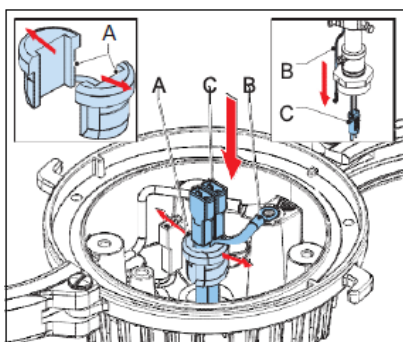

Installation

1. Pull the cable lead (A) and the Earthing cable (B) through the hole (C) of the body support.
 2. Put the cable lead and the Earthing cable in the cable strain relief bushing (D): I.
 3. Install the Earthing cable on the screw for the Earthing cable (E).
 4. Install the screw for the Earthing cable.
-



Note

Refer to [Screws Overview](#) (torque) section.

5. Compress the cable strain relief bushing and insert it in the hole of the body support : II. *Use the pliers.*
 6. Install the complete optical head.
-



Note

Refer to [Part Replacement - complete optical Head](#) section.

Figure 36: Installation procedure - cable lead, earthing wire and cable bushing

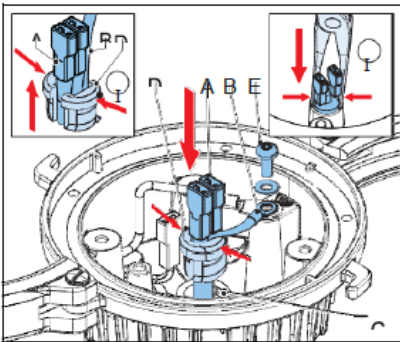

5.3.11 Part Replacement - Frangible Coupling or Column



Note

Refer to [Exploded View](#) section for more information on parts.

- Frangible coupling
- Column

Tools:

- Open spanner, size 11
- Alignment tool

Removing the frangible coupling

1. Loosen the nut (A).
2. Loosen the screw (B).
3. Loosen the alignment screws (C).
4. Remove the frangible coupling (D).
5. Remove the column (E).

Figure 37: Removal procedure - frangible coupling

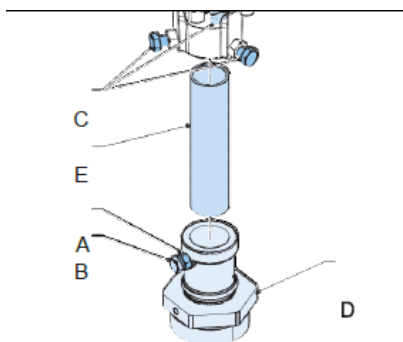

Installation

1. Install the new frangible coupling.
2. Install the column.



Note

Refer to [Screws Overview](#) (torque) section.

Tighten the screw (A) and the nut (B).



Note

Refer to [Screws Overview](#) (torque) section.

4. Install but do not tighten the alignment screws (C) and the nuts (D).

Figure 38: Installation procedure - frangible coupling

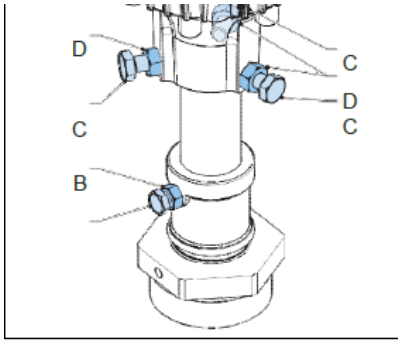

5.3.12 Repair a faulty Light (Monitoring Option)



Note

Refer to [Exploded View](#) section for more information on parts.

- Optical kit

Replacement procedure

1. Remove the complete optical head.



Note

Refer to [Part Replacement - complete optical Head](#) section.

2. Replace both optical kits.



Note

Refer to [Part Replacement - optical Kit](#) section.

3. Replace the fuse resistor.



Note

Refer to [Part Replacement - Fuse Resistor \(Monitoring Option\)](#) section.

4. Connect the LED MCPCBs.

Connection procedure

1. Perform a fixture operation test.



Note

Refer to [Fixture operation test](#) section.

2. If the fixture does not come on:

- a. Replace the complete optical head.



Note

Refer to [Part Replacement - complete optical Head](#) section.

- b. Perform an operation test.



Note

Refer to [Fixture operation test](#) section.

- c. If the fixture does not come on, contact ADB SAFEGATE.

Assembly procedure

1. Reinstall the complete optical head.



Note

Refer to [Part Replacement - complete optical Head](#) section.

5.3.13 Part Replacement - Fuse Resistor (Monitoring Option)



Note

Refer to [Exploded View](#) section for more information on parts.

- Fuse resistor kit

Tools:

- Pliers

Disassembly procedure

1. Remove the complete optical head.
-



Note

Refer to [Part Replacement - complete optical Head](#) section.

2. Pull the legs of the fuse resistor (A) and remove it from the sockets.
3. Dispose of the old fuse resistor.

Figure 39: Disassembly - fuse resistor

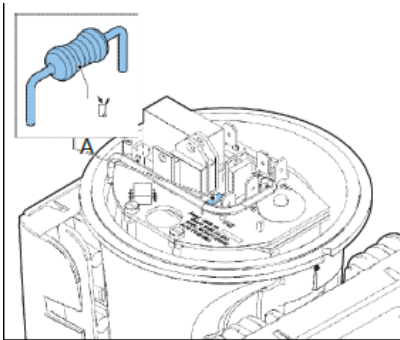

Assembly procedure

1. Insert the legs of the new fuse resistor in the sockets.
 2. Reinstall the complete optical head.
-



Note

Refer to [Part Replacement - complete optical Head](#) section.

5.3.14 Assembling the complete optical head



Note

Refer to [Exploded View](#) section for more information on parts.

- Body
- Optical kit
- LED MCPCB screws
- Optical cover
- Optical cover gasket
- Cooling block
- Cooling block washers
- Cooling block gasket
- Cooling block screws

Tools:

- Screwdriver, Torx T20 and T25

Installation

1. Install the cooling block on the body.



Note

Refer to [Part Replacement - Cooling Block](#) section.

2. Install the optical kit on the cooling block.



Note

Refer to [Part Replacement - optical Kit](#) section.

3. Install the optical cover.



Note

Refer to [Part Replacement - optical Cover](#) section.

5.3.15 Installing the Snow Rod Bracket (and Snow Rod)

Tools:

- 1 torx screwdriver TX 20
- 2 open end wrench 13 and 17

Installation

1. Loosen the alignment screws and nuts, remove the light from the pole and disconnect the cable.

2. Mount the snow rod bracket:

Figure 40: Required Material

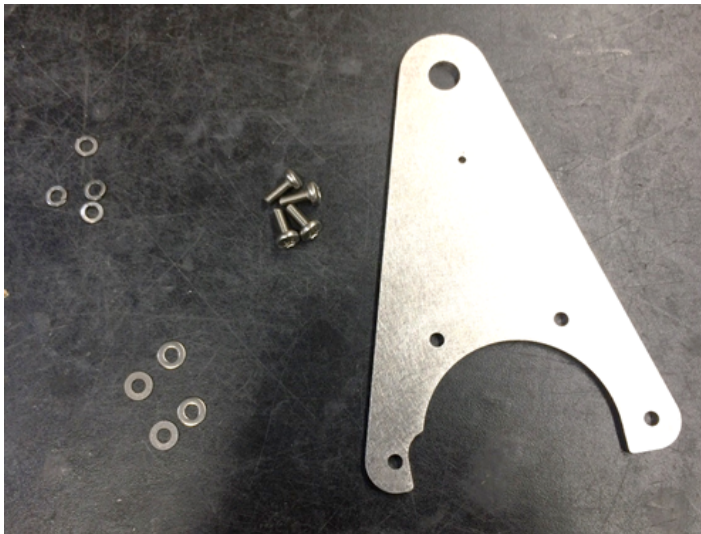
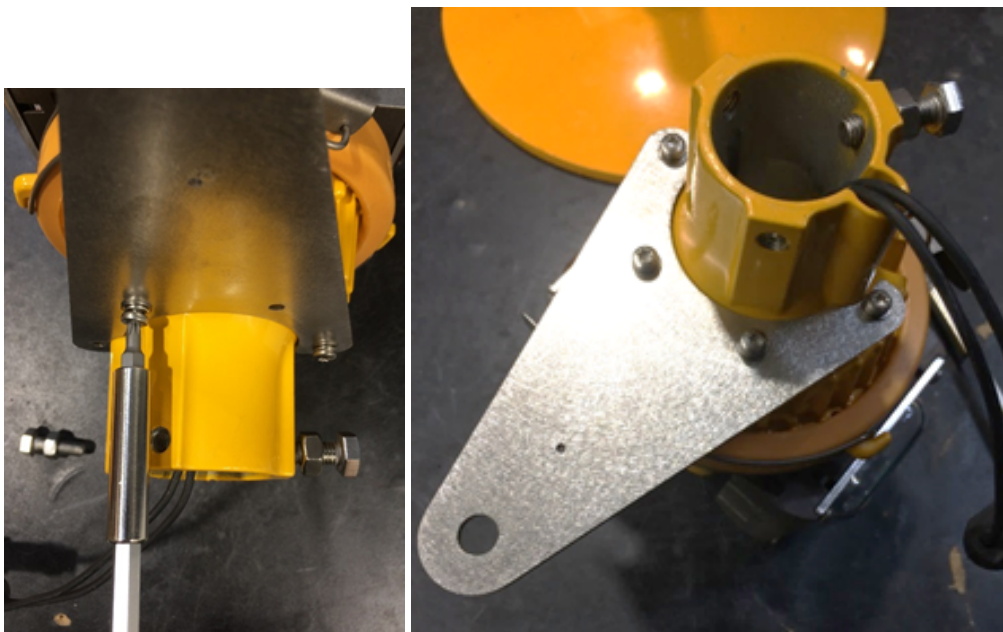

Figure 41: Mounting the Support Plate



- a. Use the support plate with 4x M4 screws, 4 washers and 4 lockwasher (refer to [Figure 40](#) figure).
- b. Mount the support plate with 4x M4 screws, washer and lockwasher to the body of the EREL.
- c. Tighten the M4 screws to 2.5 Nm.

3. Mount the snow rod.
 - a. Use the required material (refer to [Figure 42](#) figure).
 - b. Mount the snow rod to the support plate with the M10 nut and washer. Tighten the nut to 10 Nm.

Figure 42: Mounting the Snow Rod

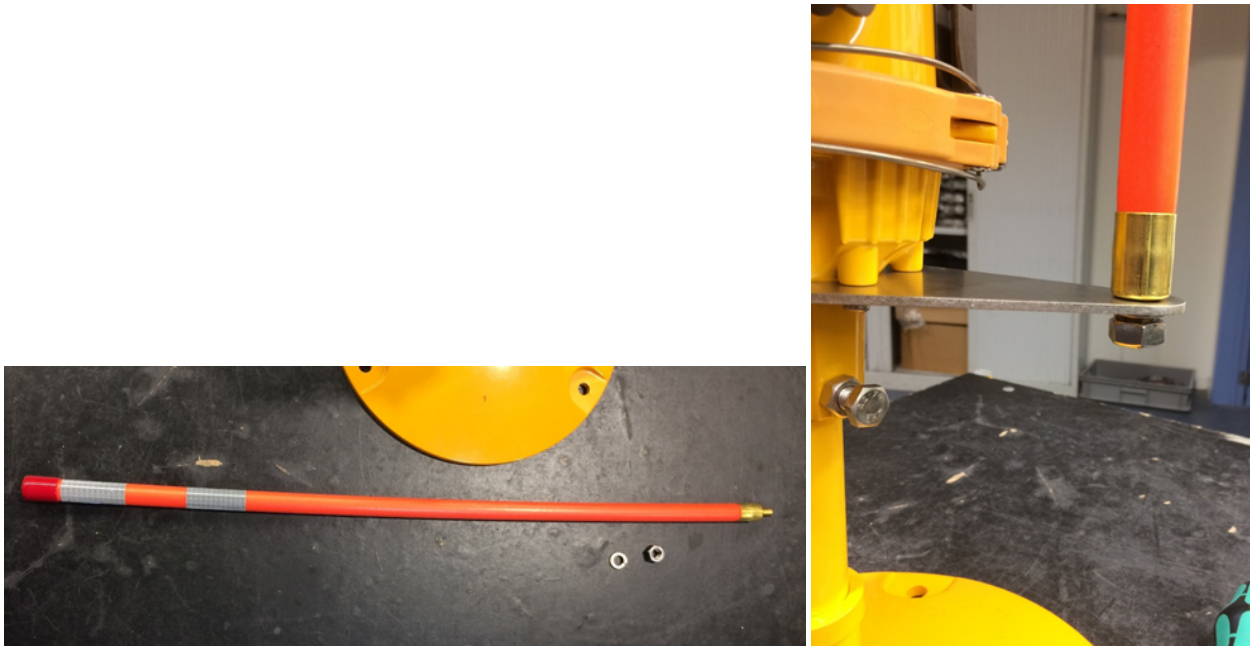

4. Mount the light back to the pole and re-align it.

5.4 Fixture operation test

Tools

- FAA or IEC series isolation transformer, powered from a FAA or IEC constant current regulator
1. Connect the fixture directly to the transformer. Do not use a remote communication unit between the fixture and the transformer.
 2. Set the step of the constant current generator to 6.6 A.
 3. Check if the light works properly for 10 s.
 4. Turn OFF the constant current generator.
 5. If the fixture did not work or has switched off before the end of the test time.



Note

Refer to the [Troubleshooting guide](#) section.

6.0 RELIANCE EREL and ERES Troubleshooting

6.1 Operation Safety



CAUTION

Improper Operation

Do Not Operate this equipment other than as specified by the manufacturer

- Only qualified personnel, physically capable of operating the equipment and with no impairments in their judgment or reaction times, should operate this equipment.
- Read all system component manuals before operating this equipment. A thorough understanding of system components and their operation will help you operate the system safely and efficiently.
- Before starting this equipment, check all safety interlocks, fire-detection systems, and protective devices such as panels and covers. Make sure all devices are fully functional. Do not operate the system if these devices are not working properly. Do not deactivate or bypass automatic safety interlocks or locked-out electrical disconnects or pneumatic valves.
- Protect equipment with safety devices as specified by applicable safety regulations.
- If safety devices must be removed for installation, install them immediately after the work is completed and check them for proper functioning.
- Route electrical wiring along a protected path. Make sure they will not be damaged by moving equipment.
- Never operate equipment with a known malfunction.
- Do not attempt to operate or service electrical equipment if standing water is present.
- Use this equipment only in the environments for which it is rated. Do not operate this equipment in humid, flammable, or explosive environments unless it has been rated for safe operation in these environments.
- Never touch exposed electrical connections on equipment while the power is ON.

Failure to follow these instructions can result in serious injury, death or equipment damage.

6.2 Troubleshooting guide

Table 1: Troubleshooting guide





Problem	Possible cause	Corrective action
Only one side of the fixture has light output	The LED MCPCB has a malfunction	Replace the optical kit.  Note Refer to the Part Replacement - optical Kit section.
Both sides of the fixture have no light or light flickers	The connection to the series circuit has a malfunction.	Examine the electrical connection, the cable and the receptacles. 1. Disconnect the plug from the secondary connection. 2. Test the series circuit with a spare fixture. 3. If the light is ok, replace the complete optical head. 4. If the light is not ok, adjust the input power. 5. Troubleshoot the series circuit.
	The input power has a malfunction.	

Table 1: Troubleshooting guide

Problem	Possible cause	Corrective action
	Connection of the body assembly to the LED module has a malfunction.	1. Remove the optical cover. 2. Check the electrical connection between the LED MCPCB and the body.  Note Refer to the Part Replacement - optical Cover section.
	The body assembly has a malfunction	Replace the body.  Note Refer to the Part replacement - arctic kit (arctic kit option) section.
Light output too low	The optical cover is dirty.	Clean the optical cover.
	The optical cover is defective.	Replace the optical cover.  Note Refer to the Part Replacement - optical Cover section.
	The LED MCPCB has a malfunction.	Replace the optical kit.  Note Refer to the Part Replacement - optical Kit section.

7.0 Spare Parts

7.1 Ordering Code EREL and ERES

Ordering Code

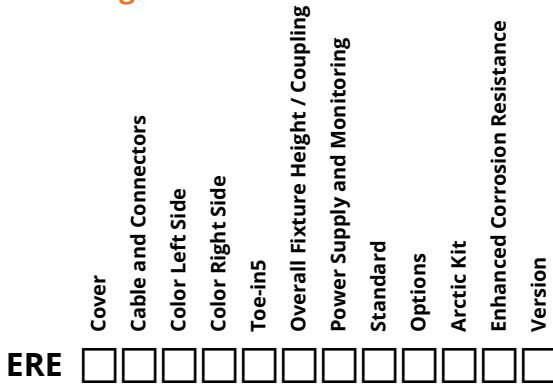

Cover

L = UV-resistant polycarbonate

S = Glass

Cable and Connectors

2 = 1 FAA L823 plug (2-pins)

6 = 1 plug (2-pins) w/Earth ground

8 = 1 external connected plug (2-pins)¹²

Color Left Side

W = White

R = Red

G = Green³⁴

Y = Yellow

N = None (Obscured)

Color Right Side

W = White

R = Red

G = Green³⁴

Y = Yellow

N = None (Obscured)

Toe-in⁵

0 = No toe-in⁴

1 = Left side with toe-in

2 = Right side with toe-in

3 = Both sides with toe-in

Overall Fixture Height / Coupling

1 = 14 in (35.6 cm) with 1.5" coupling, 12 TPI

2 = 20 in (50.8 cm) with 1.5" coupling, 12 TPI

3 = 24 in (61.0 cm) with 1.5" coupling, 12 TPI

5 = 14 in (35.6 cm) with 2" coupling, 11.5 TPI

6 = 20 in (50.8 cm) with 2" coupling, 11.5 TPI

7 = 24 in (61.0 cm) with 2" coupling, 11.5 TPI

9 = 14 in (35.6 cm) with 2" coupling, 11 TPI¹

Power Supply and Monitoring

S = 6.6A - 50/60 Hz series supply, without monitoring

M = 6.6A - 50/60 Hz series supply, with monitoring

P = IQ0 version⁶

Q = IQ1 version⁶

Standard

0 = ICAO- and FAA-compliant⁷

F = FAA (threshold only)

I = ICAO (threshold/end and threshold only)⁴

K = Australian (color to MOS 139)

Options

0 = No option

1 = With bracket for snow rod

Arctic Kit

0 = Without arctic kit

1 = With arctic kit⁸

Enhanced Corrosion Resistance

1 = Included

Version

2 = Improved mechanics

Ordering Code Notes

¹ Not defined by FAA, hence not ETL Certified.

² Cord set connected external to column.

³ G-green will only be delivered if Standard = K. All other applications will be delivered with F - green (ICAO / FAA).

⁴ ICAO / TP312 unidirectional threshold light is always without toe-in. These light fixtures have to be installed with a Toe-in to be compliant to the standards.

⁵ Refer to Toe-in Coding diagram for more information.

⁶ The IQ functionality allows control and monitoring of the fixture. IQ1 fixtures are preconfigured for the specific position at delivery. This function is disabled in IQ0 fixtures but could be enabled later.

⁷ All lights without green beam are compliant to ICAO and FAA. Use 0 for any application (FAA, ICAO, TP 312) that does not use green.

⁸ Not with IQ fixtures.



Note

Additionally please consider the following:

- Code for an ICAO unidirectional threshold light is ERE XX GN0 XX I XX12 , where X must be selected according to the table
- ICAO Stopway is always unidirectional, red and with toe-in
- White and yellow beams are for runway edge application and are always with toe-in
- Red beam may be with toe-in for runway edge application (e.g. displaced threshold) or without toe-in for runway end application
- Green beam is always with toe-in for FAA applications (See note 6 above for ICAO)

7.2 Exploded View

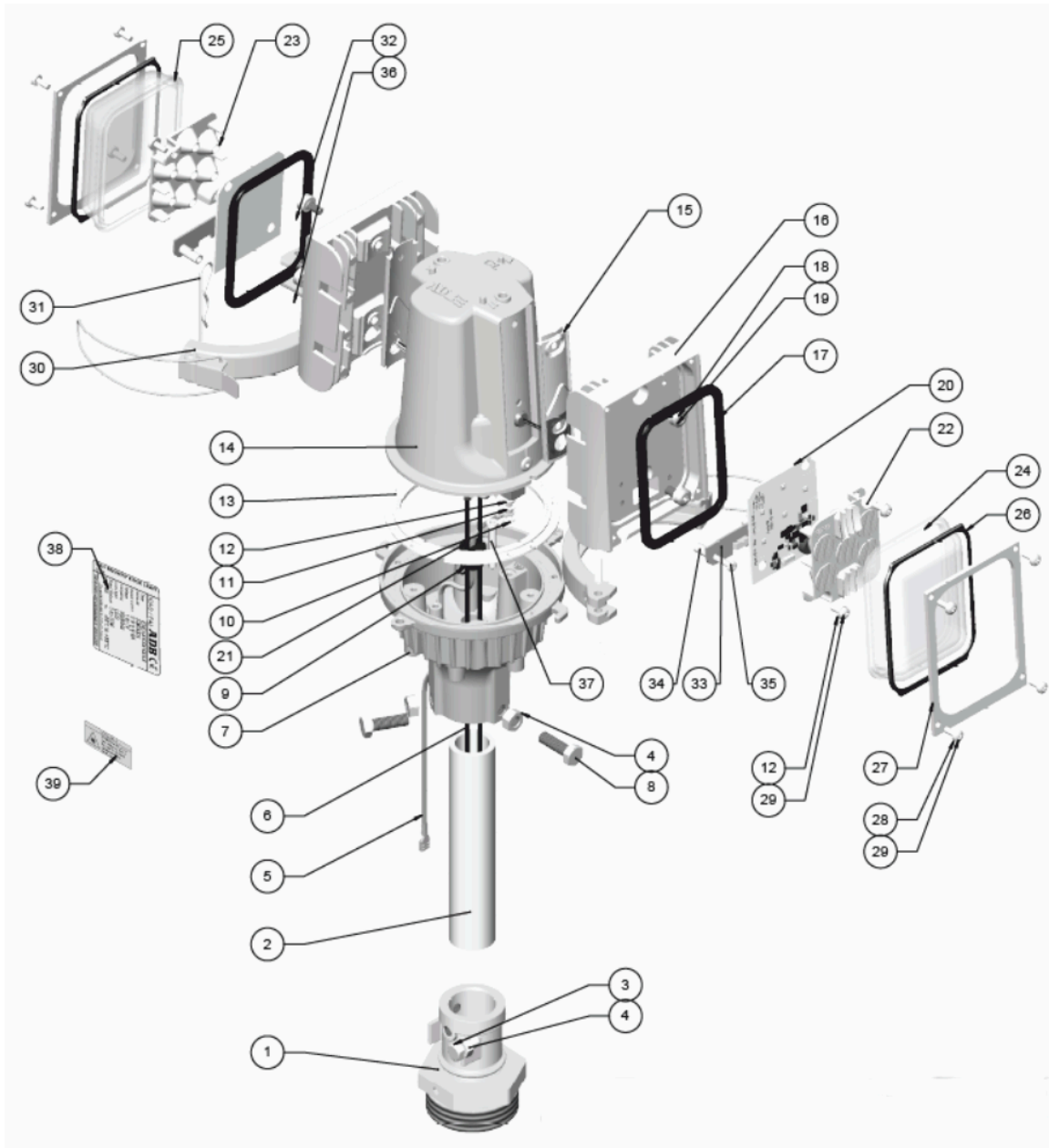

7.3 EREL and ERES Parts



NOTICE

For America spares, please refer to Americas product manual UM-3025 (US Version).

Exploded view reference numbers	Components	Versions	Part number
1, 3, 4	Frangible coupling (including screws and nuts)	2" 11 TPI thread less than 30" OAH	SP.4072.65.570
		2" 11.5 TPI thread less than 30" OAH	SP.4072.65.580
		1.5" 12 TPI thread less than 30" OAH	SP.4072.65.550
		2" 11 TPI thread 30" OAH	SP.4072.65.600
		2" 11.5 TPI thread 30" OAH	SP.4072.65.610
		1.5" 12 TPI thread 30" OAH	SP.4072.65.560
2	1" EMT column	for 350 mm OAH light (2" 11 TPI only)	SP.4072.60.340
		for 14" OAH light (not for 2" 11 TPI)	SP.012539
		for 20" OAH light (not for 2" 11 TPI)	SP.012540
		for 24" OAH light (not for 2" 11 TPI)	SP.012541
		for 30" OAH light (not for 2" 11 TPI)	SP.012615
	Optical kit	See the table 'Optical components' below	
3	M8 screw for frangible coupling (30 pcs)		SP.7100.08.647
4	M8 Nut for Alignment screw & Frangible Coupling (30 pcs)		SP.7150.53.260
4, 7, 8, 30, 31, 32, 36, 37	Body support assembly , complete with clips, safety pins and alignment screws		1406.00.666
5	Earthing cable	for 350 mm OAH light (2" 11 TPI only)	SP.011177
		for 14" OAH light (not for 2" 11 TPI)	SP.011178
		for 20" OAH light (not for 2" 11 TPI)	SP.011179
		for 24" OAH light (not for 2" 11 TPI)	SP.011180
		for 30" OAH light (not for 2" 11 TPI)	SP.013051
6	Cable lead	for 350 mm OAH light (2" 11 TPI only)	SP.010611
		for 14" OAH light (not for 2" 11 TPI)	SP.012516
		for 20" OAH light (not for 2" 11 TPI)	SP.012517
		for 24" OAH light (not for 2" 11 TPI)	SP.012518
		for 30" OAH light (not for 2" 11 TPI)	SP.012519
8	Alignment screw M8x25 A2 (30 pcs)		SP.7100.08.655
9	Cable strain relief bushing		SP.011243
11	Flat washer M4 Inox - DIN125 (25pcs)		SP.7283.04.230

Exploded view reference numbers	Components	Versions	Part number
13	Body gasket (25 pcs)		SP.4072.04.621
13, 14	Body with body gasket - no arctic kit	Without monitoring option	SP.010999
		With monitoring option	SP.012967
13, 14	Body with body gasket - with arctic kit	Without monitoring option	SP.012968
		With monitoring option	SP.012969
13, 14	Body IQ with body gasket	With IQ monitoring	SP.013052
15, 16, 18, 19	Cooling block kit (containing cooling block, cooling block gasket, cooling block screws and flat washer)	all versions except FAA L-862E green and except ICAO threshold/end green with toe-in left and right	SP.013053
		FAA L-862E green	SP.011003
		THR side of bidirectional ICAO THR/END fixture (right toe in)	SP.013054
		THR side of bidirectional ICAO THR/END fixture (left toe in)	SP.013055
	Cooling block gasket (10 pcs)		SP.010909
	Cooling block screws (20 pcs)		SP.7125.00.700
	Flat washer to cooling block (20 pcs)		SP.7283.04.470
	17	Optical cover gasket (10 pcs)	
17, 26, 27, 28, 29	Clip kit for optical cover (kit containing one clip, one spacer, screws, washers and one optical cover gasket) (5 pcs)		1406.00.670
20	Dummy LED board (for the blank side of unidirectional lights)		SP.1590.03.790
26	Optical clip spacer (10 pcs)		SP.4072.47.810
	Opticalcover	See the table 'Optical components' below	
28	Spring washer (40pcs)		SP.7284.10.416
29	Screw M4x10 A4+Loc2245 (40 pcs)		SP.7100.10.101
33, 34, 35	Arctic kit (kit containing one heater, two spacers and screws) (not for IQ)		1406.00.680
	Fuse resistor kit (20 resistors) For fixtures with monitoring option		6132.00.250

Table 2: Optical components

Exploded view references numbers	Applications	Color	Optical kit including the LED MCPCB and the optical block spacer, screws and washers	Optical cover (glass, 5 pcs) ref. No. 24 ¹	Optical cover (synthetic, 5 pcs) ref. No. 25 ¹
11, 20, 22, 29	ICAO runway end and FAA L-862E	Red	1406.00.640	SP.010902	SP.010907
	ICAO threshold	Green	1406.00.650	SP.010900	SP.010905
	MOS139 threshold	Green	1406.00.690	SP.010900	SP.010905
11, 20, 23, 29	ICAO runway edge and FAA L-862	White	1406.00.600	SP.010900	SP.010905
		Red	1406.00.610	SP.010902	SP.010907
		Yellow	1406.00.620	SP.010903	SP.010908
	FAA L-862 and FAA L862E	Green	1406.00.630	SP.010901	SP.010906



NOTICE

ICAO and MOS 139 threshold fixtures are equipped with a transparent optical cover. Use the code of the white lens even if this application emits green light.

7.4 Screws Overview

Name	Screw type	Quantity on a fixture	Torque (Nm)
Screw for the earthing cable	M4x10 A2-taptite	1	2.5
Alignment screw	M8x25 A2	3	8
Cooling block screw	M6x12	4 (2 on each side)	4.5
Optical block screw	M4x10 A2+loc2245	4 (2 on each side)	1.3
Screws of the optical cover clip	M4x10 A2+loc2245	8 (2 on each side)	2.5
Arctic kit screws	Plastic screw M4x25	4 (2 on each side)	0.3
Screw to connect the frangible coupling to the column	M8x20 DIN 933 (inox)	2	8

7.5 Options and Accessories



Note

The following parts can be ordered separately.

¹Except for ICAO and MOS139 threshold, all fixtures are equipped with a colored optical cover for daytime recognition.

	Details	Article number
A	Alignment tool	1408.35.130
B	Snow rod (10 pcs) (note: the light must be equipped with the optional bracket)	SP.4072.28.670
C	Snow rod bracket assembly (with screws & washers) (10 pcs)	SP.4072.28.570

Appendix A: POWER TABLE

EREL and ERES Fixture – Power Table

Fixture type	Fixture load	Isolation transformer			CCR load
		Rating	Loss	Efficiency	
without Arctic Kit:					
EREL (unidirectional)	29 VA	45 W	10 VA	0.85	39 VA
EREL (bidirectional)	33 VA	45 W	10 VA	0.85	43 VA
with Arctic Kit:					
ERES (unidirectional)	31 VA	45 W	10 VA	0.85	41 VA
ERES (bidirectional)	38 VA	45 W	10 VA	0.85	48 VA



NOTICE

IQ function (load): With IQ enabled an additional capacity of 12 W need to be added to the transformer calculations for the powerline communication of the ILCMS. This has to be available for the communication to pass through without saturating the transformer (this power is not used and should not be included in the CCR calculation).



CAUTION

RELIANCE IQ is not to be connected to transformers smaller than 65 W.



Note

- Extra losses in secondary cables or due to extra equipment (e.g. ILCMS remotes) are not included in above table; these extra losses will result in a higher required size of isolation transformers
- Extra losses in primary cables are not included in above table; these extra losses will result in a higher required CCR load
- Efficiency of the secondary transformer depends on the supplier of secondary transformers

For more information about the product, including manuals and certifications, please see our Product Center on the ADB SAFEGATE website: www.adbsafegate.com.

Appendix B: Cable Loss

The formula for measuring the cable resistance **R** (in ohms) for a single conductor is calculated with following formula:

$$R = \rho \times (L / A)$$

Where:

- **R** = resistance of the cable (in ohms, Ω)
- **ρ** = resistivity of the conductor material (in ohm-meters, $\Omega\cdot m$)
- **L** = length of the conductor (in meters, m)
- **A** = cross-sectional area of the conductor (in square meters, m^2)

Example: for 1 km of 2.5 mm² copper conductor (where the the resistivity (ρ) is 1.72 10⁻⁸ (m^2), the resistance R is calculated as follows:

$$(1.72 \cdot 10^{-8}) \times 1000 / (2.5 \cdot 10^{-6} m^2) = 6.88 \text{ ohms}$$

The loss (Watt) is then $R \times I^2$ or $6.88 \text{ ohms} \times 6.6^2 A^2 = 299.69 \text{ W/km}$ or 0.299 W/m .

The loss (Watt) for a secondary cable with 2 conductors is thus $2 \times 0.299 = 0.599$ or 0.6 W/m .

As such we can calculate:

- Secondary cable for a 2.5 mm² Cu-wire (2 conductors): 0.6 W/m
- Secondary cable for a 4 mm² Cu-wire (2 conductors): 0.4 W/m
- Primary cable for a 6 mm² Cu-wire (1 conductor): 0.12 W/m

The cable between the isolation transformer and the lamp adds losses that cannot be ignored when dimensioning the circuits and selecting rating for secondary transformers and regulators.



WARNING

Cable lengths should not exceed 100 meters.

For a secondary cable of e.g., 20 m of 2.5 mm² CU-wire, $20 \text{ m} \times 0.6 \text{ W/m} = 12 \text{ W}$ equals the additional loss to be taken into account.

For a primary cable of e.g., 100 m of 6 mm² CU-wire, $100 \text{ m} \times 0.12 \text{ W/m} = 12 \text{ W}$ equals the additional loss to be taken into account.

Appendix C: Support

Our experienced engineers are available for support and service at all times, 24 hour/7 days a week. They are part of a dynamic organization making sure the entire ADB SAFEGATE is committed to minimal disturbance for airport operations.

ADB SAFEGATE Support

Technical Support – Global

Customers in Europe, the Middle East, Africa and Asia Pacific are more than welcome to our portal for technical support. Trained in all areas of system issues, troubleshooting, quality control and technical assistance, our highly experienced Technical support specialists are available 24 hours a day, seven days a week to provide assistance over the phone.

Europe: **+32-2-722-17-11**

China: **+86-10-8476-0106**

Middle East and Africa: **+971-4-452-7575**

In the Americas, we also offer live technical support.

Live Technical Support – Americas

If at any time you have a question or concern about your product, contact ADB SAFEGATE's US-based technical support specialists, available 24 hours a day, seven days a week, to assist you via phone.

ADB SAFEGATE Americas Technical Service & Support (US & Canada) :**+1-800-545-4157**

ADB SAFEGATE Americas Technical Service & Support (Canada): **+1-905-631-1597**

ADB SAFEGATE Americas Technical Service & Support (International): **+1-614-861-1304**. For technical service press 3 and for sales support press 4.

We can also be reached via email during regular business hours.

Airfield and Gate: **techservice.us@adbsafegate.com**

Gate: **gateservice.us@adbsafegate.com**

We look forward to working with you!

Before You Call

When you have an airfield lighting or control system problem, prior to calling, please ensure the following:

- Review the product's manual and troubleshooting guide.
- Be located with the product ready to troubleshoot.
- Have all necessary information available: airport code/company name, customer id number, contact phone number/email address, product/part number.
- Have all necessary tools that may be needed at hand.

When calling about an issue with Safedock A-VDGS, we can serve you better if you collect the following information before you call:

- Relevant information regarding the issue you are calling about, such as gate number, flight number, aircraft type and time of the event.
- What, if any, actions have been taken to resolve the issue prior to the call.
- If available, provide a CCTV recording of the incident to aid in aligning the information from the Safedock log file.

For more information, see www.adbsafegate.com, contact ADB SAFEGATE Support via email at **support@adbsafegate.com**.

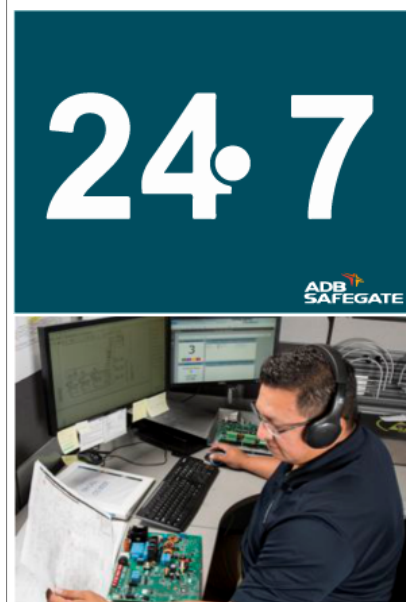

C.1 ADB SAFEGATE Website

The ADB SAFEGATE website, www.adbsafegate.com, offers information regarding our airport solutions, products, company, news, links, downloads, references, contacts and more.

C.2 Recycling

C.2.1 Local Authority Recycling

The disposal of ADB SAFEGATE products is to be made at an applicable collection point for the recycling of electrical and electronic equipment. The correct disposal of equipment prevents any potential negative consequences for the environment and human health, which could otherwise be caused by inappropriate waste handling. The recycling of materials helps to conserve natural resources. For more detailed information about recycling of products, contact your local authority city office.

C.2.2 ADB SAFEGATE Recycling

ADB SAFEGATE is fully committed to environmentally-conscious manufacturing with strict monitoring of our own processes as well as supplier components and sub-contractor operations. ADB SAFEGATE offers a recycling program for our products to all customers worldwide, whether or not the products were sold within the European Union (EU).

ADB SAFEGATE products and/or specific electrical and electronic component parts which are fully removed/separated from any customer equipment and returned will be accepted for our recycling program.

All items returned must be clearly labeled as follows:

- For Restriction of Hazardous Substances (*RoHS*)/Waste Electrical and Electronic Equipment (*WEEE*) Recycling
- Sender contact information (Name, Business Address, Phone number).
- Main Unit Serial Number.

ADB SAFEGATE will continue to monitor and update according for any future requirements for *EU directives* as and when *EU member states* implement new *regulations* and or *amendments*. It is our aim to maintain our *compliance plan* and assist our customers.

Company Addresses

ADB SAFEGATE, Belgium	ADB SAFEGATE BV Leuvensesteenweg 585 B-1930 Zaventem Belgium
Contact:	
Tel.: +32 2 722 17 11	Email: marketing@adbsafegate.com
Fax: +32 2 722 17 64	Internet: www.adbsafegate.com
ADB SAFEGATE, Americas	ADB SAFEGATE Americas, LLC 700 Science Blvd Gahanna, OH 43230 USA
Contact:	
Tel.: +1 (614) 861 1304	Email: sales.us@adbsafegate.com
Fax: +1 (614) 864 2069	Internet: www.adbsafegate.com
ADB SAFEGATE, Sweden	ADB SAFEGATE Sweden AB Djurhagegatan 19 SE-213 76 Malmö Sweden
Contact:	
Tel.: +46 (0)40 699 17 00	Email: marketing@adbsafegate.com
Fax: +46 (0)40 699 17 30	Internet: www.adbsafegate.com
ADB SAFEGATE, China	ADB SAFEGATE Airfield Technologies Ltd. China Unit 603, D Block, CAMIC International Convention Center, No 3, Hua Jia Di East road, ChaoYang district, Beijing 100102 P.R. China
Contact:	
Tel.: +86 (10) 8476 0106	Email: china@safegate.com
Fax: +86 (10) 8476 0090	Internet: www.adbsafegate.com
ADB SAFEGATE, Germany	ADB SAFEGATE Germany GmbH Konrad-Zuse-Ring 6, D-68163 Mannheim Germany
Contact:	
Tel.: +49 (621) 87 55 76-0	Email: marketing@adbsafegate.com
Fax: +49 (621) 87 55 76-55	Internet: www.adbsafegate.com

WWW.ADBSAFEGATE.COM

Empowering the Airside Evolution

SMARTER. BETTER. NOW.

