



AXON Omni Protected Dome Inset Lights
8-inch and 12-inch Taxiway Edge (TE), Apron Aircraft Maneuvering (AM)

User Manual

UM-5091, Rev. 1.4, 2023/01/06



A.0 Disclaimer / Standard Warranty

CE certification

The equipment listed as CE certified means that the product complies with the essential requirements concerning safety and hygiene. The European directives that have been taken into consideration in the design are available on written request to ADB SAFEGATE.

ETL certification

The equipment listed as ETL certified means that the product complies with the essential requirements concerning safety and FAA Airfield regulations. The FAA directives that have been taken into consideration in the design are available on written request to ADB SAFEGATE.

All Products Guarantee

ADB SAFEGATE will correct by repair or replacement per the applicable guarantee above, at its option, equipment or parts which fail because of mechanical, electrical or physical defects, provided that the goods have been properly handled and stored prior to installation, properly installed and properly operated after installation, and provided further that Buyer gives ADB SAFEGATE written notice of such defects after delivery of the goods to Buyer. Refer to the Safety section for more information on Material Handling Precautions and Storage precautions that must be followed.

ADB SAFEGATE reserves the right to examine goods upon which a claim is made. Said goods must be presented in the same condition as when the defect therein was discovered. ADB SAFEGATE further reserves the right to require the return of such goods to establish any claim.

ADB SAFEGATE's obligation under this guarantee is limited to making repair or replacement within a reasonable time after receipt of such written notice and does not include any other costs such as the cost of removal of defective part, installation of repaired product, labor or consequential damages of any kind, the exclusive remedy being to require such new parts to be furnished.

ADB SAFEGATE's liability under no circumstances will exceed the contract price of goods claimed to be defective. Any returns under this guarantee are to be on a transportation charges prepaid basis. For products not manufactured by, but sold by ADB SAFEGATE, warranty is limited to that extended by the original manufacturer. This is ADB SAFEGATE's sole guarantee and warranty with respect to the goods; there are no express warranties or warranties of fitness for any particular purpose or any implied warranties of fitness for any particular purpose or any implied warranties other than those made expressly herein. All such warranties being expressly disclaimed.

Standard Products Guarantee

Products manufactured by ADB SAFEGATE are guaranteed against mechanical, electrical, and physical defects (excluding lamps) which may occur during proper and normal use for a period of two years from the date of ex-works delivery, and are guaranteed to be merchantable and fit for the ordinary purposes for which such products are made.



Note

See your applicable sales agreement for a complete warranty description.

Replaced or repaired equipment under warranty falls into the warranty of the original delivery. No new warranty period is started for these replaced or repaired products.

FAA Certified products manufactured by ADB SAFEGATE

ADB SAFEGATE L858 Airfield Guidance Signs are warranted against mechanical and physical defects in design or manufacture for a period of 2 years from date of installation, per FAA AC 150/5345-44 (applicable edition).

ADB SAFEGATE LED products (with the exception of obstruction lighting) are warranted against electrical defects in design or manufacture of the LED or LED specific circuitry for a period of 4 years from date of installation, per FAA EB67 (applicable edition). These FAA certified constant current (series) powered LED products must be installed, interfaced and powered with and through products certified under the FAA Airfield Lighting Equipment Program (ALECP) to be included in this 4 (four) year warranty. This includes, but is not limited to, interface with products such as Base Cans, Isolation Transformers, Connectors, Wiring, and Constant Current Regulators.



Note

See your sales order contract for a complete warranty description.

Replaced or repaired equipment under warranty falls into the warranty of the original delivery. No new warranty period is started for these replaced or repaired products.

Liability



WARNING

Use of the equipment in ways other than described in the catalog leaflet and the manual may result in personal injury, death, or property and equipment damage. Use this equipment only as described in the manual.

ADB SAFEGATE cannot be held responsible for injuries or damages resulting from non-standard, unintended uses of its equipment. The equipment is designed and intended only for the purpose described in the manual. Uses not described in the manual are considered unintended uses and may result in serious personal injury, death or property damage.

Unintended uses, includes the following actions:

- Making changes to equipment that have not been recommended or described in this manual or using parts that are not genuine ADB SAFEGATE replacement parts or accessories.
- Failing to make sure that auxiliary equipment complies with approval agency requirements, local codes, and all applicable safety standards if not in contradiction with the general rules.
- Using materials or auxiliary equipment that are inappropriate or incompatible with your ADB SAFEGATE equipment.
- Allowing unskilled personnel to perform any task on or with the equipment.

© ADB SAFEGATE SWEDEN AB

This manual or parts thereof may not be reproduced, stored in a retrieval system, or transmitted, in any form or by any means, electronic, mechanical, photocopying, recording, nor otherwise, without ADB SAFEGATE SWEDEN AB's prior written consent.

This manual could contain technical inaccuracies or typographical errors. ADB SAFEGATE SWEDEN AB reserves the right to revise this manual from time to time in the contents thereof without obligation of ADB SAFEGATE SWEDEN AB to notify any person of such revision or change. Details and values given in this manual are average values and have been compiled with care. They are not binding, however, and ADB SAFEGATE SWEDEN AB disclaims any liability for damages or detriments suffered as a result of reliance on the information given herein or the use of products, processes or equipment to which this manual refers. No warranty is made that the use of the information or of the products, processes or equipment to which this manual refers will not infringe any third party's patents or rights. The information given does not release the buyer from making their own experiments and tests.

© ADB SAFEGATE BV

This manual or parts thereof may not be reproduced, stored in a retrieval system, or transmitted, in any form or by any means, electronic, mechanical, photocopying, recording, nor otherwise, without ADB SAFEGATE BV's prior written consent.

This manual could contain technical inaccuracies or typographical errors. ADB SAFEGATE BV reserves the right to revise this manual from time to time in the contents thereof without obligation of ADB SAFEGATE BV to notify any person of such revision or change. Details and values given in this manual are average values and have been compiled with care. They are not binding, however, and ADB SAFEGATE BV disclaims any liability for damages or detriments suffered as a result of reliance on the information given herein or the use of products, processes or equipment to which this manual refers. No warranty is made that the use of the information or of the products, processes or equipment to which this manual refers will not infringe any third party's patents or rights. The information given does not release the buyer from making their own experiments and tests.

TABLE OF CONTENTS

1.0 Safety	1
1.1 Safety Messages	1
1.1.1 Introduction to Safety	2
1.1.2 Intended Use	2
1.1.3 Material Handling Precautions: Storage	3
1.1.4 Operation Safety	3
1.1.5 Maintenance Safety	3
1.1.6 Material Handling Precautions: Fasteners	4
1.1.7 Material Handling Precautions, ESD	4
2.0 About this Manual	5
2.1 How to work with the Manual	5
2.2 Abbreviations and Terms	5
3.0 Introduction	7
3.1 Product Information	7
3.2 Dimensions and Weight	10
4.0 Installation	11
4.1 Tools required	11
4.2 Installation Overview	11
4.3 Safety Considerations	13
4.4 Photobiological safety	13
4.5 Verify Input Requirements and Equipment Needed	13
4.6 Unpacking the Unit	14
4.7 Inspect on delivery	14
5.0 Maintenance	15
5.1 Basic Maintenance Program	15
5.2 Recommended Maintenance Program for optimal Service Life	16
5.2.1 Recommendation	17
5.3 Workshop Maintenance	19
5.3.1 Exploded View	20
5.3.2 Open and close a 12-inch Fixture	21
5.3.3 Closing an 12-inch Light Fixture	23
5.3.4 Opening an 8-inch Fixture	25
5.3.5 Closing an 8-inch Light Fixture	26
5.3.6 Checking the Light Fixture for Water-tightness	27
5.3.7 Replace a Light Engine in a 12-inch and an 8-inch Fixture	30
5.3.8 Replacing the Top Cover of a 12-inch Fixture	32
5.3.9 Replacing the Top Cover of an 8-inch Fixture	33
5.3.10 Replacing the Connection Board of an 8-inch fixture	34
5.3.11 Replacing the Connection Board of a 12-inch fixture	37
5.3.12 Replacing the LED Board	39
5.3.13 Replace a Prism and its Gasket in a 12-inch Fixture	40
5.3.14 Replacing a prism, its gaskets and the blue spacers (prism protection plates) in a 8-inch fixture	43
5.3.15 Replace the Bottom Cover and Converter of a 12-inch Fixture	46
5.3.16 Replace the Bottom Cover and Converter of a 8-inch Fixture	46
5.3.17 Reset the Fail-Open Converter	47
6.0 Ordering codes	49
6.1 Ordering Code L-852T(L) LED Taxiway Edge	49
6.2 Ordering Code Apron Maneuvering	51
7.0 Spare Parts	53
7.1 Exploded View	54
7.2 Spare Parts - Taxiway Edge	57

8.0 CABLE LOSS	61
9.0 INTEROPERABILITY	63
10.0 POWER TABLE	65
11.0 SUPPORT	67
11.1 ADB SAFEGATE Website	67
11.2 Recycling	67
11.2.1 Local Authority Recycling	67
11.2.2 ADB SAFEGATE Recycling	68

List of Figures

Figure 1: Installation on 8" shallow base	11
Figure 2: Diagram of the Fixture Installed in a 1-Piece Base Can	12
Figure 3: Anti-vibration washer example	12
Figure 4: Omnidirectional Light, 4 prisms, 8-inch	20
Figure 5: Fixture upside down	21
Figure 6: Lift up housing	21
Figure 7: Remove gasket	21
Figure 8: Converter with 1 connector	22
Figure 9: Fixture facing down	22
Figure 10: Tighten screws	22
Figure 11: Converter with 1 connector	23
Figure 12: Fixture facing down	24
Figure 13: Tightening screws	24
Figure 14: Fixture upside down	25
Figure 15: Lifting up housing	25
Figure 16: Removing gasket	25
Figure 17: Converter	26
Figure 18: Fixture facing down	27
Figure 19: Tightening screws	27
Figure 20: Pressure-relief screw removal	28
Figure 21: Light engine	30
Figure 22: Tighten screws	31
Figure 23: Top cover with bottom cover	32
Figure 24: Top cover with bottom cover	33
Figure 25: Replacing the connection board	34
Figure 26: Two connector types (replaceable)	36
Figure 27: Red and black cable connections	36
Figure 28: Replacing the connection board	37
Figure 29: Two connector types (replaceable)	39
Figure 30: Red and black cable connections	39
Figure 31: LED sub assembly (Optical assembly)	40
Figure 32: Remove LED board holder	41
Figure 33: Remove prism and gasket	41
Figure 34: Exploded View	41
Figure 35: New prism into prism gasket	42
Figure 36: Prism holder edge	42

Figure 37: Tighten screws in sequence	42
Figure 38: Exploded view - prism replacement	43
Figure 39: Remove LED board holder	44
Figure 40: Remove prism and gasket	44
Figure 41: New prism into prism gasket	44
Figure 42: Prism holder edge	45
Figure 43: Tighten screws in sequence	45
Figure 44: Correct gasket position	45
Figure 45: Gasket	46
Figure 46: Converter with 1 connector	46
Figure 47: Converter with 1 connector	47
Figure 48: Converter	47
Figure 49: Omnidirectional Light, 4 prisms, 12-inch	54
Figure 50: Omnidirectional Light, 4 prisms, 8-inch	55

List of Tables

Table 1: Suggested Tools and Materials for Installation and Repair	13
Table 2: Legend Exploded View	20
Table 3: Exploded View Legend — Top Cover Assembly, 12 inch	41
Table 4: Legend Exploded View	54
Table 5: Legend Exploded View	55
Table 6: Interoperability matrix	63

1.0 Safety

Introduction to Safety







This section contains general safety instructions for installing and using ADB SAFEGATE equipment. Some safety instructions may not apply to the equipment in this manual. Task- and equipment-specific warnings are included in other sections of this manual where appropriate.

1.1 Safety Messages

HAZARD Icons used in the manual

For all HAZARD symbols in use, see the Safety section. All symbols must comply with ISO and ANSI standards.

Carefully read and observe all safety instructions in this manual, which alert you to safety hazards and conditions that may result in personal injury, death or property and equipment damage and are accompanied by the symbol shown below.

	<p>WARNING</p> <p>Failure to observe a warning may result in personal injury, death or equipment damage.</p>
	<p>DANGER - Risk of electrical shock or ARC FLASH</p> <p>Disconnect equipment from line voltage. Failure to observe this warning may result in personal injury, death, or equipment damage. ARC Flash may cause blindness, severe burns or death.</p>
	<p>WARNING - Wear personal protective equipment</p> <p>Failure to observe may result in serious injury.</p>
	<p>WARNING - Do not touch</p> <p>Failure to observe this warning may result in personal injury, death, or equipment damage.</p>
	<p>CAUTION</p> <p>Failure to observe a caution may result in equipment damage.</p>
	<p>ELECTROSTATIC SENSITIVE DEVICES</p> <p>This equipment may contain electrostatic devices.</p>

Qualified Personnel

	<p>Important Information</p> <p>The term qualified personnel is defined here as individuals who thoroughly understand the equipment and its safe operation, maintenance and repair. Qualified personnel are physically capable of performing the required tasks, familiar with all relevant safety rules and regulations and have been trained to safely install, operate, maintain and repair the equipment. It is the responsibility of the company operating this equipment to ensure that its personnel meet these requirements.</p> <p>Always use required personal protective equipment (PPE) and follow safe electrical work practice.</p>
---	--

1.1.1 Introduction to Safety



CAUTION

Unsafe Equipment Use

This equipment may contain electrostatic devices, hazardous voltages and sharp edges on components

- Read installation instructions in their entirety before starting installation.
- Become familiar with the general safety instructions in this section of the manual before installing, operating, maintaining or repairing this equipment.
- Read and carefully follow the instructions throughout this manual for performing specific tasks and working with specific equipment.
- Make this manual available to personnel installing, operating, maintaining or repairing this equipment.
- Follow all applicable safety procedures required by your company, industry standards and government or other regulatory agencies.
- Install all electrical connections to local code.
- Use only electrical wire of sufficient gauge and insulation to handle the rated current demand. All wiring must meet local codes.
- Route electrical wiring along a protected path. Make sure they will not be damaged by moving equipment.
- Protect components from damage, wear, and harsh environment conditions.
- Allow ample room for maintenance, panel accessibility, and cover removal.
- Protect equipment with safety devices as specified by applicable safety regulations
- If safety devices must be removed for installation, install them immediately after the work is completed and check them for proper functioning prior to returning power to the circuit.

Failure to follow this instruction can result in serious injury or equipment damage

Additional Reference Materials



Important Information

- IEC - International Standards and Conformity Assessment for all electrical, electronic and related technologies.
- IEC 60364 - Electrical Installations in Buildings.
- FAA Advisory: AC 150/5340-26 (current edition), Maintenance of Airport Visual Aid Facilities.
- Maintenance personnel must refer to the maintenance procedure described in the ICAO Airport Services Manual, Part 9.
- ANSI/NFPA 79, Electrical Standards for Metalworking Machine Tools.
- National and local electrical codes and standards.

1.1.2 Intended Use



CAUTION

Use this equipment as intended by the manufacturer

This equipment is designed to perform a specific function, do not use this equipment for other purposes

- Using this equipment in ways other than described in this manual may result in personal injury, death or property and equipment damage. Use this equipment only as described in this manual.

Failure to follow this instruction can result in serious injury or equipment damage

1.1.3 Material Handling Precautions: Storage



CAUTION

Improper Storage

Store this equipment properly

- If equipment is to be stored prior to installation, it must be protected from the weather and kept free of condensation and dust.

Failure to follow this instruction can result in equipment damage

1.1.4 Operation Safety



CAUTION

Improper Operation

Do Not Operate this equipment other than as specified by the manufacturer

- Only qualified personnel, physically capable of operating the equipment and with no impairments in their judgment or reaction times, should operate this equipment.
- Read all system component manuals before operating this equipment. A thorough understanding of system components and their operation will help you operate the system safely and efficiently.
- Before starting this equipment, check all safety interlocks, fire-detection systems, and protective devices such as panels and covers. Make sure all devices are fully functional. Do not operate the system if these devices are not working properly. Do not deactivate or bypass automatic safety interlocks or locked-out electrical disconnects or pneumatic valves.
- Protect equipment with safety devices as specified by applicable safety regulations.
- If safety devices must be removed for installation, install them immediately after the work is completed and check them for proper functioning.
- Route electrical wiring along a protected path. Make sure they will not be damaged by moving equipment.
- Never operate equipment with a known malfunction.
- Do not attempt to operate or service electrical equipment if standing water is present.
- Use this equipment only in the environments for which it is rated. Do not operate this equipment in humid, flammable, or explosive environments unless it has been rated for safe operation in these environments.
- Never touch exposed electrical connections on equipment while the power is ON.

Failure to follow these instructions can result in equipment damage

1.1.5 Maintenance Safety



DANGER

Electric Shock Hazard

This equipment may contain electrostatic devices

- Do not operate a system that contains malfunctioning components. If a component malfunctions, turn the system OFF immediately.
- Disconnect and lock out electrical power.
- Allow only qualified personnel to make repairs. Repair or replace the malfunctioning component according to instructions provided in its manual.

Failure to follow these instructions can result in death or equipment damage

1.1.6 Material Handling Precautions: Fasteners



DANGER

Foreign Object Damage - FOD

This equipment may contain fasteners that may come loose - torque properly.

- Only use fasteners of the same type as the one originally supplied with the equipment.
- Use of incorrect combination of gaskets, bolts and nuts can create severe damages to the product installation and create safety risk .
- You need to know what base the light fixture will be installed in, in order to chose the correct gasket, bolts and nuts.
- Bolt type, length, and torque value are determined by type of base, height of spacers used, and clamp force required in FAA Engineering Brief No 83 (latest revision).
- Due to the risk of bolts vibrating loose, do not use any type of washer with the fixing bolts (such as split lock washers) other than an anti-vibration washer. Anti-vibration washers as defined in FAA EB 83 (latest edition) must be used. For installations other than FAA, use the base can manufacturer's recommendations.
- Always tighten the fasteners to the recommended torque. Use a calibrated torque wrench and apply the recommended adhesive type.
- Obey the instructions of the adhesives necessary for the fasteners.

Failure to follow these warnings may cause the fasteners to loosen, damage the equipment, potentially to loosen the equipment. This can lead to a highly dangerous situation of FOD, with potential lethal consequences.



Note

To minimize the risk of errors, the ADB SAFEGATE Sales Representative will have information on which gasket goes with which base. This information is also provided in the product Data sheets, the User Manuals and the Spare Part Lists.



CAUTION

Use of incorrect combination of gaskets, bolts and nuts can create severe damages to the product installation and create multiple safety risks.

To obtain a safe and watertight installation the O-ring and retaining bolt stated in the document must be used.

You need to know what base the light fixture will be installed in, in order to choose the correct gasket, bolts and nuts.

Failure to follow these cautions can result in equipment damage or aircraft FOD.

1.1.7 Material Handling Precautions, ESD



CAUTION

Electrostatic Sensitive Devices

This equipment may contain electrostatic devices

- Protect from electrostatic discharge.
- Electronic modules and components should be touched only when this is unavoidable e.g. soldering, replacement.
- Before touching any component of the cabinet you shall bring your body to the same potential as the cabinet by touching a conductive earthed part of the cabinet.
- Electronic modules or components must not be brought in contact with highly insulating materials such as plastic sheets, synthetic fiber clothing. They must be laid down on conductive surfaces.
- The tip of the soldering iron must be grounded.
- Electronic modules and components must be stored and transported in conductive packing.

Failure to follow this instruction can result in equipment damage

2.0 About this Manual

This document includes AXON runway inset light fixture information with a focus on safety, installation and maintenance procedures.

For more information, see www.adbsafegate.com.



Note

It is very important to read this document before any work is started.

This manual covers the following 8- and 12-inch fixtures:

- Taxiway Edge, L-852T(L)
- Apron Maneuvering

2.1 How to work with the Manual

- Familiarize yourself with the structure and content.
- Carry out the actions completely and in the given sequence.

2.2 Abbreviations and Terms

This document may include abbreviations and terms.

Abbreviation and term	Description
CAA	Civil Aviation Authority
CCR	Constant Current Regulator
FAA	Federal Aviation Administration
ICAO	International Civil Aviation Organization
IEC	International Electrotechnical Committee
ILCMS	Individual Light Control and Monitoring System
LED	Light Emitting Diode
NATO	North Atlantic Treaty Organization
STAC	Service Technique de l'Aviation Civile (France)
STANAG	Standardization Agreement (NATO)

3.0 Introduction

AXON — The all in one revolution

The 12-inch and 8-inch ranges are bi-, uni- or omnidirectional low protrusion light-emitting diode (LED) inset light fixtures, available in multiple versions:

Non-MON	Basic operation providing power only
MON (Fail-open)	A LED light fixture with integrated fail open technology with CCR monitoring compatibility
EQ	Fixture with integrated ILCMS remote utilizing orthogonal frequency-division multiplexing (OFDM) technology providing superior communication interfacing with LINC 360 System.



NOTICE

All our light fixtures are equipped with failed LED detection monitoring as required by FAA Engineering Brief 67.



Note

EQ light fixtures are not fail-open light fixtures. The monitoring as well as the control functionality is handled by the ILCMS system.

3.1 Product Information

Compliance and Standards

Compliance	Description	Application:	TE	AM
		Reference DS-XXXX:	5024	4002
FAA	AC 150/5345-46 and the FAA Engineering Brief No. 67		X	
ICAO	Annex 14 Volume 1		X	X
EASA	CS-ADR-DSN		X	X
Australia	MOS 139		X	X
Canada	TP 312		X	X
IEC	61827		X	X
NATO	STANAG 3316		X	
STAC	PRO/STAC/SE/VIS			
UK	CAP 168			
US Navy	NAVAIR 5150AAA-2, WP 006-04		X	
UFC	3-535-01		X	
CE			X	X

Application TE

FAA

- L-852T(L) Taxiway Edge

ICAO

- Taxiway Edge

NAVAIR

- Taxiway Edge
- Termination Centerline

UFC

- Taxiway Edge
- Taxiway End

TP-312

- Taxiway Edge
- Apron Exit Light

Application AM

ICAO

- Aircraft Stand Maneuvering Guidance

Features and Benefits

Efficiency

- EQ has an integrated ILCMS remote for use with the LINC 360 system providing high data capacity and resisting degradation from various types of radio effects to provide a superior communication platform
- Precision aimed optics enhancing photometric performance and complementing extended LED life
- Reduced bottom pan profile allowing for very shallow base can installation
- LEDs pulse width modulated (PWM) at 400 Hz optimizing LED performance and eliminating perceptible flicker to a moving human observer throughout the range of brightness steps
- Operates at all steps of constant current regulator technologies designed in compliance with IEC or FAA requirements
- Fully dimmable lights, conforming to the dimming curve of traditional halogen lights
- Low protrusion, high-intensity, Style 3 (≤ 6.35 mm) inset light fixtures
- No negative slope in front of the prisms

Sustainability

- Fully encapsulated all-in-one universal power supplies for Runway, Taxiway, Approach and Omni inset families
- Latest generation LEDs providing a long-lasting light source with high efficiency and low power consumption
- Protected top cover for improved durability and protection from external forces
- One single family of fixtures covering all runway, taxiway and approach applications
- IP68 rated enclosure designed for harsh environments; all fastenings are stainless steel
- Compatible with existing infrastructure allowing for direct replacement of existing LED inset fixtures

Safety

- Improved mechanical design to strengthen and consolidate components, improving the customer maintenance experience
- Fail-open option for compatibility with legacy monitoring systems and optimization of advanced control and monitoring systems
- Failed-LED Detection as required by Engineering Brief 67D
- Robust lightning protection complying with ANSI/IEEE C62.41-1991; Location Category C2 as required by FAA Eng. Brief 67. Category C2 is defined as a 1.2/50 μ S – 8/20 μ S combination wave, with a peak voltage of 10,000 V and a peak current of 5,000 A

Power Supply Options

- Non-Monitored — Power only
- Monitored — integrated Fail-open technology
- EQ with integrated ILCMS with OFDM technology for use with LINC 360 system.

Maintenance and Installation

The light fixture can be installed on an 8-inch or 12-inch base. Gaskets are sold separately. Check what gasket and bolts to order depending on base and installation.

Operating Conditions

Operating temperature	-60 °C to +55 °C / -76 °F to +131 °F
Storage temperature	-60 °C to +80 °C / -76 °F to +176 °F
Humidity	Up to 100%

3.2 Dimensions and Weight

The weight and measurement [A] depends on version of the light fixture.

Version	Weight	Dimension
TE - AM	3 kg / 6.6 lb (8 in)	203 mm / 8 in
TE - AM	6.8 kg / 15 lb (12 in)	304 mm / 12 in

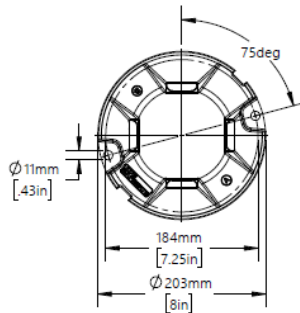
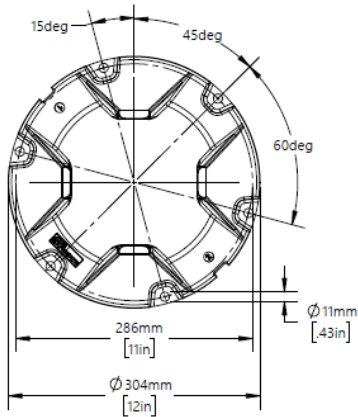
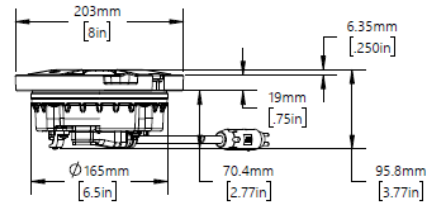
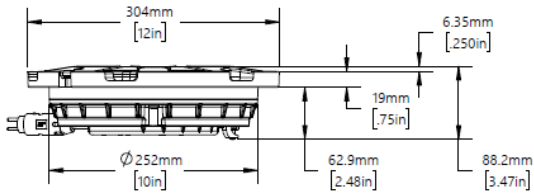

4.0 Installation

Install the inset light fixture in a base provided by ADB SAFEGATE as follows:

Note If the inset light fixture is to be installed on another type of base or adapter ring not provided by ADB SAFEGATE, contact ADB SAFEGATE.

CAUTION Use of incorrect combination of gaskets, bolts and nuts can create severe damages to the product installation and create multiple safety risks.
To obtain a safe and watertight installation the O-ring and retaining bolt stated in the document must be used.
You need to know what base the light fixture will be installed in, in order to choose the correct gasket, bolts and nuts.

4.1 Tools required

The following tools are recommended for installation.

- One Box spanner 16/17 mm.
- One torque wrench with a 16/17 mm socket.
- Two large flat headed screwdrivers for lifting the light fixture.
- One T20 Torx key.
- One brush or cloth.

Note Provided that the base intended to receive the light fixture has been properly installed, no other specific tool is required.

4.2 Installation Overview

On a shallow base.

The 8" dia. base is secured in the pavement by means of resin. Correct positioning and leveling are obtained with a jig with sighting telescope. Wires between the light and the series transformer are installed either in saw cuts in the pavement filled with resin or in pipes in the lower concrete layers. Mounting on existing or new, larger diameter bases, is made possible by means of dedicated adapter rings.

Figure 1: Installation on 8" shallow base

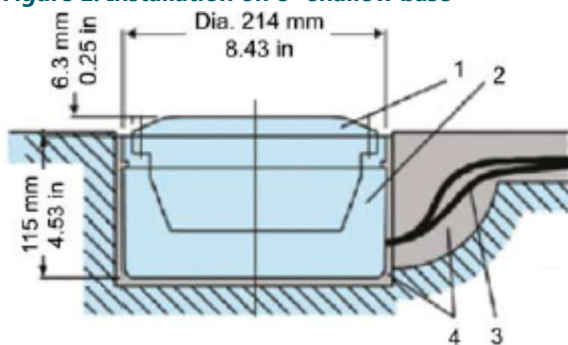

On a FAA L-868B size B steel base.

The 8" dia. light is mounted in an 8" to 12" dia. snow plow or adapter ring bolted onto the base. The 12" fixture is directly mounted without a separate ring. The bases are interconnected by means of conduits protecting the cables. See FAA AC 150/5340-30 for additional design guidance on deep base cans. The series transformer is installed under the light or in a separate pit. See data sheet A.05.120 or DS2012 for more information on base cans.

Figure 2: Diagram of the Fixture Installed in a 1-Piece Base Can

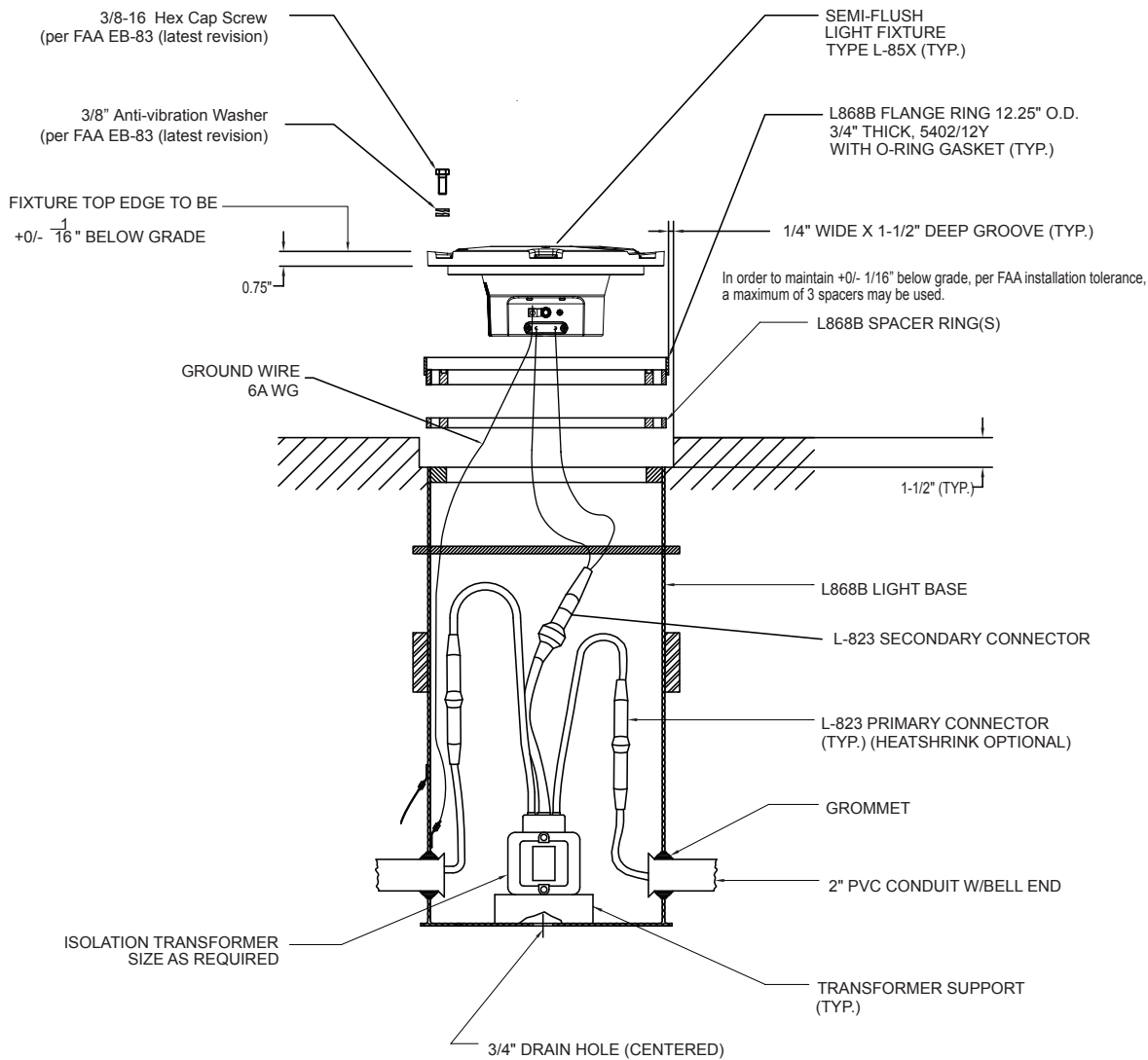
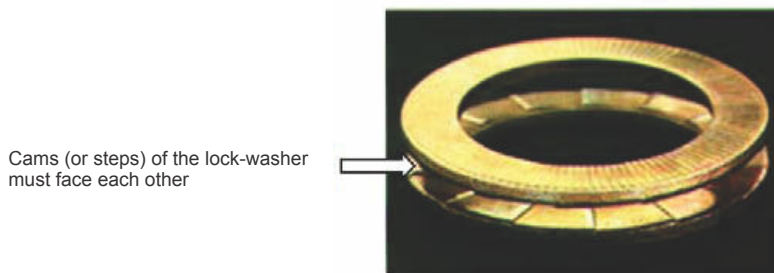

Figure 3: Anti-vibration washer example





CAUTION

Per FAA AC 150/5340-30, Chapter 10, and FAA Engineering Brief No 83 (latest revision), it is extremely important that other types of washers, such as split washers, must not be used. Failure to use properly installed anti-vibration lock washers will cause mounting bolts to become loose. The cams (or steps) of each half of the lock washer must face each other.

INTEROPERABILITY - Top cover version



Note

Please check interoperability matrix for information on torque values and compatibility towards different bases

4.3 Safety Considerations

Read the installation section of all system component manuals before installing this equipment. A thorough understanding of system components and their requirements will promote safe and efficient installation. See FAA AC 150/5340-30, Design and Installation Details for Airport Visual Aids, and site plans and specifications for field installation of runway and taxiway in-pavement lights.



CAUTION

Before you start

Allow only qualified personnel to install ADB SAFEGATE and auxiliary equipment. Use only approved equipment. Using unapproved equipment in an approved system may void FAA approvals. Observe and follow the safety instructions in this document and all other related documentation.

Make sure all equipment is rated and approved for the environment where it is being used.

- Failure to follow these warnings may result in serious injury or equipment damage.

4.4 Photobiological safety



CAUTION

Photobiological safety conforming with IEC 62471

RISK GROUP 0 or 1: Optical radiation emitted from LED lights may be harmful to the eyes. Do not stare with at the light source with bare eyes at a fixture operating at high intensity. Use protection goggles or similar protection method.

Goggles with a transmission factor not higher than 5% in the 400-530 nm band have been tested and provide adequate protection.

4.5 Verify Input Requirements and Equipment Needed

The In-pavement light fixture is designed for connection to a 6.6A or 20A series lighting circuit via an L-830 (60 Hz) or L-831 (50 Hz) isolation transformer.

Make sure you have the necessary tools and materials ready for installation (not supplied). Also consider other tools that might be needed based on site-specific conditions.

Table 1: Suggested Tools and Materials for Installation and Repair

Qty.	Description	Qty.	Description
1	Torque wrench	1	Set of screwdrivers, one with 3/8" (9.525mm) minimum blade width
1	Alignment jig		
1	Diamond-faced core drill	As needed	Silicone grease

Table 1: Suggested Tools and Materials for Installation and Repair (Continued)

1	Diamond-faced saw, 3/8" (9.525mm) thick	As needed	Joint sealing filler
1	Crimping tool	1	Pressure test fitting assembly
1	Small water suction pump	As needed	Dow Corning Molykote® 3452 or equal (P/N 67A0095) - used on top cover prism seal
2	Eyebolts, 3/8 inch (9.525mm) diameter		
1	Lifting rod, 16 inches (406mm) long	As needed	Novagard® Silicone Versilube® G322L™ (P/N 67A0009) - used on O-ring between top cover and inner pan assembly; also may be applied to four nipples of inner pan assembly to install optical assembly
1 or 2	L-830 / L-831 isolation transformer		
1	Set of fiber brushes		
1	Set of socket wrenches, 1/2" (12.7mm) drive		

4.6 Unpacking the Unit

To reduce the possibility of damaging the light assembly, unpack the light fixtures at the installation site. If damage to any equipment is noted, file a claim form with the carrier immediately.

When receiving the light fixture, open the box and verify that the characteristics of the light fixture correspond to the design requirements, such as type, color etc. When installing a light fixture where the control and monitoring function is to be activated at a later stage, make sure to register product information, such as PID/SN and position of the light fixture in, for example, a site documentation table. The information is required for remote activation and administration of control and monitoring functionality from a substation.

4.7 Inspect on delivery

1. Inspect all packings for visible damage.
2. Open every damaged box and inspect the contents for damage.
3. Immediately fill a claim form with the carrier if any fixture is damaged.
4. Store the fixture in its original packing in a protected area.



Note

If damage to any equipment is noted, file a claim form with the carrier immediately.



WARNING

Do not damage the cable insulation.



CAUTION

Do not unpack the fixture before it is at the installation site to avoid damage due to transportation and handling.

5.0 Maintenance

This section describes different steps for maintenance of the light fixture.

Before you start, make sure you have read and understand [Safety instructions](#).

Find out the location of the light unit that needs maintenance. If the purpose is to replace an existing light unit with new one, make sure that corresponding unit is available. Find the type information on the identification tag with details of name.

Spare parts are available, if required. For more information, see www.adbsafegate.com and the Spare Parts List document, or contact ADB SAFEGATE for assistance.



CAUTION

Use of incorrect combination of gaskets, bolts and nuts can create severe damages to the product installation and create multiple safety risks.

You need to know what base the light fixture will be installed in, in order to choose the correct gasket, bolts and nuts.

Failure to follow these cautions can result in equipment damage or aircraft FOD. For more information, see [INTEROPERABILITY](#).



CAUTION

When a light fixture has been removed from its base, the base must be either fitted with a cover or a spare light fixture put in its place. It is recommended that only authorized personnel disassemble fittings with prior agreement from ADB SAFEGATE.

5.1 Basic Maintenance Program

It is important to understand that even though a LED fixture requires substantially lower maintenance in regard to the replacement of the light bulbs, some parts of the light fixture remain the same and still require the same level of maintenance (prisms, top cover, bolts).

There are recommended maintenance tasks to ensure that the equipment is in correct operating condition.

Maintenance tasks

Weekly	<ul style="list-style-type: none"> • Visual inspection of the light fixture. • Removal of dust from external surfaces of the light fixture.
Monthly	<ul style="list-style-type: none"> • Check optical window for cleanliness, mechanical damage or moisture/condensation on the inside of the prism • Check for improper torque on mounting bolts. Re-torque if needed.
Yearly	<ul style="list-style-type: none"> • Detailed inspection of the light fixture • Check of the body resistance, check for mechanical damage (for example cracks around the prism windows). • Clean optical windows
Bi-yearly	<ul style="list-style-type: none"> • Check for presence of water in mounting support by unscrewing and lifting light fixture from base and check for water ingress and corrosion. Replace gasket between light fixture and base.
After snow removal	<ul style="list-style-type: none"> • Check for damaged light fixtures. Any damaged light fixtures should be replaced and brought in and properly investigated and repaired.

A daily function check is referred to in the document:

ICAO, Airport Services Manual Part 9, Airport Maintenance Practice and FAA AC 150/5340-26A, Maintenance of airport visual aids facilities.

Any issues found during maintenance tasks should be corrected accordingly and properly documented.

A proper asset management system such as ADB Safegate's ALIS can help to store/document data and can provide valuable information on local presiding conditions for preventive maintenance planning. This can then be used to minimize the need for reactive maintenance.



ALIS, ADB Safegate's new digital asset tracking, inspection and service solution, helps airports easily register airside assets, electronically schedule and track maintenance, and record maintenance and inspection tasks in compliance with ICAO and FAA standards.

Visit alis.adbsg.com.

5.2 Recommended Maintenance Program for optimal Service Life

Service Life and Inspection intervals

All products have an expected service life. Service life is the lifetime of the product and reaching the end means that it is no longer serviceable and should be replaced.

There are several key external factors that influences the service life of a product.

- Aircraft traffic movements
- Location on the airfield
- Maintenance
- Chemical usage

Air Traffic Movements (ATM)

The expected lifetime of a light fixture will be highly impacted by the traffic volume and the number of aircraft that are mechanically putting stress on the light fixtures. Airports with a higher traffic volume will have a light fixture with a shorter expected lifetime than an airport with a lower traffic volume.

The ATM can be divided into three categories for the recommendation of inspections as well as for the expected lifetime of a light fixture *.

- 0-100k movements/ year
- 100k-200k movements/ year
- >200k movements/ year

Location on the airfield

The expected lifetime of a light fixture is highly dependent on the location where it is installed on an airfield. Three different areas have been defined by color categorization that are exposed to different degree of mechanical impact. These three categories are used as a basis for the recommendation of inspections as well as for the expected lifetime of a light fixture.

- **RED** – Touch Down Area defined as 6m either side of the runway centerline for a distance starting 50m before the TDZ markings and extending to 200m beyond the TDZ markings as seen from the landing direction.
- **RED** – Rapid Exit Taxiway centerline lights from the runway centerline to 50m beyond the edge of the runway.
- **Amber** – All runway areas outside of the red areas. Also includes taxiway intersections for which more than 50% of the aircraft traffic turn more than 45 degrees.
- **Green** – Areas outside Red and Amber areas

Tip

It is recommended that there is a reliable means of recording the location history of fittings (similar to ADB Safegate ALIS) to ensure that the maximum duration in critical areas (RED) of the runway are not exceeded.

Preventive maintenance

* Based on ADB SAFEGATE's field experience and investigation made together with an independent consultant and airport.

Preventive maintenance and inspections will help to prolong the service life of a light fixture. By finding issues (e. g., bad gaskets or broken prisms) at an early stage you can mitigate and fix issue before they cause more damage and reduce the cost of the repair. You can also increase the service life of a light fixture by rotating the installation location of light fixtures in critical areas.

Regular inspections and well-defined preventive maintenance planning will help to reduce the overall maintenance cost and reduce downtime from reactive maintenance tasks.

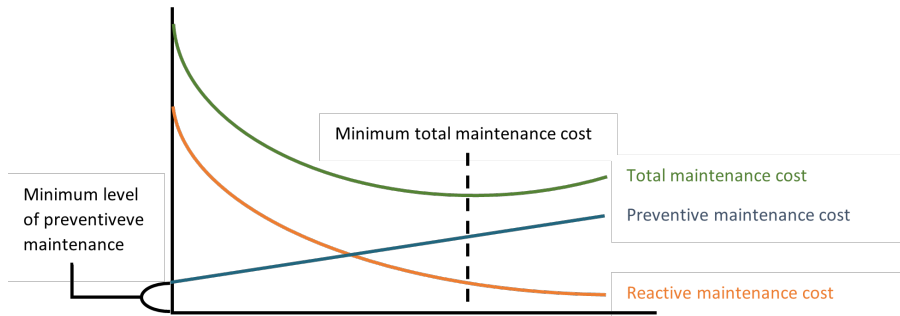

5.2.1 Recommendation

Based on the air traffic volume and location on the airfield, a matrix was created for recommended inspection intervals.

Location	RED	Amber	Green
ATM			
0-100k movements	2 Months 1 Year	6 Months 3 Years	1 Year 3 Years
100k-200k movements	2 Months 1 Year	4 Months 2 Years	1 Year 3 Years
Above 200k movements	1 Months 6 Months	2 Months 1 Year	1 Year 3 Years

Visual inspection: Visually inspect the light fixture and make sure that

- Prism is clean and no cracks are visible
- Gaskets are ok and are not deteriorating
- No moisture or condensation can be seen on the inside of the prism
- Corrosion on top cover, around the prism and bolts.
- Torquing of nuts/bolts are according to specification

Detailed Inspection: Includes visual inspection tasks and additionally the following tasks

- Unbolt the light fixture and lift it from the base for the detailed inspection
- Check for water ingress (watertight installation) and corrosion on light fixture and base (especially around the mating surfaces)
- For deep base installation (L-868) check for water ingress, if more than 6 inches please have it removed.
- Inspect light and base for damage
- Replace gasket between light fixture and base

Tip

We recommend any maintenance work that requires the light fixture to be opened to be done back in the dedicated maintenance area.

- We recommend that inspection intervals are halved for aging units that have reached more than 75 % of their expected lifetime.
- We recommend that AGL in critical areas are rotated.
- To achieve a proper location rotation and individual asset, data needs to be recorded.
- To relax the recommended frequencies of some maintenance tasks i.e. torque management, data is needed for justification.
- Policies have a direct link with the age of the AGL and should also be tracked and recorded.

Below is the recommended service life. With a proper asset management (ALIS or similar) and data capturing strategy, the below guidelines could be extended or shortened as deemed necessary via presiding local conditions.

Expected service life (only critical areas defined)

• RED Zone -, ATM < 100k	Service Life 15 years
• RED Zone -, ATM > 100k < 200K	Service Life 10 years
• RED Zone -, ATM > 200k	Service Life 7 years

 **Note**

Talk to your local sales representative if you have any questions or would require some assistance to go through local conditions and see how we can help establish a well-defined maintenance planning to optimize the expected service life of your investment.

5.3 Workshop Maintenance



CAUTION

Before you start, make sure you have read and understand [Safety instructions](#).

The following standard tools and accessories are required for maintenance of the unit:

1. One angled socket spanner of 16 or 17 mm ¹
2. One Torque limiting spanner with 16 or 17 mm socket ¹
3. One hexagonal key (Allen key) of 3, 4, and 5 mm
4. Torx 10, 20, 25, and 30
5. Two large flat blade screwdrivers
6. Silicone grease
7. CC-Patron grease
8. One brush or cloth
9. Non-alcohol based cleaner



Note

A compressor, or a manual car tire pump, equipped with a manometer is required to check the light fixture for water-tightness.

Design may differ from picture depending on application. Please follow described work flow and torque level specified as they are generic.

The workshop maintenance refers to following:

1. Replace a light fixture
2. Check the light fixture for water-tightness
3. Replace a light engine
4. Replace a prism and its gasket
5. Replace the bottom cover and converter
6. Reset the fail-open converter

¹ Depending on type and size of nuts and bolts

5.3.1 Exploded View

Figure 4: Omnidirectional Light, 4 prisms, 8-inch

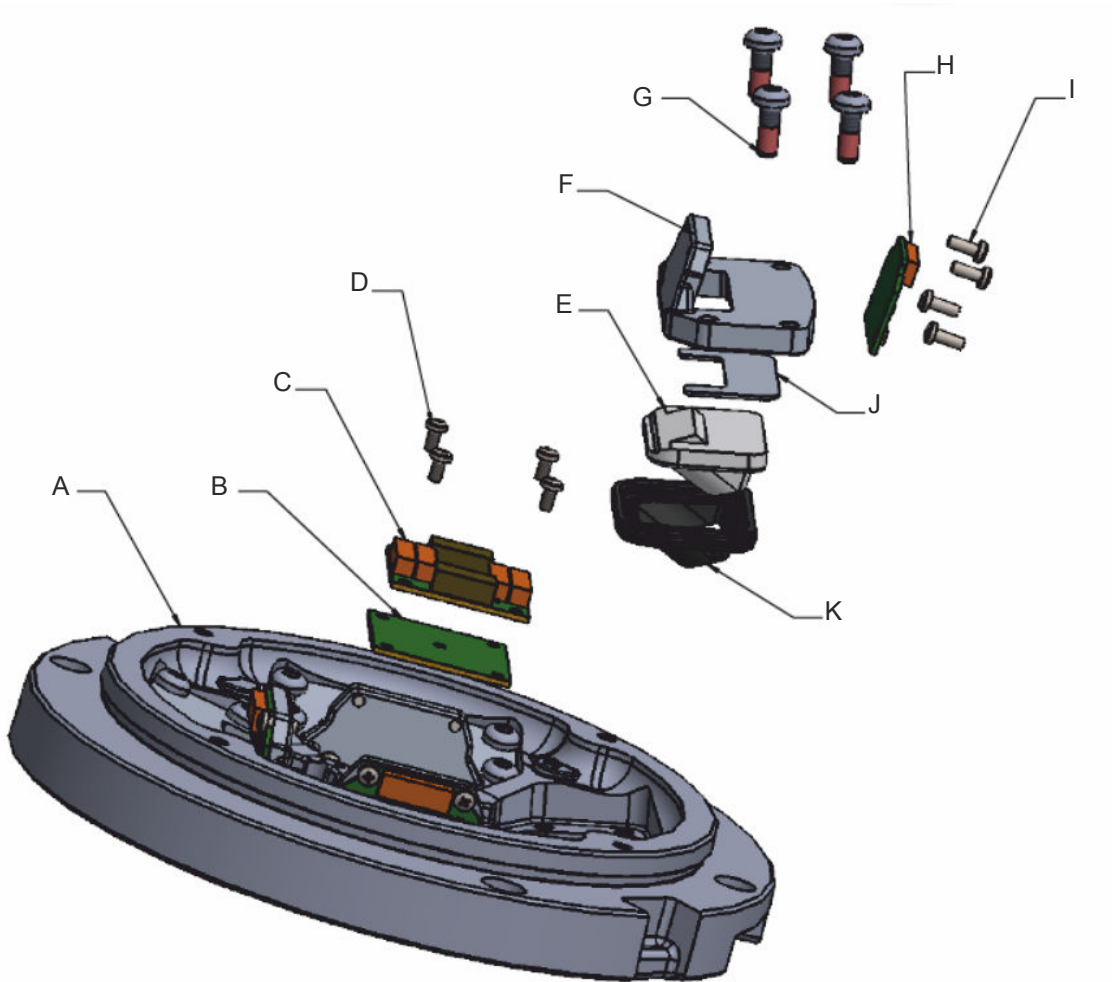

Table 2: Legend Exploded View

Call-out number	Description	Quantity
A	Top cover	1 pc
B	Isolation board	1 pc
C	Connection board	1 pc
D	Screw M3x8 DIN7985-T-A2	4 pcs
E	Prism	4 pcs
F	Holder prism	4 pcs
G	Screw M4 x6	16 pcs
H	LED board	4 pcs
I	Screw M3x8 DIN7985-T-A2	4 pcs
J	Protection prism plate	16 pcs
K	Gasket	4 pc

5.3.2 Open and close a 12-inch Fixture

Remove

1. Place the light fixture upside down and remove the four screws for the bottom cover using an Allen key 5 mm, see [Figure 5](#).
2. Lift up the housing and disconnect the LED board cable connector from the LED boards in the top cover, see [Figure 6](#).



Note

Open the light fixture cautiously, be careful not to damage the LED-board cables.

3. Remove the top cover from the bottom cover.
4. Remove the O-ring gasket from the bottom cover, see [Figure 7](#).

Figure 5: Fixture upside down

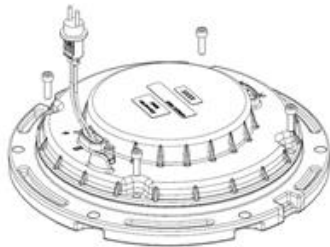

Figure 6: Lift up housing

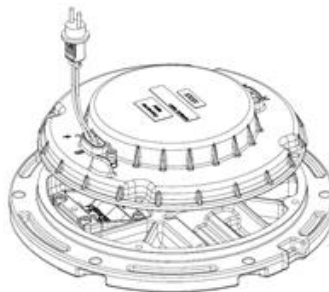
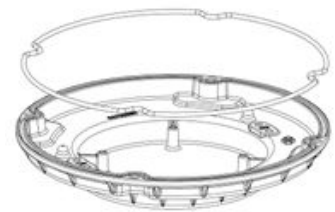

Figure 7: Remove gasket



Replace

1. Carefully clean all contact surfaces of the light fixture and of the housing.
2. Install a new O-ring gasket on the bottom cover.



Note

The O-ring gasket must be changed each time the light fixture is disassembled.

3. Connect the LED board cable connector(s) to the Supply Terminal(s) of the converter in the housing. Note the orientation and alignment of the LED board cables.

The cables should have colored wires towards each other and crossed.



Note

Before closing the light fixture, it is important to make sure the O-ring is placed correctly in the groove of the bottom cover to prepare the light fixture for water tightness checks and use in the airfield. For more information, see [INTEROPERABILITY](#).

Figure 8: Converter with 1 connector

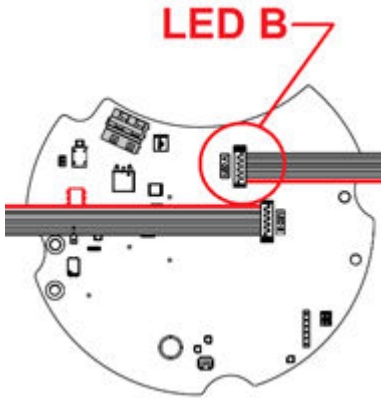

4. Put the light fixture on a surface with the top cover facing down, see [Figure 9](#).
 5. Tighten the four screws using a torque limiting spanner 5 mm Allen key or Torx key size 30 to a torque of 10 Nm (equivalent to 1.0 kg m or 10 g cm), see [Figure 10](#).
-

Figure 9: Fixture facing down

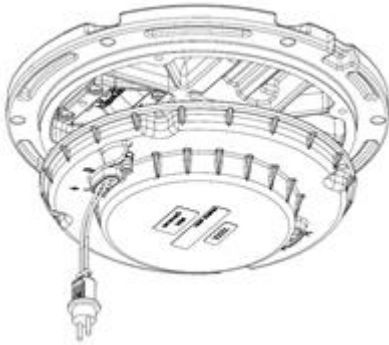
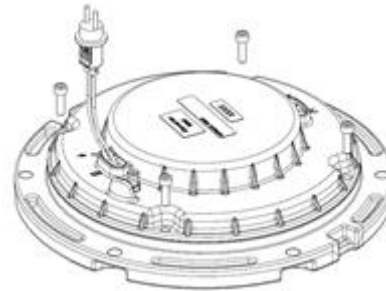

Figure 10: Tighten screws



6. Check the light fixture for water-tightness. For more information, see [Checking the Light Fixture for Water-Tightness](#).
-

5.3.3 Closing an 12-inch Light Fixture

Replacement

1. Carefully clean all contact surfaces of the light fixture and of the housing.
2. Install a new inner pan gasket on the bottom cover.

Important

The inner pan gasket must be changed each time the light fixture is disassembled.

3. Connect the LED board cable connector(s) to the supply terminal(s) of the converter in the housing.

NOTICE

Note the orientation and alignment of the LED board cables.
The cables should have colored wires towards each other and crossed.

Note

Refer to [Figure 11](#) figure.

4. Place the top cover over the bottom cover, align A and B sides on the top cover with the corresponding sides on the bottom cover.

Figure 11: Converter with 1 connector

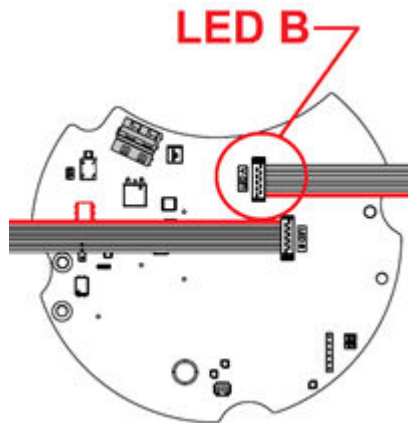

Important

Before closing the light fixture, it is important to make sure the inner pan gasket is placed correctly in the groove of the bottom cover to prepare the light fixture for water tightness checks and use in the airfield.

5. Put the light fixture on a surface with the top cover facing down.

Note

Refer to [Figure 12](#) figure.

6. Tighten the four screws using a torque limiting spanner 4 mm Allen key to a torque of 8 Nm (equivalent to 0.8 kg m or 8 g.cm).

Note

Refer to [Figure 13](#) figure.

Figure 12: Fixture facing down

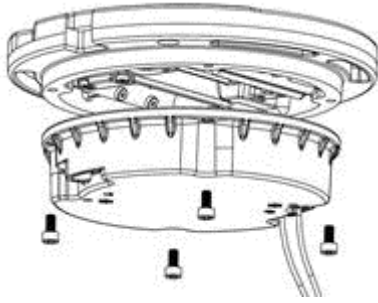
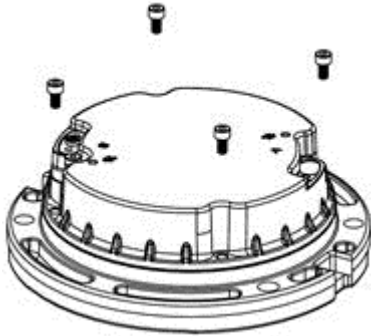

Figure 13: Tightening screws



7. Check the light fixture for water-tightness.



Note

Refer to [Checking the Light Fixture for Water-Tightness](#) section for more information.

5.3.4 Opening an 8-inch Fixture

Removal

1. Place the light fixture upside down and remove the four screws for the bottom cover using an Allen key 4 mm.

i Note
Refer to [Figure 14](#) figure.

2. Lift up the housing and disconnect the LED board cable connector from the LED boards in the top cover.

i Note
Refer to Lifting [Figure 15](#) figure.

i NOTICE
Open the light fixture carefully so that you do not damage the LED-board cables.

3. Remove the bottom cover from the top cover.
4. Remove the O-ring gasket from the bottom cover.

i Note
Refer to [Figure 16](#) figure.

Figure 14: Fixture upside down

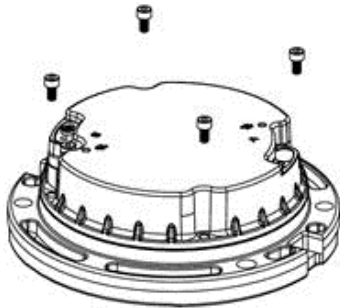

Figure 15: Lifting up housing

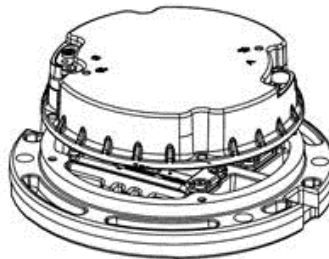
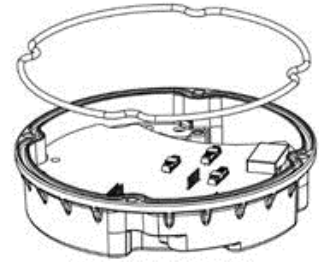

Figure 16: Removing gasket



5.3.5 Closing an 8-inch Light Fixture

Replacement

1. Carefully clean all contact surfaces of the light fixture and of the housing.
 2. Install a new inner pan gasket on the bottom cover.
-

Important

The inner pan gasket must be changed each time the light fixture is disassembled.

3. Connect the LED board cable connector(s) to the supply terminal(s) of the converter in the housing.
-



NOTICE

Note the orientation and alignment of the LED board cables.
The cables should have colored wires towards each other and crossed.



Note

Refer to [Figure 17](#) figure.

4. Place the top cover over the bottom cover, align A and B sides on the top cover with the corresponding sides on the bottom cover.

Figure 17: Converter

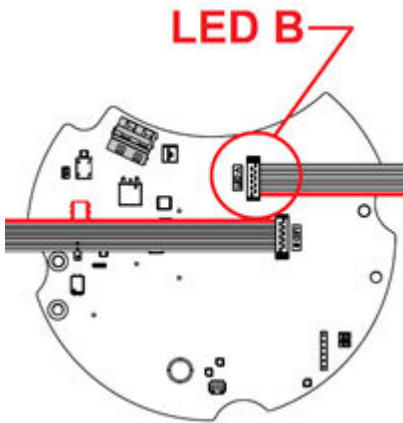

Important

Before closing the light fixture, it is important to make sure the inner pan gasket is placed correctly in the groove of the bottom cover to prepare the light fixture for water tightness checks and use in the airfield.

5. Put the light fixture on a surface with the top cover facing down.
-



Note

Refer to [Figure 18](#) figure.

6. Tighten the four screws using a torque limiting spanner 4 mm Allen key to a torque of 8 Nm (equivalent to 0.8 kg m or 8 g.cm).
-



Note

Refer to [Figure 19](#) figure.

Figure 18: Fixture facing down

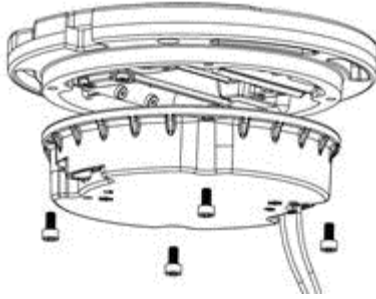
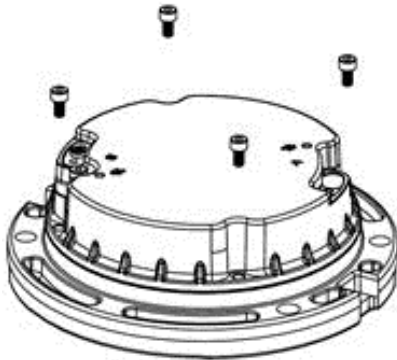

Figure 19: Tightening screws



7. Check the light fixture for water-tightness.



Note

Refer to [Checking the Light Fixture for Water-Tightness](#) section for more information.

5.3.6 Checking the Light Fixture for Water-tightness

Tools to be used:

- Flat head screwdriver
- For water tight testing, pressure test fitting tool to be used : 44A6104/A

Execute the following procedure to test for leaks:

1. Remove the Pressure-relief Screw.

Refer to the image below.

Figure 20: Pressure-relief screw removal

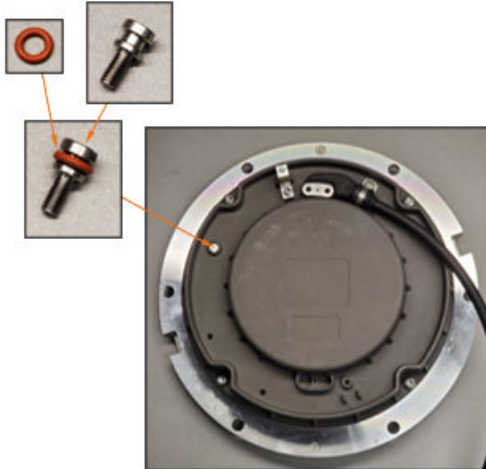

2. Screw the pressure test fitting to the Pressure-relief Port.



NOTICE

The Pressure-relief Port is the opening you created when the pressure relief screw was removed.

3. Screw the fitting hand-tight.

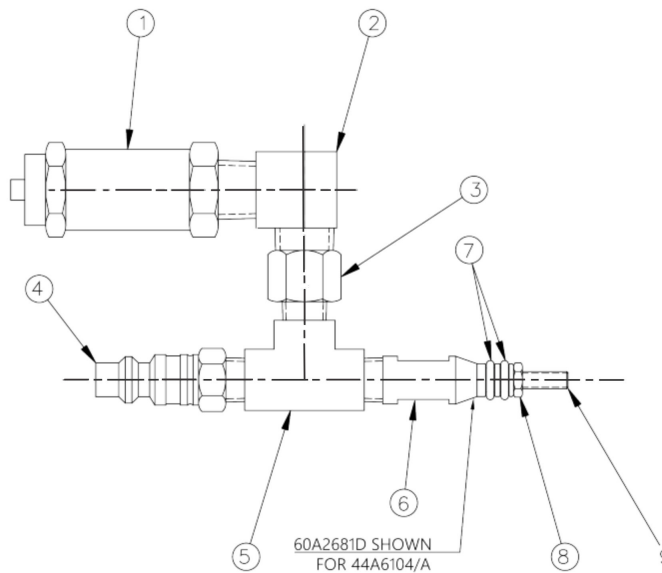

Call-out	Description
1	Pop — safety valve
2	90 deg., elbow, female X male, brass, 1/4"
3	Adapter, female — male, 1/4 x 1/8, brass
4	Sleeve — lock hose plug, 1/4" coupler
5	Tee, brass, 1/8
6	Pressure test fitting, body

Call-out	Description
7	O-ring, silicone, size 008, 1/16 W X 3/16
8	M4 Hex Jam nut, 18-8 SS
9	Pressure test fitting stud

4. Pressurize to 20 psi (130 kPa).
5. Submerge the pressure test fitting in a water tank.
6. Wait 3 minutes and check if air leaks out of the light.

If air leaks out of the light fixture (between the Bottom Cover and the top plate or between the prism and top plate or watertightness valve and top plate), the light fixture is not watertight and must be repaired. Release the air from the light. Disassemble the light fixture and re-check the mating surfaces and gaskets. Assemble the light fixture and perform the water-tightness test again.

7. Depressurize and reinstall the pressure release screw (1) at 26 in-lbs (3 Nm), if the fixture is watertight.



DANGER

Never exceed a pressure of 22 psi (150 kPa) inside the light fixture. A higher pressure may cause injuries and damage the light.

5.3.7 Replace a Light Engine in a 12-inch and an 8-inch Fixture

Remove

1. Disassemble the light fixture.
2. Detach and remove the LED board holder, including 4 screws from the body, using a 4 mm Allen key.

Figure 21: Light engine

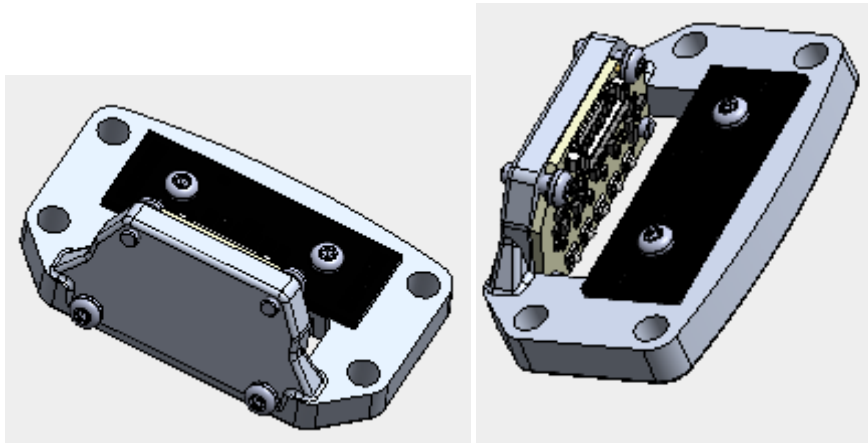

OMNI			8"							12"								
Application	App ID	FAA LIGHT	CAO LIGHT	MOS LIGHT	BLUE	GREEN	RED	WHITE	YELLOW	INFRARED BLUE	INFRARED YELLOW	BLUE	GREEN	RED	WHITE	YELLOW	INFRARED BLUE	INFRARED YELLOW
AIRCRAFT MAINWAY	AM				B	F	R	W	Y	B	Y	B	F	R	W	Y	B	Y
TAXIWAY INTERSECTIONS (LE)	LE	L 852E					300mA 23V 23V		420mA 23V 23V							420mA 23V 23V		
TAXIWAY INTERSECTIONS (L/F COLMATOR 407178290 080)	LF	L 852F																
NAVAIR TAXIWAY INTERSECTIONS (NH)	NH	L 852H										300mA 23V 23V						
NAVAIR TAXIWAY INTERSECTIONS (NL)	NL	L 852L										150mA 23V 23V						
MOS RUNWAY EDGE (RL)	RL													350mA 23V 23V				
MOS RUNWAY EDGE (RM)	RM													600mA 23V 23V				
TAXIWAY EDGE (TE)	TE	L 852T			100mA 01E 01E				100mA 01V 01V	100mA 01E 01E	100mA 01V 01V	100mA 01B 01B				100mA 01V 01V	100mA 01E 01E	100mA 01V 01V

NOTES:
 2. PARAMETER FILE DRIVE CURRENT
 3. PARAMETER FILE CONFIG. CODE
 4. BLANK LED BOARD

Replace

1. Attach the new LED board holder, including screws. The screws on the LED holder shall be tightened gently in sequence, following number 1-4, see [Figure 22](#).
2. Tighten the same screws to a torque of 4.5 Nm, following number 5-8, see [Figure 22](#).

Figure 22: Tighten screws

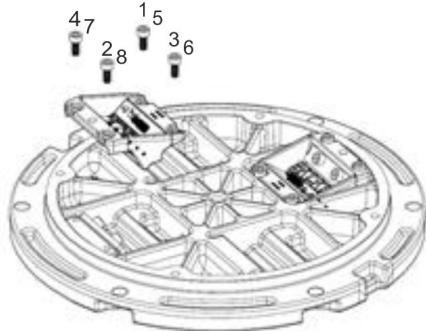

3. Connect the LED-cable(s) to the LED-board(s), note the cable orientation.
4. Assemble the light fixture.

5.3.8 Replacing the Top Cover of a 12-inch Fixture

i NOTICE Top covers are delivered without the LED boards. LED boards have to be ordered separately.

i Note When a top cover is replaced, new LED boards (which are mounted on the brackets) have to be mounted. For LED board replacement new gaskets and blue spacers are required. They are available separately.

1. Open the light: Disconnect the top cover from the bottom cover.
-

i Note Refer to the [Figure 23](#) figure.

Figure 23: Top cover with bottom cover

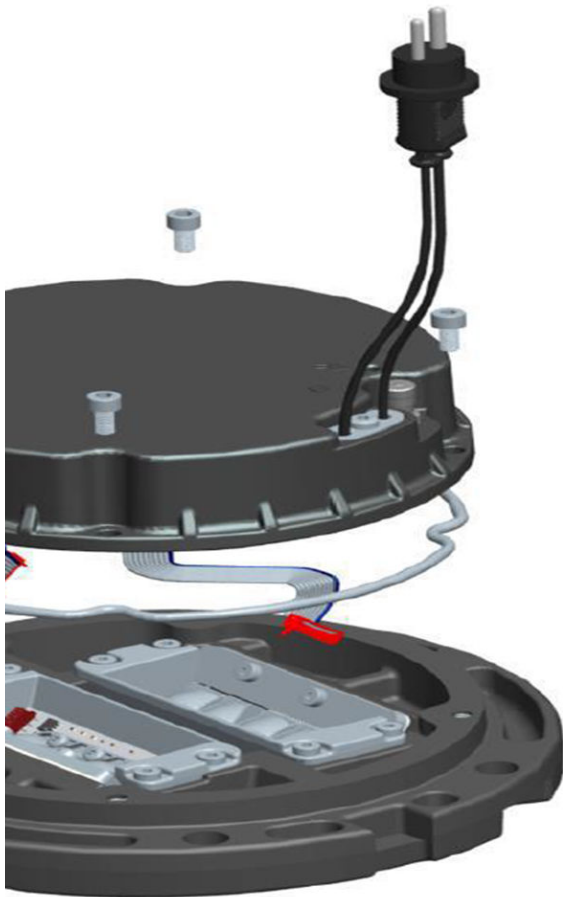

2. Remove the cables from the assembly.
 3. Disconnect the inner pan gasket, the prism gasket, the prism protection plate (blue spacer), the prism and the LED kit from the cover. The gaskets and the prisms have to be replaced after delivery.
You have to remove the prism holder (bracket) to mount the LED board.
-

i Note Follow the instruction on mounting a LED board in the [Replacing the LED Board](#) section.

4. Place the components on the bottom cover.
5. Reconnect the parts and the cables.
6. Place the bottom cover on the top cover with component and connect them with the screws and connectors.
7. Close the fixture.

5.3.9 Replacing the Top Cover of an 8-inch Fixture

i NOTICE
Top covers are delivered without the LED boards. LED boards have to be ordered separately.

i Note
When a top cover is replaced, new LED boards (which are mounted on the brackets) have to be mounted. For LED board replacement new gaskets and blue spacers are required. They are available separately.

1. Open the light: Disconnect the top cover from the bottom cover.

i Note
Refer to the [Figure 24](#) figure.

Figure 24: Top cover with bottom cover

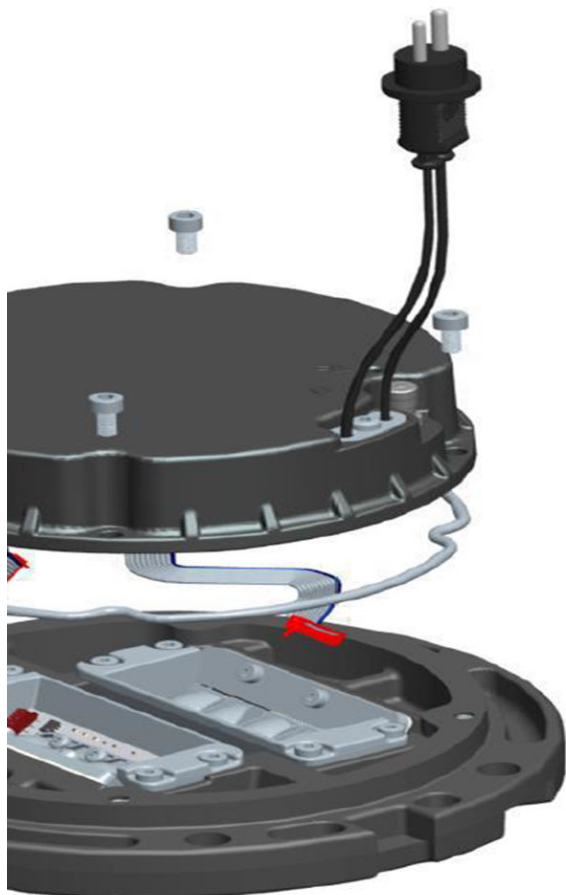

2. Remove the cables from the assembly.
3. Disconnect the inner pan gasket, the prism gasket, the prism protection plate (blue spacer), the prism and the LED kit from the cover. The gaskets and the prisms have to be replaced after delivery.

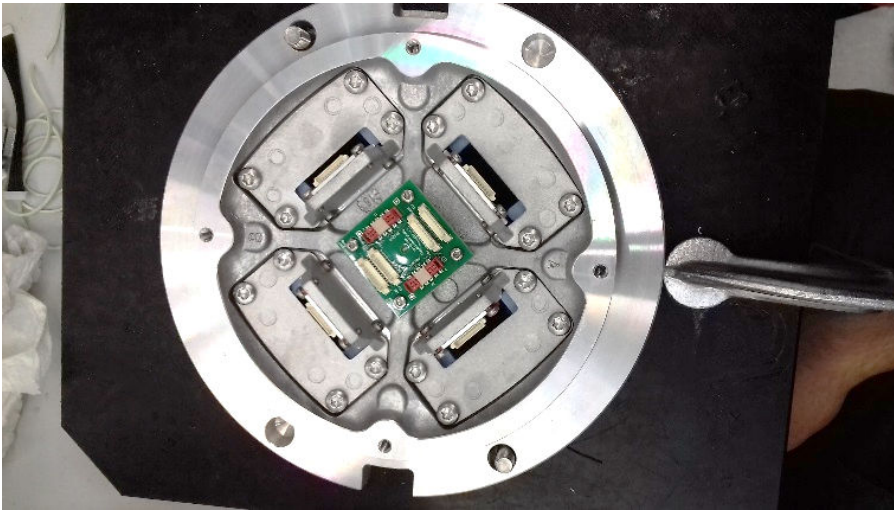
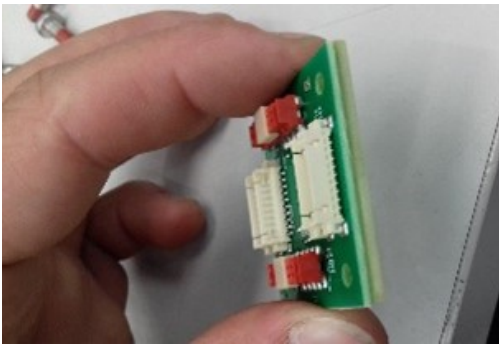

1. Disconnect the red connectors from the connection board.
2. Loosen the cables.
3. Remove the old connection board with the isolation board from the top cover.
4. Insert the new connection board with the isolation board on the top cover.
5. Connect the cables to the connection board.
6. Connect the connection board with the isolation board on the top cover.

i Note

There are two different types of connectors (entry cables) that are led from the converter to the LED board (and not to the LED modules). The black one (4 pieces of 70 mm each) connect the connection board with the LED boards and the red connectors (2 pieces of 180 mm each) connect the connection board with the converter. The cables are available separately in a cable kit.

Figure 26: Two connector types (replaceable)

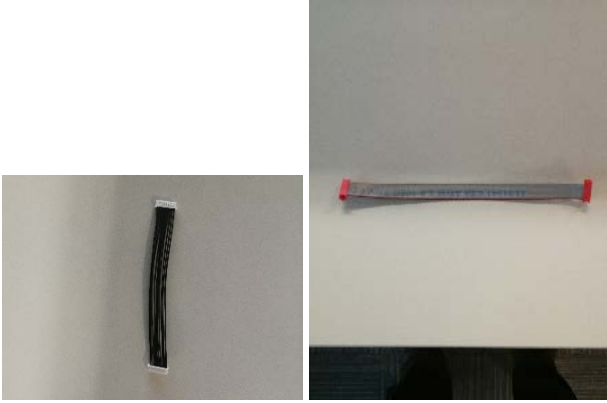
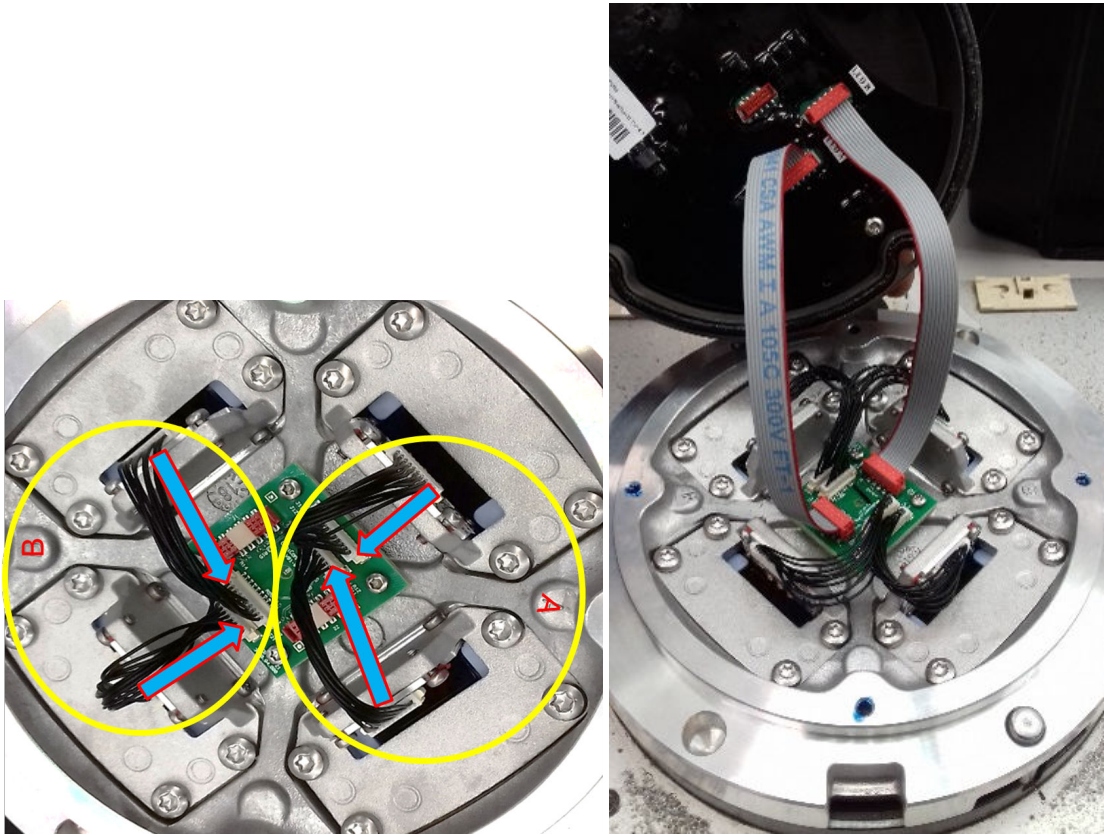

Figure 27: Red and black cable connections



7. Close the fixture.

5.3.11 Replacing the Connection Board of a 12-inch fixture

The connection board number b) is included in the converter board assembly kit. The connection board is assembled with the isolation board (split board) number a) on the top cover. This combination is fixed together with 4 screws (call-out c)).

Figure 28: Replacing the connection board

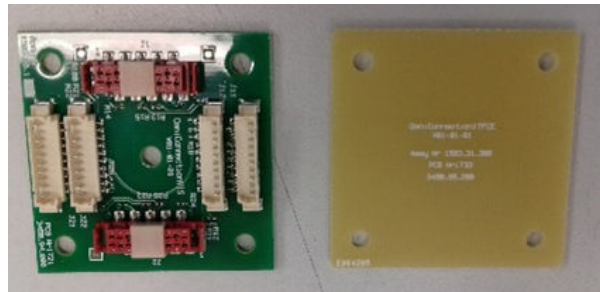
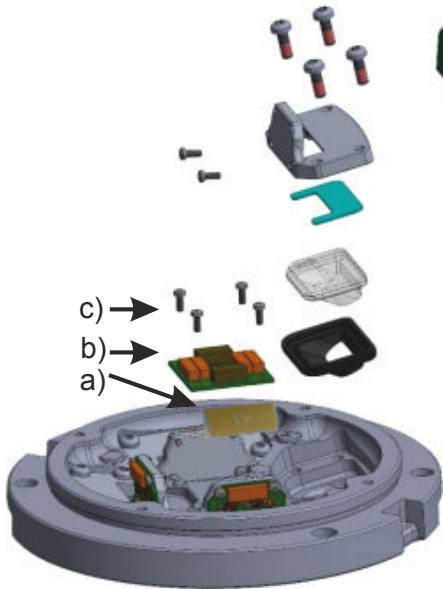

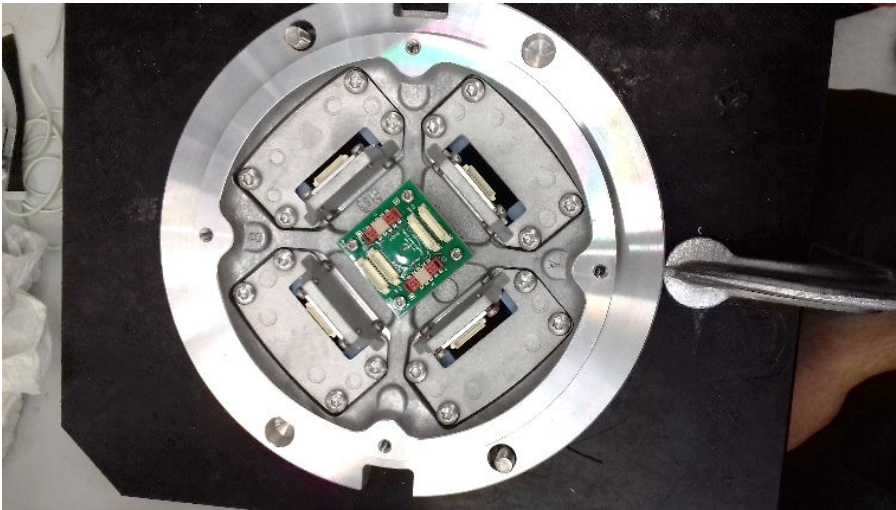
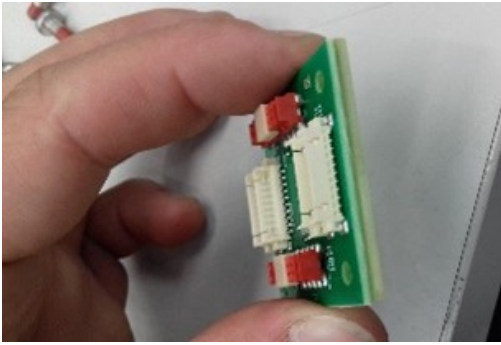

1. Disconnect the red connectors from the connection board.
2. Loosen the cables.
3. Remove the old connection board with the isolation board from the top cover.
4. Insert the new connection board with the isolation board on the top cover.
5. Connect the cables to the connection board.
6. Connect the connection board with the isolation board on the top cover.



Note

There are two different types of connectors (entry cables) that are led from the converter to the LED board (and not to the LED modules). The black one (4 pieces of 70 mm each) connect the connection board with the LED boards and the red connectors (2 pieces of 180 mm each) connect the connection board with the converter. The cables are available separately in a cable kit.

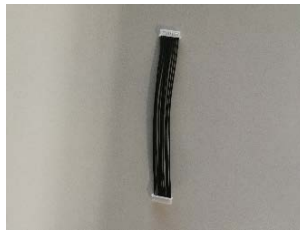
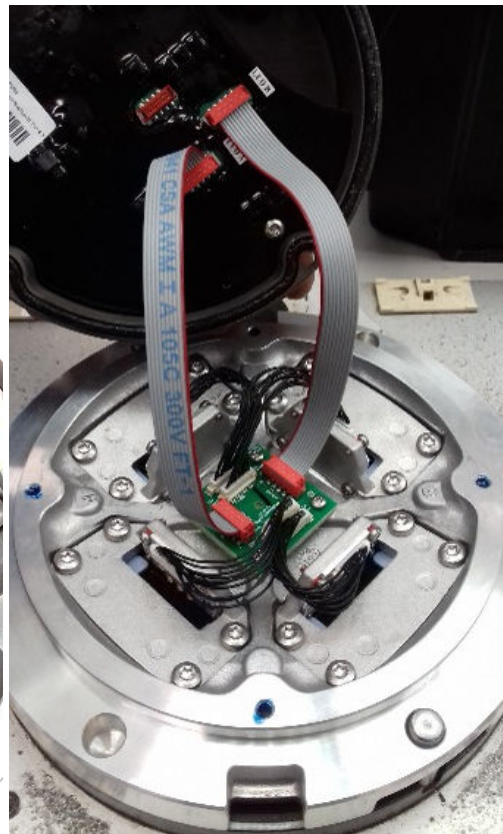
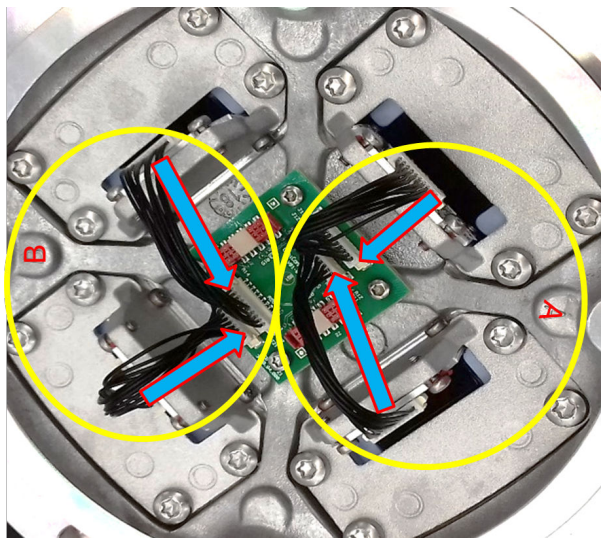

Figure 29: Two connector types (replaceable)



Figure 30: Red and black cable connections



7. Close the fixture.

5.3.12 Replacing the LED Board

The LED board is included in the LED kit. LED boards are delivered mounted on the LED prism holders (brackets). You can mount the LED board without disassembling the connection board.

i NOTICE

Replace blue spacer and prism gasket to mount the LED board when a new fixture is delivered. The spacers and gasket that are mounted upon receipt are only mounted as a transportation protection. Make sure you throw them away!

1. Remove the brackets from the prisms being in place when they are delivered to mount the LED board.



Note

Refer to [Figure 31](#) figure.

Figure 31: LED sub assembly (Optical assembly)

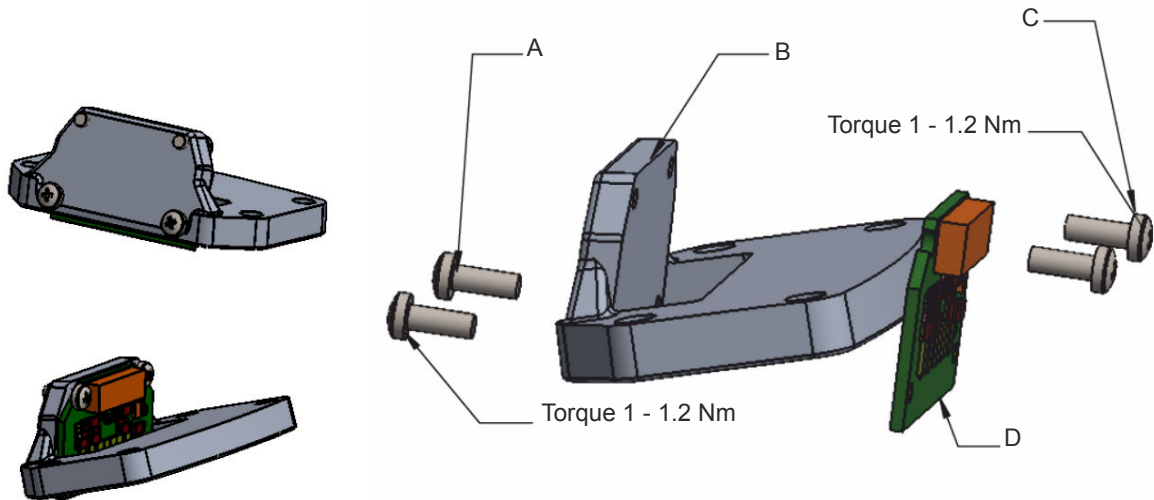

2. Put the new LED board (call-out D) onto the assembly with cables.
3. Connect the cables with the LED board.
4. Set the LED optical assembly with the prism protection plate and the prism on the gasket (prism assembly kit).
5. Put the prism assembly onto the top cover.
6. Close the fixture.

5.3.13 Replace a Prism and its Gasket in a 12-inch Fixture

Remove

1. Disassemble the light fixture.
2. Detach and remove the LED board holder, including 4 screws from the body, using a 4 mm Allen key, see [\[fig 1.x\]](#).

3. Remove the Teflon and steel protective plates from the LED board holder.
4. Remove the prism and its gasket, see [fig 1.x].

Figure 32: Remove LED board holder

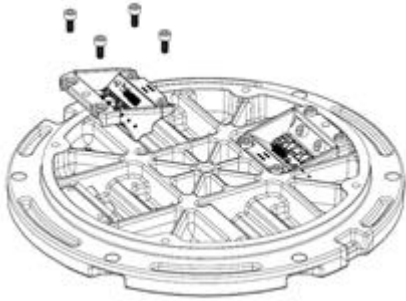

Figure 33: Remove prism and gasket

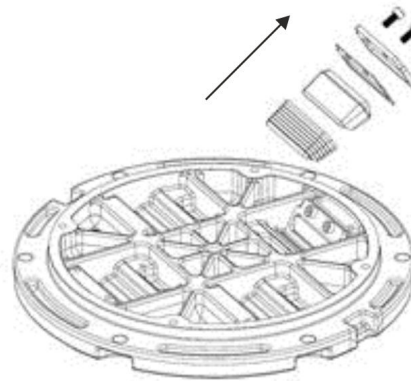

Figure 34: Exploded View

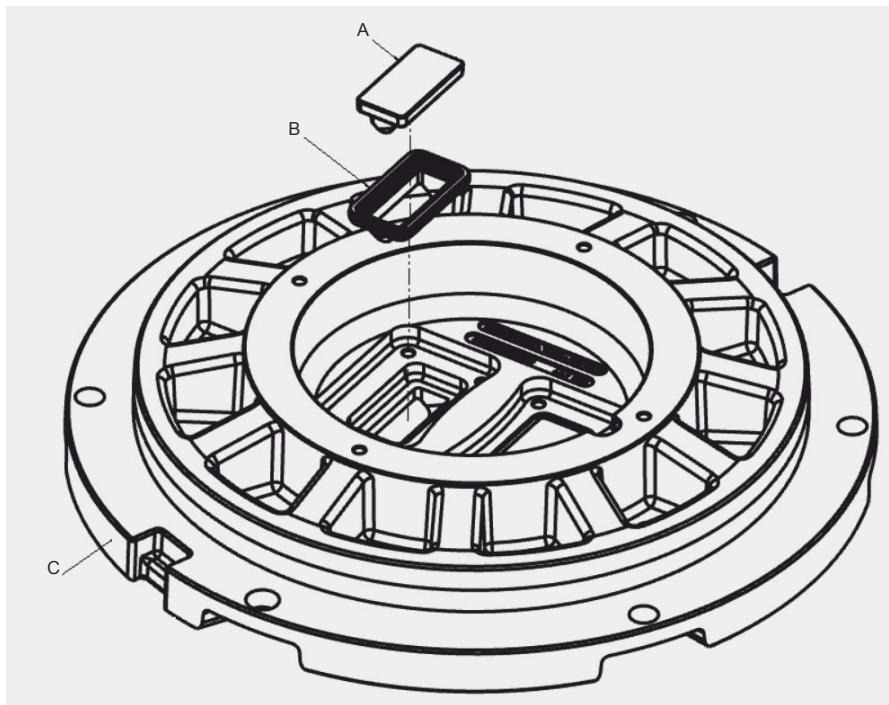

Table 3: Exploded View Legend — Top Cover Assembly, 12 inch

Call-out	Description	Part Number
A	Prism See BOM for specific part number for 4072.4X.XXX prism.	4072.4X.XXX
B	Prism Gasket	4072.40.421
C	Top Cover See BOM for specific part number for MC000XX-XXX-01 top cover.	MC00084-XXX-01

Replace

1. Lubricate the new prism gasket with CC Patron grease.
2. Place the prism gasket in the prism opening in the top cover.
3. Put the new prism into the new prism gasket, then push it all the way into the opening and hold for about a minute. See [Figure 35](#).

Figure 35: New prism into prism gasket

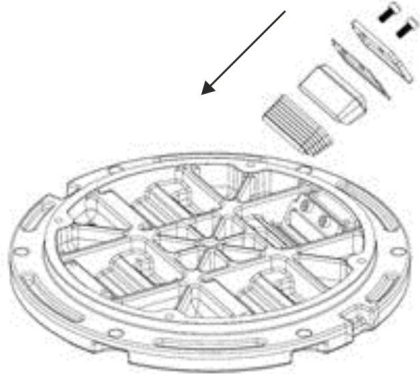

4. Check that the O-ring of the prism gasket is even in the chambered area.
5. Place the new Teflon protective plate and steel plate over the prism and prism gasket and tighten the two M5x12 screws to a torque of 4.5 Nm.
6. Looking from above, make sure the prism edge is parallel with the prism holder, see [Figure 36](#).

Figure 36: Prism holder edge

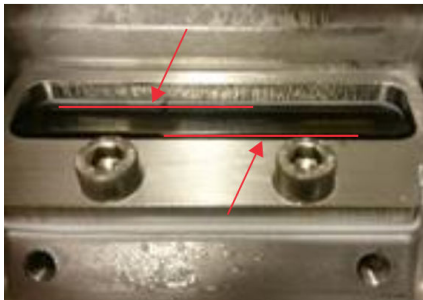

7. Use alcohol based cleaner to remove any grease or dust from the prism.
8. Attach the LED board holder, including screws, and gently tighten the screws on the LED holder in sequence following number 1-4, see [Figure 37](#).
9. Tighten the same screws to a torque of 4.5 Nm following number 5-8, and re-tighten the two screws on the steel plate to 4.5 Nm. See [Figure 37](#).

Figure 37: Tighten screws in sequence

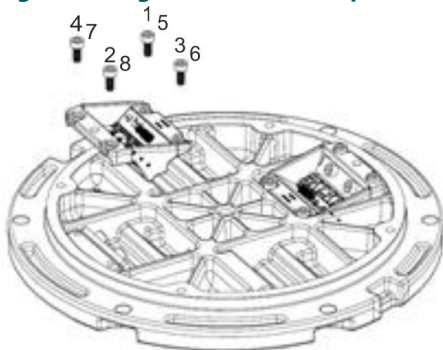

10. Assemble the light fixture.
11. Cut off any protruding prism gasket on the outside of the top cover.

5.3.14 Replacing a prism, its gaskets and the blue spacers (prism protection plates) in a 8-inch fixture

Removal

Important

Make sure that you replace all 4 prisms in case you replace a prism. It is required to replace them when there is water in the fixture or when the prism is cracked!

i NOTICE

Preventive maintenance info: Make sure that you replace all 4 prisms when one LED is defective.

1. Disassemble the light fixture:
 - a. Disassemble the prism holder (bracket) from the top cover.

i NOTICE

Every time the prism holders are replaced, the prism protection plates (blue spacers) require replacement, too.

- b. Remove bracket number d) and replace parts a), b) and c).

i Note

Refer to [Figure 38](#) figure.

Restriction

As soon as part d) is replaced, part a) and c) must be replaced, too. If this action is not executed, the fixture will not be watertight any more!

Figure 38: Exploded view - prism replacement

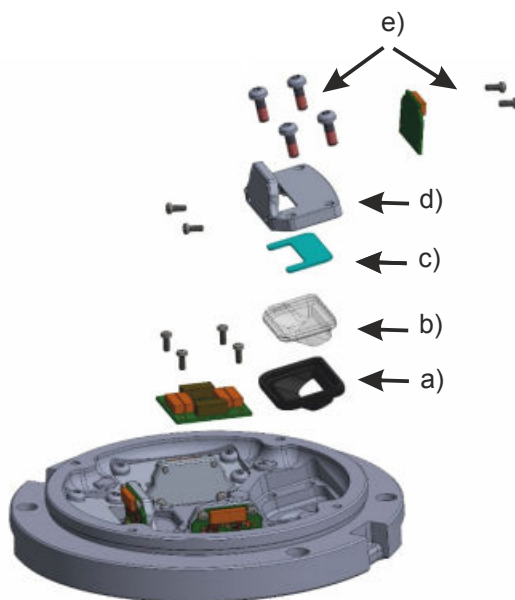

2. Detach and remove the LED board holder, including 4 screws from the body, using a 3 mm Allen key. See [Figure 39](#).

Remember

Never reuse the screws! The screws number e) are included in the kit (not as spare parts).



Note

Refer to [Figure 38](#) figure.

3. Remove the Teflon and steel protective plates from the LED board holder.
 4. Remove the prism and its gasket, see [Figure 40](#).
-

Figure 39: Remove LED board holder

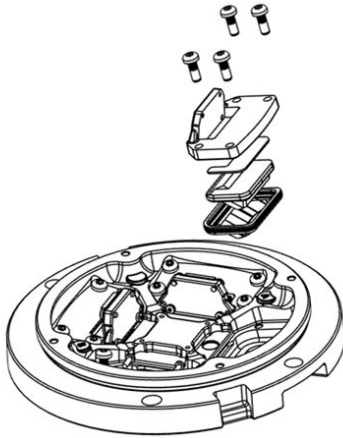
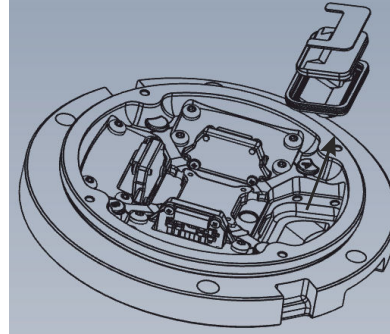

Figure 40: Remove prism and gasket



Replacement



NOTICE

The prism gaskets and the protection prism plate require replacement every time a prism is replaced. That means that when 4 prisms have to be replaced, 4 gaskets and prism protection plates require replacement, too.

1. Lubricate the new prism gasket with CC Patron grease.
2. Place the prism gasket in the prism opening in the top cover.
3. Put the new prism into the new prism gasket, then push it all the way into the opening and hold for about a minute. See [Figure 41](#).

Figure 41: New prism into prism gasket

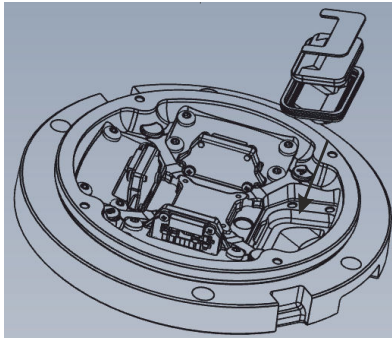

4. Check that the O-ring of the prism gasket is even in the chambered area.
 5. Place the new Teflon protective plate and steel plate over the prism and prism gasket and tighten the two M4 screws to a torque of 4.5 Nm.
-

6. Looking from above, make sure the prism edge is parallel with the prism holder, see [Figure 42](#).

Figure 42: Prism holder edge

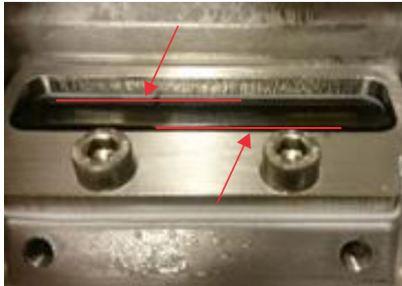

7. Use alcohol based cleaner to remove any grease or dust from the prism.
8. Attach the LED board holder, including screws. The screws on the LED holder shall be tightened to a torque of 4.5 Nm, in sequence 1-4. Tighten the same screws again to a torque of 4.5 Nm, in sequence 5-8. See [Figure 43](#).



Note

The torquing sequence must be respected as it ensures correct positioning of the prism.

Figure 43: Tighten screws in sequence

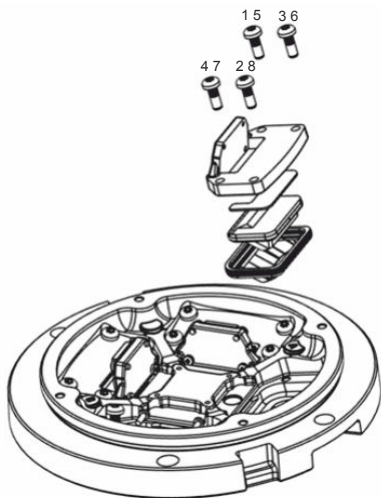

9. Re-tighten the two screws on the steel plate to 4.5 Nm. See [Figure 43](#).
10. Assemble the light fixture.

Make sure the gasket is fitted in correctly.



Note

Refer to [Figure 44](#) figure.

Figure 44: Correct gasket position





Note

Make sure you check the fixture for watertightness every time you have to replace a spare part!

5.3.15 Replace the Bottom Cover and Converter of a 12-inch Fixture

Remove

1. Disassemble the light fixture.
2. From inside the housing, disconnect all cables from the LED board.

Replace

1. Place the new gasket on the new bottom cover with converter, see [Figure 45](#).

Figure 45: Gasket

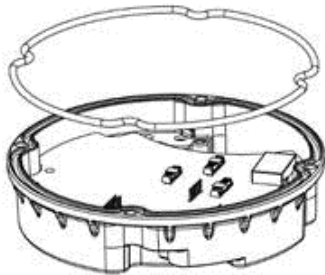

2. Connect the LED board cable(s). Note the orientation and alignment of the cables in [Figure 46](#) and [\[fig 1.x\]](#).
-

Figure 46: Converter with 1 connector

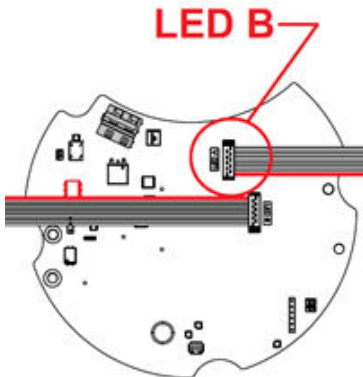

3. Assemble the light fixture.
-

5.3.16 Replace the Bottom Cover and Converter of a 8-inch Fixture

Removal

1. Disassemble the light fixture.
2. From inside the housing, disconnect all cables from the LED board.

Replacement

1. Place the new gasket on the new bottom cover with the converter.
 2. Connect the LED board cable(s). Note the orientation and alignment of the cables in [Figure 47](#) and [#unique_49/unique_49_Connect_42_Conv2con](#) figures.
-



NOTICE

Make sure that light fixtures with only one LED-cable is connected to the LED B-channel.

Figure 47: Converter with 1 connector

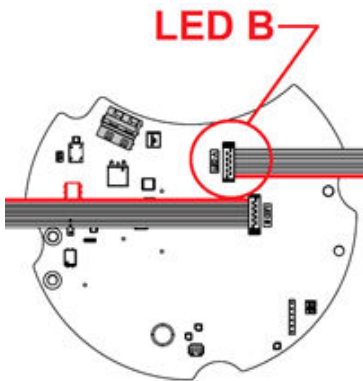

3. Assemble the light fixture.

5.3.17 Reset the Fail-Open Converter

Parts

- Fuse resistor spare part kit: 6132.00.250 (20pcs)

Info

- Converter has 2 fuse resistors

Reset / replace the fuse resistors

1. Disconnect and disassemble the light fixture.
2. Locate the fuse resistors, see [Figure 48](#) and [\[fig 1.x\]](#).

Figure 48: Converter

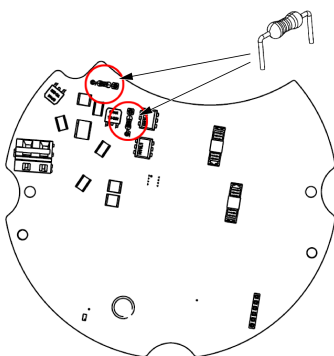

3. Remove the fuse resistors by pulling away from the converter.
 - a. Always replace both fuse resistors at the same time.
4. Dispose the old fuse resistors.
5. Place the legs of the new fuse resistors in the sockets.
6. Assemble the light fixture and perform a functional test.

6.0 Ordering codes

6.1 Ordering Code L-852T(L) LED Taxiway Edge

Ordering Code	R	S	T	E									
Primary Standard 1 = FAA / ICAO ¹	●												
Market Specific 0 = None 1 = Buy American Preference (BAP) ²		●											
Dimensions 1 = 8 inch (203 mm) diameter 2 = 12 inch (305 mm) diameter, 11.25 inch BC (285 mm; L-868B mount) ³			●										
Prism P = 4 protected prisms				●									
Beam Orientation 3 = Omnidirectional					●								
Toe-in N = Not applicable						●							
Color B = Blue Y = Yellow ⁵ 1 = Infrared Blue ⁵ 2 = Infrared Yellow ⁵							●						
N = Not applicable								●					
Power and Monitoring S = 2.8 - 6.6 A, non-monitored — power only M = 2.8 - 6.6 A, Fail-open monitoring R = 2.8 - 6.6 A, EQ integrated LINC 360									●				
Connector and Cable 1 = 1 x Style 6 2-pole plug, 2 individual wires ⁴ 2 = 1 x Style 1 2-pole plug, 2-core cable ⁴ 5 = 1 x Flat 3-pole plug, 3 individual wires ⁵										●			
Options 0 = None 1 = Arctic Kit											●		
Version Control 1 = First version ⁶ 2 = Second version												●	

Ordering Code Notes

EQ light fixtures are only available as a one connector option.

¹ Includes standards MOS (Intermediate Hold Position)/ UFC/ NAVAIR.

² Required for FAA when using AIP funds.

³ L-867B base can mounting — Use 8-inch fixture with AA132820 adapter ring. Existing L-867B base must have a top flange with a 9.25 inch ID. L-867B bases made prior to 2007 will have a top flange with a 8-inch ID. Use 127A01125FTO adapter ring with 8-inch fixture for these applications.

⁴ All Style 1 corded fixtures will include a ground lug. All Style 6 corded fixtures will be provided without a ground lug.

⁵ Not ETL submitted

⁶ First Version was only manufactured at Columbus Facility

6.2 Ordering Code Apron Maneuvering

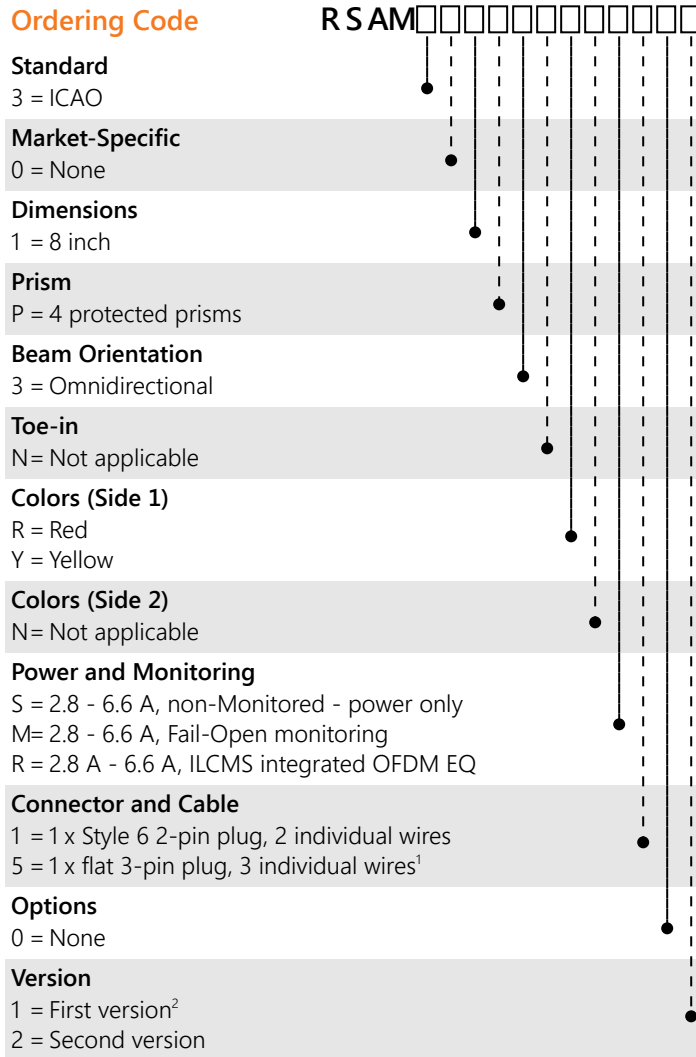

Ordering Code Notes

¹French 3-pin plug (1F).

²First Version was only manufactured at Columbus Facility.



Note

Note : Deep base and / or adapter rings to be ordered separately.

7.0 Spare Parts

For more information, see www.adbsafegate.com and the spare part lists, or contact ADB SAFEGATE for assistance.

7.1 Exploded View

Figure 49: Omnidirectional Light, 4 prisms, 12-inch

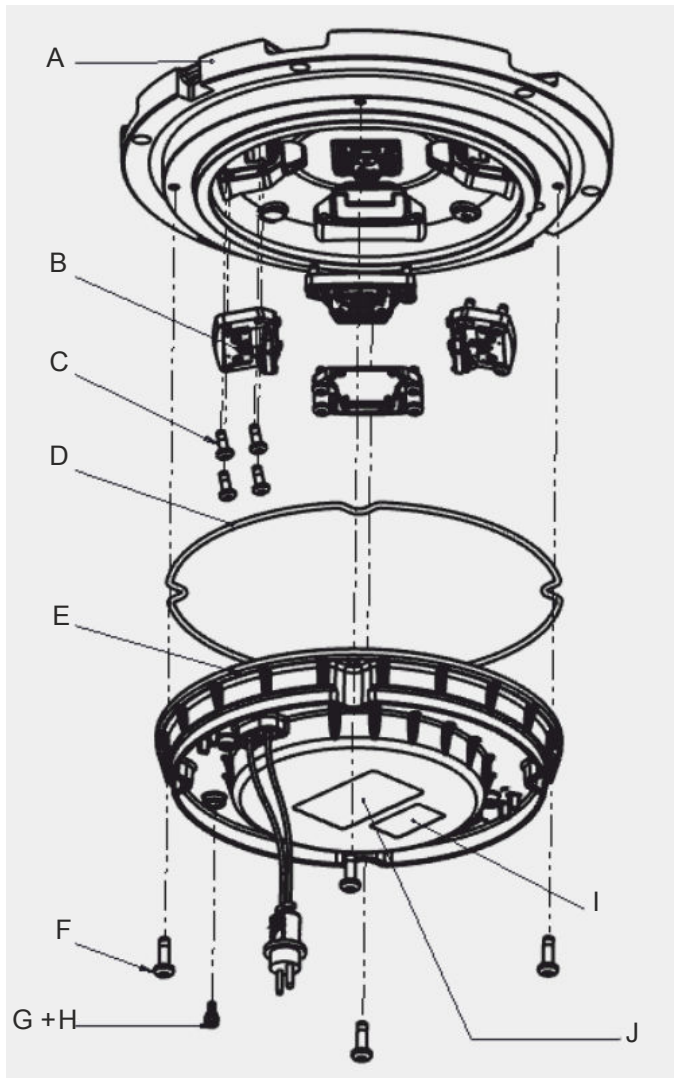

Table 4: Legend Exploded View

Call-out number	Description	Part Number	Quantity
A	Top Cover Assembly	AS000188-005-01	1 pc
B	Light Engine Assembly	AS00143	4 pcs
C	M5 x 8 x 14 PAN A2 6 LOBE LP DIN 7985	MFP M 5PT-714-01	16 pcs
D	O-ring	MS00006-000-01	1 pc
E	Bottom Pan Assembly	AS00024-XXX-01	1 pc
F	M6 x 1 x 20 PAN A2 6 LOBE LP DIN 7985	MFP M 6PT-720-01	4 pcs
G	Pressure Release Screw	MF00090-000-01	1 pc

Table 4: Legend Exploded View (Continued)

Call-out number	Description	Part Number	Quantity
H	O-ring, size 008	MS00001-008-01	1 pcs
I	Power supply label (if applicable)		
J	Product label		

Figure 50: Omnidirectional Light, 4 prisms, 8-inch

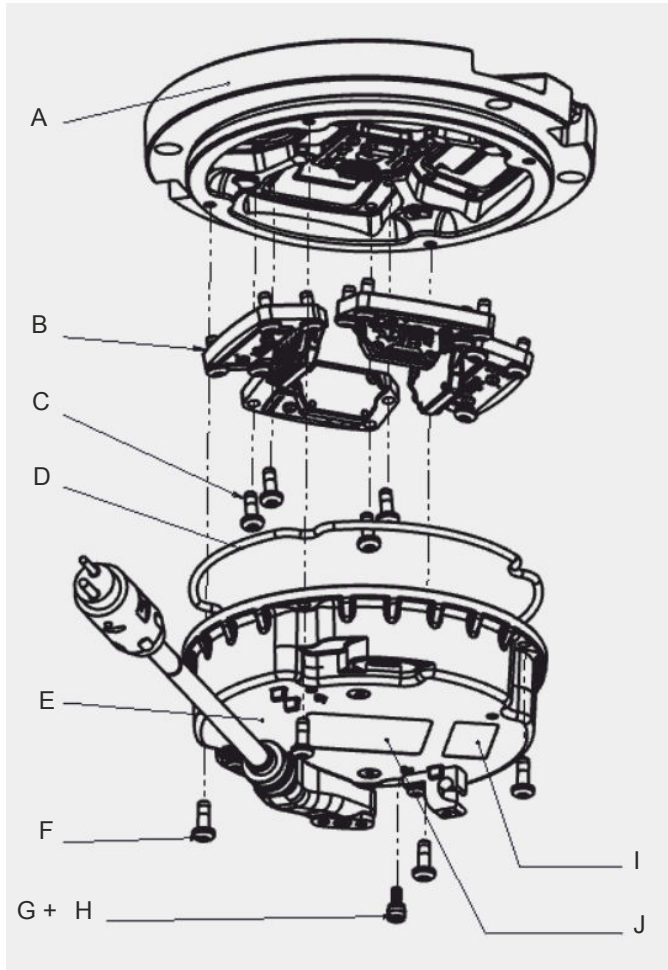

Table 5: Legend Exploded View

Call-out number	Description	Part Number	Quantity
A	Top Cover Assembly	AS00187-005-01	1 pc
B	Light Engine Assembly	AS-00143-XXXX-01	4 pcs
C	M5 x 8 x 14 PAN A2 6 LOBE LP DIN 7985	MFP M 5PT-714-01	16 pcs
D	Bottom Cover Gasket	MS00005-000-01	1 pc
E	Bottom Pan Assembly	AS00021-XXX-01	1 pc
F=C	M5 x 8 x 14 PAN A2 6 LOBE LP DIN 7985	MFP M 5PT-714-01	4 pcs
G	Pressure Release Screw	MF00090-000-01	1 pc

Table 5: Legend Exploded View (Continued)

Call-out number	Description	Part Number	Quantity
H	O-ring, size 008	MS00001-008-01	1 pc
I	Power supply label (if applicable)		
J	Product label		

7.2 Spare Parts - Taxiway Edge

Top cover assembly (including the bottom pan gasket & the bottom pan screws)	Quantity per		spare part code
	fitting		
8-inch	1		SPAS00187-00S
12-inch	1		SPAS00188-00S

Light engine assembly with heater (Including mounting screws)	Quantity per		spare part code
	fitting	spare part	
Blue, EQ (R), TE/L-852T(L)	4	4	SPAS00143-01B0
Blue, non-Monitored (S) or Monitored (M), TE/L-852T(L)	4	4	SPAS00143-01B1
Yellow, EQ (R), TE App.	4	4	SPAS00143-01Y0
Yellow, non-Monitored (S) or Monitored (M), TE App.	4	4	SPAS00143-01Y1
InfraRed & Blue, EQ (R), TE/L-852T(L)	4	4	SPAS00143-I1B0
InfraRed & Blue, non-Monitored (S) or Monitored (M), TE/L-852T(L)	4	4	SPAS00143-I1B1
InfraRed & Yellow, EQ (R), TE App.	4	4	SPAS00143-I1Y0
InfraRed & Yellow, non-Monitored (S) or Monitored (M), TE App.	4	4	SPAS00143-I1Y1

Light engine assembly without heater (including mounting screws)	Quantity per		spare part code
	fitting	spare part	
Blue, TE/L-852T(L)	4	4	SPAS00143-01BN
Yellow, TE App.	4	4	SPAS00143-01YN
InfraRed & Blue, TE/L-852T(L)	4	4	SPAS00143-I1BN
InfraRed & Yellow, TE App.	4	4	SPAS00143-I1YN

Bottom pan assembly for 8" & 12" Taxiway and Runway (including the bottom pan gasket and the bottom pan screws)	Quantity per		spare part code
	fitting	spare part	
non-monitored converter, 1-connector style 6 cord set	1	1	SPAS00021-L13
non-monitored converter, 1-connector 3-pole cord set	1	1	SPAS00021-L1F
non-monitored converter, 1-connector style 1 SJO jacketed cord set	1	1	SPAS00021-L1J
non-monitored converter, 2-connectors style 6 cord sets	1	1	SPAS00021-L23
non-monitored converter, 2-connectors 3-pole cord sets	1	1	SPAS00021-L2F
non-monitored converter, 2-connectors style 1 SJO jacketed cord sets	1	1	SPAS00021-L2J
monitored converter, 1-connector style 6 cord set	1	1	SPAS00021-M13
monitored converter, 1-connector 3-pole cord set	1	1	SPAS00021-M1F
monitored converter, 1-connector style 1 SJO jacketed cord set	1	1	SPAS00021-M1J
monitored converter, 2-connectors style 6 cord sets	1	1	SPAS00021-M23
monitored converter, 2-connectors 3-pole cord sets	1	1	SPAS00021-M2F
monitored converter, 2-connectors style 1 SJO jacketed cord sets	1	1	SPAS00021-M2J
EQ converter, 1-connector style 6 cord set	1	1	SPAS00021-R13
EQ converter, 1-connector 3-pole cord set	1	1	SPAS00021-R1F

Bottom pan assembly for 8" & 12" Taxiway and Runway (including the bottom pan gasket and the bottom pan screws)	Quantity per		spare part code
	fitting	spare part	
EQ converter, 1-connector style 1 SJO jacketed cord set	1	1	SP.AS00021-R1J
Buy American Preference non-monitored converter, 1-connector style 6 cord set	1	1	SP.AS00021-S13
Buy American Preference non-monitored converter, 1-connector style 1 SJO jacketed cord set	1	1	SP.AS00021-S1J

Bottom pan assembly for : 12" runway (including the bottom pan gasket & the bottom pan screws)	Quantity per		spare part code
	fitting	spare part	
non-monitored converter, 1-connector style 6 cord set	1	1	SP.AS00024-L13
non-monitored converter, 1-connector 3-pole cord set	1	1	SP.AS00024-L1F
non-monitored converter, 1-connector style 1 SJO jacketed cord set	1	1	SP.AS00024-L1J
non-monitored converter, 2-connectors style 6 cord sets	1	1	SP.AS00024-L23
non-monitored converter, 2-connectors 3-pole cord sets	1	1	SP.AS00024-L2F
non-monitored converter, 2-connectors style 1 SJO jacketed cord sets	1	1	SP.AS00024-L2J
monitored converter, 1-connector style 6 cord set	1	1	SP.AS00024-M13
monitored converter, 1-connector 3-pole cord set	1	1	SP.AS00024-M1F
monitored converter, 1-connector style 1 SJO jacketed cord set	1	1	SP.AS00024-M1J
monitored converter, 2-connectors style 6 cord sets	1	1	SP.AS00024-M23
monitored converter, 2-connectors 3-pole cord sets	1	1	SP.AS00024-M2F
monitored converter, 2-connectors style 1 SJO jacketed cord sets	1	1	SP.AS00024-M2J
EQ converter, 1-connector style 6 cord set	1	1	SP.AS00024-R13
EQ converter, 1-connector 3-pole cord set	1	1	SP.AS00024-R1F
EQ converter, 1-connector style 1 SJO jacketed cord set	1	1	SP.AS00024-R1J
Buy American Preference non-monitored converter, 1-connector style 6 cord set	1	1	SP.AS00024-S13
Buy American Preference non-monitored converter, 1-connector style 1 SJO jacketed cord set	1	1	SP.AS00024-S1J

Cordsets	Quantity per		spare part code
	fitting	spare part	
Cord Set Kit, L-823 Style 1, 8" Bottom Pan	1 or 2	5	SP.73A0193/1
Cord Set Kit, L-823 Style 1, 12" Bottom Pan	1 or 2	5	SP.73A0194/1
Cord set, L-823 style 6, 8" & 12" bottom pan	1 or 2	5	SP.SGE96253351
Cord set, 3-pole, 8" & 12" bottom pan	1 or 2	5	SP.SGEFR500160
Cable retaining clamp, for use with style 1 cord set	1 or 2	5	SP.MB00003-013-01

Junction Board kit	Quantity per		spare part code
	fitting	spare part	
Junction Board Kit (including mounting screws)	1	4	SP.EP00074-000-01

Prism kit	Quantity per		spare part code
	fitting	spare part	
Prism Kit (including prism, prism gasket, protection plate and mounting screws)	4	4	SP4072.78.021
Prism gasket	Quantity per		spare part code
	fitting	spare part	
Prism Gasket	4	10	SP4072.78.030
Wire harnesses	Quantity per		spare part code
	fitting	spare part	
Wire Harness, power supply to Junction Board for 8" fixtures	1	4	SPEW00070-150-01
Wire Harness, power supply to Junction Board for 12" fixtures	1	4	SPEW00070-300-01
Wire Harness, light engine to Junction Board	4	8	SP6100.50.300
Heater kit (including mounting screws)	Quantity per		spare part code
	fitting	spare part	
Heater Kit for power supply BAP (non-monitoring) and power supply EQ	4	2	SP.EP00077-P00-01
Heater Kit for power supply non-monitoring and power supply with monitoring	4	2	SP.EP00077-P01-01
Interface Top Cover - Bottom Pan	Quantity per		spare part code
	fitting	spare part	
Gasket between Bottom Pan and Top Cover, 8"	1	10	SP.MS00005-000-01
Screws to fix Bottom Pan to top cover 8" & to fix Light Engine	4	100	SP.MFPM5PT-714-01
Gasket between Bottom Pan and Top Cover, 12"	1	10	SP.MS00006-000-01
Screws to fix Bottom Pan to Top Cover 12"	4	100	SP.MFPM6PT-720-01
Ground Lug Kit	Quantity per		spare part code
	fitting	spare part	
Ground Lug Kit	1	5	SP.72A0401
Pressure release screw	Quantity per		spare part code
	fitting	spare part	
Pressure release screw with O-ring	1	5	SP.MF00090-000-01
Fuse	Quantity per		spare part code
	fitting	spare part	
Fuse Resistors (only for fixtures with monitoring (M))	1 or 2	20	6132.00.250

8.0 CABLE LOSS

The cable resistance R (ohms) for 1 conductor is calculated with following formula:

- $R \text{ (ohms)} = \text{resistivity of material (ohm m)} \times \text{length (m)} / \text{cross sectional area (m}^2\text{)}$
- For copper conductors the resistivity is $1.72 \times 10^{-8} \text{ (m}^2\text{)}$

Example; for 1 km 2.5 mm^2 copper conductor, the resistance R is calculated as follows:

$$1.72 \times 10^{-8} \times 1000 / 2.5 \times 10^{-6} \text{ m}^2 = 6.88 \text{ ohms}$$

The loss (Watt) is then $R \times I^2$ or $6.88 \text{ ohms} \times 6.6^2 \text{ A}^2 = 299.69 \text{ W/km}$ or 0.299 W/m .

The loss (Watt) for a secondary cable with 2 conductors is thus $2 \times 0.299 = 0.599$ or 0.6 W/m .

As such we can calculate:

- Secondary cable for a 2.5 mm^2 Cu-wire (2 conductors): 0.6 W/m
- Secondary cable for a 4 mm^2 Cu-wire (2 conductors): 0.4 W/m
- Primary cable for a 6 mm^2 Cu-wire (1 conductor): 0.12 W/m

The cable between the isolation transformer and the lamp adds losses that cannot be ignored when dimensioning the circuits and selecting rating for secondary transformers and regulators.



WARNING

Cable lengths should not exceed 100 meters.

For a secondary cable of e.g., 20 m of 2.5 mm^2 CU-wire, $20 \text{ m} \times 0.6 \text{ W/m} = 12 \text{ W}$ equals the additional loss to be taken into account.

For a primary cable of e.g., 100 m of 6 mm^2 CU-wire, $100 \text{ m} \times 0.12 \text{ W/m} = 12 \text{ W}$ equals the additional loss to be taken into account.

9.0 INTEROPERABILITY

Base installation – O-ring selection and retaining bolts for 12-inch



CAUTION

Use of incorrect combination of gaskets, bolts and nuts can create severe damages to the product installation and create multiple safety risks.

To obtain a safe and watertight installation the O-ring and retaining bolt stated in the document must be used.

You need to know what base the light fixture will be installed in, in order to choose the correct gasket, bolts and nuts.

Failure to follow these cautions can result in equipment damage or aircraft FOD.

Table 6: Interoperability matrix

Base type	Required O-ring	Bolt installation		Stud installation	
		Required dimension	Recommended torque	Required nut	Recommended torque
ADB 8" Eurobase	Blue O-ring (SGE48001263) SGE.SP24521 / 10 pc. SGE.SP24524 / 100 pc.	Metric screw kit 25 mm 1411.20.522	21 Nm + Loctite 2701 or 638	Self-locking nut kit H100 1411.20.430	21 Nm ¹
ADB 8" HPI	Grey O-ring (SGE48001264) SGE.SP24522 / 10 pc. SGE.SP24525 / 100 pc.	Metric screw kit 25 mm 1411.20.522	21 Nm + Loctite 2701 or 638	Self-locking nut kit H100 1411.20.430	21 Nm ¹
Safegate 8" - 135 mm; RELIANCE BASE 8" - 135 mm; Thorn 8" - 100 mm; Thorn 8" - 133 mm; Thorn 8" - MK2 133 mm	Red O-ring (SGE48001298) SGE.SP24523 / 10 pc. SGE.SP24526 / 100 pc.	Metric screw kit 25 mm 1411.20.522	40 Nm + Locking washer (max height 2mm)	Self-locking nut kit H100 1411.20.430	35 Nm
ERNI 8" EE08 - 150mm; ERNI 8" ED08 - 133 mm	Blue O-ring (SGE48001263) SGE.SP24521 / 10 pc. SGE.SP24524 / 100 pc.	Metric screw kit 25 mm 1411.20.522	40 Nm + Locking washer (max height 2mm)	Self-locking nut kit H100 1411.20.430	35 Nm

Table 6: Interoperability matrix (Continued)

Base type	Required O-ring	Bolt installation		Stud installation	
		Required dimension	Recommended torque	Required nut	Recommended torque
IDM 6494 (120mm)	Red O-ring (SGE48001298) SGE.SP24523 / 10 pc. SGE.SP24526 / 100 pc.	Metric screw kit 25 mm 1411.20.522	40 Nm + Locking washer (max height 2mm)	Self-locking nut kit H100 1411.20.430	35 Nm
Adapter ring ADB 8"-12"	Blue O-ring (SGE48001263) SGE.SP24521 / 10 pc. SGE.SP24524 / 100 pc.	Metric screw kit 25 mm 1411.20.522	21 Nm + Loctite 2701 or 638	Self-locking nut kit H100 1411.20.430	21 Nm ¹
Adapter ring SG/Thorn/ID 8"-12"	Red O-ring (SGE48001298) SGE.SP24523 / 10 pc. SGE.SP24526 / 100 pc.	Metric screw kit 25 mm 1411.20.522	40 Nm + Locking washer (max height 2mm)	Self-locking nut kit H100 1411.20.430	35 Nm

Notes

¹ Do not use loctite or washer with self-locking nut.

10.0 POWER TABLE

LED L-852T(L) Taxiway Edge

(TE), 8- and 12-inch **without** Arctic Kit

Fixture type – 1 cord set ¹	Fixture load	Isolation transformer		CCR load
		Wattage	Load	
Taxiway Edge, L-852(T), omnidirectional	9.6 VA	15 W	5.1 VA	14.7 VA

(TE), 8- and 12-inch **with** Arctic Kit

Fixture type – 1 cord set ¹	Fixture load	Isolation transformer		CCR load
		Wattage	Load	
Taxiway Edge, L-852(T), omnidirectional	66 VA	65 W	14 VA	80 VA

Notes

¹ Values provided are for the "S" option non-monitored power only.

(AM), 8- and 12-inch

Fixture type	Fixture load	Isolation transformer			CCR load
		Rating	Loss	Efficiency	
RS -AM (omnidirectional, inset)	35 VA	45 W	7 VA	0.85	45 VA

Note

- EQ fixtures:
 - The isolation transformer must have an additional 8 VA available above the fixture load for communication bandwidth. Size transformer to 65 W on fixture with arctic kit to assure additional 8 VA coverage. Transformers can be safely overloaded by 10 %.
 - Legacy BRITE II or AGLAS 2 systems — Order "M" power supply
- Fail-open fixtures:
 - The maximum rating for the isolation transformer is 200 W
- Additional voltage loss when longer secondary cables are used is not included in above table; these additional losses may result in a larger size isolation transformer requirement and must be factored into the circuit load calculation
- Additional voltage loss in primary cable is not included in above table; this additional loss will result in a higher CCR load and must be factored into the circuit load calculation
- Efficiency of the isolation transformer depends on the manufacturer of the transformer

11.0 SUPPORT

Our experienced engineers are available for support and service at all times, 24 hour/7 days a week. They are part of a dynamic organization making sure the entire ADB SAFEGATE is committed to minimal disturbance for airport operations.

ADB SAFEGATE Support

Live Technical Support - Americas

If at any time you have a question or concern about your product, just contact ADB SAFEGATE's technical service department. Trained in all areas of system issues, troubleshooting, quality control and technical assistance, our highly experienced Technical support specialists are available 24 hours a day, seven days a week to provide assistance over the phone.

ADB SAFEGATE **Americas Technical Service & Support (US & Canada): +1-800-545-4157**

ADB SAFEGATE Americas Technical Service & Support (International): +1-614-861-1304

During regular business hours, you can also Chat with a Service Technician. We look forward to working with you!

Before You Call

When you have an airfield lighting or system control system problem it is our goal to support airfield maintenance staff as quickly as possible. To support this effort we ask that you have the following information ready before calling.

- The *airport code*
- If not with an airport, then company name (prefer customer id number)
- Contact phone number and email address
- Product with part number preferable or product number
- Have you reviewed the product's manual and troubleshooting guide
- Do you have a *True RMS* meter available (and any other necessary tools)
- Be located with the product ready to troubleshoot

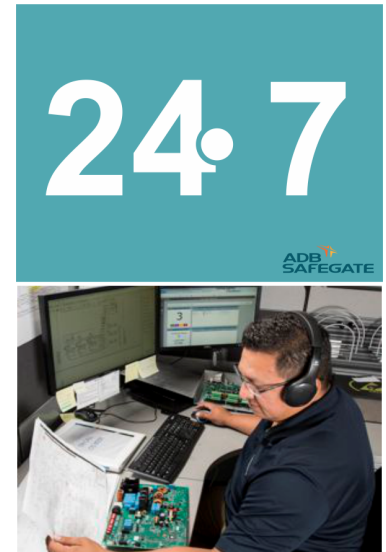

Note

For more information, see www.adbsafegate.com, or contact ADB SAFEGATE Support via email at support@adbsafegate.com or

Brussels: +32 2 722 17 11

Rest of Europe: +46 (0) 40 699 17 40

Americas: +1 614 861 1304. Press 3 for technical service or press 4 for sales support.

China: +86 (10) 8476 0106

11.1 ADB SAFEGATE Website

The ADB SAFEGATE website, www.adbsafegate.com, offers information regarding our airport solutions, products, company, news, links, downloads, references, contacts and more.

11.2 Recycling

11.2.1 Local Authority Recycling

The disposal of ADB SAFEGATE products is to be made at an applicable collection point for the recycling of electrical and electronic equipment. The correct disposal of equipment prevents any potential negative consequences for the environment and human health, which could otherwise be caused by inappropriate waste handling. The recycling of materials helps to conserve natural resources. For more detailed information about recycling of products, contact your local authority city office.

11.2.2 ADB SAFEGATE Recycling

ADB SAFEGATE is fully committed to environmentally-conscious manufacturing with strict monitoring of our own processes as well as supplier components and sub-contractor operations. ADB SAFEGATE offers a recycling program for our products to all customers worldwide, whether or not the products were sold within the EU.

ADB SAFEGATE products and/or specific electrical and electronic component parts which are fully removed/separated from any customer equipment and returned will be accepted for our recycling program.

All items returned must be clearly labeled as follows:

- For *ROHS/WEEE* Recycling
- Sender contact information (Name, Business Address, Phone number).
- Main Unit Serial Number.

ADB SAFEGATE will continue to monitor and update according for any future requirements for *EU directives* as and when *EU member states* implement new *regulations* and or *amendments*. It is our aim to maintain our *compliance plan* and assist our customers.

Company Addresses

ADB SAFEGATE, Belgium	ADB SAFEGATE BV Leuvensesteenweg 585, B-1930 Zaventem Belgium
Contact: Tel.: +32 2 722 17 11 Fax: +32 2 722 17 64	Email: marketing@adbsafegate.com Internet: www.adbsafegate.com
ADB SAFEGATE, Americas	ADB SAFEGATE Americas LLC 977 Gahanna Parkway, Columbus, OH 43230 USA
Contact: Tel.: +1 (614) 861 1304 Fax: +1 (614) 864 2069	Email: sales.us@adbsafegate.com Internet: www.adbsafegate.com
ADB SAFEGATE, Sweden	ADB SAFEGATE Sweden AB Djurhagegatan 19 SE-213 76 Malmö Sweden
Contact: Tel.: +46 (0)40 699 17 00 Fax: +46 (0)40 699 17 30	Email: marketing@adbsafegate.com Internet: www.adbsafegate.com
ADB SAFEGATE, China	ADB SAFEGATE Airfield Technologies Ltd. China Unit 603, D Block, CAMIC International Convention Center, No 3, Hua Jia Di East road, ChaoYang district, Beijing 100102 P.R. China
Contact: Tel.: +86 (10) 8476 0106 Fax: +86 (10) 8476 0090	Email: china@safegate.com Internet: www.adbsafegate.com
ADB SAFEGATE, Germany	ADB SAFEGATE Germany GmbH Konrad-Zuse-Ring 6, D-68163 Mannheim Germany
Contact: Tel.: +49 (621) 87 55 76-0 Fax: +49 (621) 87 55 76-55	Email: marketing@adbsafegate.com Internet: www.adbsafegate.com



Powering Your Airport Performance from Approach to Departure

adbsafegate.com

Copyright © ADB SAFEGATE, all rights reserved

